



H2020 5G-TRANSFORMER Project
Grant No. 761536

Definition of vertical testbeds and initial integration plans

Abstract

This deliverable presents the initial plan to design, implement and deploy the Proof-of-Concepts of the use cases defined by the verticals involved in the 5G-TRANSFORMER project. At the same time, this document also includes an initial plan to deploy a configurable testbed integrating all components developed in other work packages of the project over the interconnected trial sites that will be described here. In order to do this, we start by analyzing the technologies and functionalities available on these four sites provided by the partners of the project. We then study the network parameters like throughput and round-trip time obtained between all links connecting the four sites through the Internet, in order to verify the viability to connect them. This document reports the Proof-of-Concepts per use case that will be performed in the project, highlighting the technologies and functional requirements that are necessary. These Proof-of-Concepts are aligned with the implementation plans provided by the correspondent work packages of the project. After analyzing all this information, the document concludes with an initial planning of the overall testbed: how to connect all sites, the technologies to access the integrated testbed, the possibility to provide layer 2 connectivity between sites and the tools to manage this testbed.

Document properties

Document number	D5.1
Document title	Definition of vertical testbeds and initial integration plans
Document responsible	Jaime Garcia-Reinoso (UC3M)
Document editor	Jaime Garcia-Reinoso (UC3M)
Editorial team	Jaime Garcia-Reinoso (UC3M), Juan Brenes (ATOS), Cao-Thanh Phan (BCOM), Marina Giordanino (CRF)
Target dissemination level	Public
Status of the document	Final
Version	1.0

Production properties

Reviewers	Andrés García-Saavedra (NEC), Charles Turyagyenda (IDCC), Jaime Garcia-Reinoso (UC3M), Carlos J. Bernardos (UC3M), Juan Brenes (ATOS)
------------------	---

Disclaimer

This document has been produced in the context of the 5G-Transformer Project. The research leading to these results has received funding from the European Community's H2020 Programme under grant agreement N° H2020-761536.

All information in this document is provided "as is" and no guarantee or warranty is given that the information is fit for any particular purpose. The user thereof uses the information at its sole risk and liability.

For the avoidance of all doubts, the European Commission has no liability in respect of this document, which is merely representing the authors view.

Table of Contents

List of Contributors.....	5
List of Figures.....	6
List of Tables.....	7
List of Acronyms.....	8
Executive Summary and Key Contributions.....	10
1 Introduction.....	12
2 5G-TRANSFORMER architecture.....	14
2.1 Vertical Slicer (5GT-VS).....	15
2.2 Service Orchestrator (5GT-SO).....	16
2.3 Mobile Transport and Computing Platform (5GT-MTP).....	17
2.4 Monitoring Architecture.....	18
3 Testbeds description.....	20
3.1 5TONIC.....	20
3.2 CTTC.....	22
3.3 EURECOM.....	26
3.4 ARNO.....	28
3.5 Integrated testbed.....	32
4 Inter-testbeds measurements.....	36
4.1 Methodology.....	36
4.2 Performance Analysis.....	37
4.2.1 Inter-sites latency.....	37
4.2.2 Inter-site throughput.....	38
4.2.3 Deployment Options.....	40
5 Initial planning of the Proof of Concepts.....	43
5.1 Automotive PoC.....	43
5.1.1 Description.....	43
5.1.2 Initial planning of the PoC.....	46
5.2 Entertainment PoC.....	48
5.2.1 Description.....	48
5.2.2 Initial planning of the PoC.....	49
5.3 E-Health PoC.....	51
5.3.1 Description.....	51
5.3.2 Initial planning of the PoCs.....	52
5.4 E-industry PoC.....	53

5.4.1	Description	53
5.4.2	Initial planning of the PoC	55
5.5	MNO/MVNO: 5G Network as a Service use case.....	55
5.5.1	Description	55
5.5.2	Initial planning of the PoC	56
5.6	PoCs Summary	57
5.6.1	Requirements	57
5.6.2	Platform integration and PoC scheduling	59
6	Initial integration plan.....	62
6.1.1	Data plane interconnection	64
6.1.2	Management of the integrated testbed.....	65
7	Conclusions	67
8	References	68
9	Annex I: List with the technologies required in 5G.....	70
10	Annex II: Functional requirements for the 5G-TRANSFORMER platform	72
11	Annex III: C-plane latency analysis.....	74

List of Contributors

Partner Short Name	Contributors
UC3M	Jaime García-Reinoso, Antonio Pastor, Antonio de la Oliva, Luca Cominardi
TEI	Paola Iovanna, Teresa Pepe
ATOS	Juan Brenes, Arturo Zurita, Antonio Gomez
ORANGE	Philippe Bertin
BCOM	Cao-Thanh Phan, Farouk Messaoudi
NXW	Giada Landi
CRF	Marina Giordanino
CTTC	Iñaki Pascual, Jordi Baranda, Ricardo Martínez, Josep Mangues, Ramon Casellas, Manuel Requena, Francisco Javier Vilchez
POLITO	Carla-Fabiana Chiasserini
EURECOM	Adlen Ksentini, Pantelis Frangoudis
SSSA	Luca Valcarenghi, Koteswararao Kondepu

List of Figures

Figure 1: 5G-Transformer system architecture	15
Figure 2: Hierarchy of monitoring services in 5G-TRANSFORMER architecture	19
Figure 3: 5TONIC infrastructure	20
Figure 4: CTTC testbed infrastructure	23
Figure 5: EURECOM's CRAN testbed	26
Figure 6: EURECOM'S MEC TESTBED	27
Figure 7: ARNO TESTBED	29
Figure 8: ARNO testbed 5G access segment.....	30
Figure 9: ARNO Metro aggregation (OvS switches, HPE Switches, Routers from left to right)	30
Figure 10: ARNO testbed core network (from left to right: Ericsson SPO-1410, 100G cards, WSS).....	31
Figure 11: ARNO data centre segment (from left to right: data center, openstack and ONOS, OpenStack + ONOS + InstantContiki).....	31
Figure 12: Representative view of the ping and iperf tests	36
Figure 13: Average RTT boxplots between the trial sites without background traffic. The boxplots include the 10th, 25th, median, 75th, and 90th percentiles of these RTT	38
Figure 14: Maximum RTT boxplots between the trial sites without background traffic. The boxplots include the 10th, 25th, median, 75th, and 90th percentiles of these RTT	38
Figure 15: Uplink and Downlink throughput between trial sites (tests run during four days).....	39
Figure 16: Representation of the measurement data in the form of a boxplot for the uplink and downlink directions.....	40
Figure 17: An example of a multi-site deployment of a service using mobile connectivity: sites A, B, C and D can be equal in twos	41
Figure 18: Possible distributed deployment of 5G-Transformer components across many sites: A, B, C, D and E can be equal two by two	42
Figure 19: ICA design	45
Figure 20: OLE and UHD Design	49
Figure 21: E-Health Framework	52
Figure 22: Virtualization of control in the cloud: latency requirements	54
Figure 23: 5G-TRANSFORMER integrated testbed. Initial plan	63
Figure 24: Data plane with layer 2 and layer 3 networks	65

List of Tables

Table 1: 5TONIC Technologies.....	22
Table 2: CTTC TECHNOLOGIES	25
Table 3: EURECOM Technologies.....	28
Table 4: ARNO Technologies	32
Table 5: Technologies available for 5G-TRANSFORMER.....	33
Table 6: Automotive PoCs	46
Table 7: OLE and UHD PoCs.....	50
Table 8: e-Health PoCs.....	52
Table 9: E-industry PoCs	55
Table 10: MNO/MVNO PoCs	56
Table 11: Technology requirements per use case.....	57
Table 12: Technologies classified in 4 main categories.....	58
Table 13: Functional requirements per use case.....	59
Table 14: PoCs and Demos scheduling	60
Table 15: 5G-TRANSFORMER Functional requirements.....	72
Table 16: C-PLANE LATENCY ANALYSIS FROM 3GPP PERSPECTIVE.....	74

List of Acronyms

Acronym	Description
5GT-MTP	5G-TRANSFORMER Mobile Transport and Computing Platform
5GT-SO	5G-TRANSFORMER Service Orchestrator
5GT-VS	5G-TRANSFORMER Vertical Slicer
BBU	Baseband Unit
CAM	Cooperative Awareness Messages
CDN	Content Delivery Network
CIM	Cooperative Information Manager
CR	Cloud Robotics
CSMF	Communication Service Management Function
DC	Data Center
DENM	Decentralized Environmental Notification Message
DVR	Digital Video Recorder
EPC	Evolved Packet Core
EPS	Evolved Packet System
FPGA	Field-Programmable Gate Array
ICA	Intersection Collision Avoidance
IoT	Internet of Things
LTE	Long-Term Evolution
GMPLS	Generalized Multi-Protocol Label Switching
MANO	Management and Orchestration
MEC	Multi-access Edge Computing
MEP	MEC Platform
NFV	Network Function Virtualization
NFV-NS	Network Service
NFV-NSO	Network Service Orchestrator
NFVI	Network functions virtualisation infrastructure
NFVlaaS	NFVI as a Service
NFVO-RO	Resource Orchestrator
NGFI	New Generation Fronthaul Interface
NSD	Network Service Descriptor
NSI	Network Slice Instance
NSMF	Network Slice Management Function
NSSMF	Network Slice Subnet Management Function
OAI	OpenAirInterface
OBU	On Board Unit
OFDM	Orthogonal Frequency Division Multiplexing
OLE	On-site Live Experience
OSM	Open Source MANO
OSS/BSS	Operating and Business Support Systems
OVS	OpenVSwitch
PNF	Physical Network Function
PoC	Proof-of-Concept
RNIS	Radio Network Information Service
RRH	Remote Radio Header
RSU	Road Side Unit
SDR	Software Defined Radio
TD	Technology Domain
TSP	5G-TRANSFORMER Service Provider

UHD	Ultra High Definition
USRP	Universal Software Radio Peripheral
VA	Virtual Application
vEPC	Virtual EPC
VIM	Virtual Infrastructure Manager
VNF	Virtualised Network Function
VNFM	Virtual Network Functions Manager
VPN	Virtual Private Network
VSD	Vertical Service Descriptor
VSI	Vertical Service Instance
VXLAN	Virtual eXtensible Local Area Network
WIM	WAN Infrastructure Manager

Executive Summary and Key Contributions

One of the main goals of the 5GT-TRANSFORMER project is to demonstrate and validate the technology components designed and developed in the project. In order to accomplish this objective, the aim of WP5 is to integrate all components provided by WP2, WP3 and WP4 and include all of them in a common testbed where the four different trial sites can be interconnected in different configurations depending on the requirements. After this configuration is complete, and the trial sites interconnected in the requested topology, WP5 has to conduct tests of the different use cases defined in WP1 by means of Proof-of-Concepts (PoCs).

The scope of this deliverable is to start planning the work that will be done in WP5. This planning will be extended in the next deliverable when the 5G-TRANSFORMER is more stable and when the different use cases are totally defined. The key contributions and the associated outcomes of this deliverable are the following:

- A list with the main technologies required in 5G networks is available in Annex I.
- A list with the functionalities provided by the components that will be developed in the project, available in Annex II.
- Trial sites description, including available technologies and services that the partners of the 5G-TRANSFORMER provide to the project.
- Inter-testbeds measurements to analyse the performance we can expect from the integrated testbed in terms of throughput and delay between the different trial sites.
- An analysis on how the individual trial sites can be interconnected through the Internet, both at the data and control plane.
- An initial planning of the Proof-of-Concepts (PoCs) per use case, their description, the technologies and functional requirements demanded by these PoCs.
- A roadmap to deploy such PoCs and the correspondent use cases, which will be shown and tested after these PoCs are integrated together. This roadmap is aligned with the initial implementation plans provided by the correspondent work packages, which will provide the 5G-TRANSFORMER infrastructure that will be used to deploy the use cases defined by the verticals of the project.
- An initial integration plan to provide a flexible and configurable testbed connecting the required trial sites, depending on the necessities of the PoCs defined in this document.

The inter-testbeds measurements performed show that it is feasible to interconnect the different trial sites through the Internet, with a reasonable expected performance, in terms of throughput and round-trip time. Some connections have better performance than others, and even between the same two points the uplink is different than the downlink, so these results will be taken into account to decide the best topology to interconnect these trial sites.

Although most of the technologies and services required by the PoCs are provided by the trial sites, we have detected that not all of them are available. We have to coordinate with other work packages to tackle this important issue. Regarding the functionalities provided by the functional blocks of the project, all of them will be tested in at least two use cases, guaranteeing the proper validation of such functionalities.

Finally, one important result of this deliverable is the initial proposal to deploy the integrated testbed among all trial sites. The point-to-point connections will be based on layer VPNs, as this facility is available in all trial sites. Both the data and control plane between sites will be transported over VPNs. If necessary, it would be possible to use VXLANs to provide layer 2 connectivity between the required end points.

1 Introduction

One of the main goals of WP5 in the 5G-TRANSFORMER project is to integrate the technology components developed in WP2, WP3 and WP4. This integrated platform will be used to experimentally validate that all these components together can satisfy the stringent requirements imposed by the verticals. This will be done by means of executing the proof-of-concepts defined by the vertical partners of the project. These proof-of-concepts (PoCs) will be executed on top of an integrated testbed composed of several elements provided by the partners in four sites: 5TONIC in Madrid, CTTC in Barcelona, EURECOM in Sophia Antipolis and ARNO in Pisa. Every site provides particular components¹ that may not always be available at other sites, so the integration of such sites in one single testbed enables the design of complex and realistic trials, e.g., via federation.

On the one hand, in order to fulfil the main objectives of WP5, task 5.1 (T5.1) is in charge of defining and setting up the aforementioned integrated testbed. On the other hand, task 5.2 (T5.2) will integrate the components developed in WP2, WP3 and WP4, deploying all PoCs once the integrated testbed is available. This document, deliverable D5.1, presents a plan to integrate the four sites and an initial definition of all PoCs that will be deployed and tested during the project.

This deliverable starts presenting an overall view of the 5G-TRANSFORMER architecture in Section 2. Section 3 introduces the four sites that will form the integrated testbed. This section summarizes the main technologies available in each site, how they are internally interconnected, and the protocols/interfaces to access to such sites from the outside. With the aim of presenting a common structure in all sites, we have elaborated a list (available in Annex I) with all categories of technologies necessary in a 5G testbed. After introducing each site, this section finalizes summarizing all pieces of technology that will be available in the integrated testbed. Because all these four testbeds will be interconnected using the Internet, we have conducted several tests to collect network parameters between each pair of sites, namely end-to-end throughput and round-trip-time (RTT). Section 4 shows these results, analyzing the performance and providing some insights that will be used in next sections to design the integrated testbed.

Section 5 presents the initial planning of the Proof-of-Concepts. In order to better analyze the requirements of the vertical partners of the project, this section starts with an initial planning of the proof-of-concepts that will be implemented and tested on the integrated testbed. WP1 has selected the use cases that will be deployed in the project, and this information is available in deliverable D1.2 [2]. These use cases come from five categories of verticals: automotive, entertainment, E-Health, eIndustry and mobile system operators. Section 5 shows an initial planning of the different proof-of-concepts for each use case, the technologies required by each proof-of-concept and the scheduling. Each proof-of-concept includes its functional requirements that should be available in the integrated testbed. The list of all functional requirements provided by the 5G-TRANSFORMER functional blocks has been extracted from deliverables D2.1 [6], D3.1 [8] and D4.1 [7] and its available in Annex II.

¹ A complete list of all technology components provided by each site to the project is listed later in this document.

Section 6 proposes an initial planning for the testbed integration, following the conclusions presented in the previous sections.

Finally, Section 7 concludes with some recommendations to integrate the components of the project and to deploy the integrated testbed.

2 5G-TRANSFORMER architecture

In order to ease the reading of this document, this section starts with a summary² of the system architecture described in D1.2 [2]. We use the concepts detailed in this section to describe the initial plan for the testbed integration described in sections 5 and 6. In Annex II we describe a set of functional requirements identified by the vertical industries for the 5G-TRANSFORMER platform implementing the architecture introduced here. We use these functional requirements to establish the initial planning of the PoCs (as detailed in section 5).

The 5G-TRANSFORMER project explores how the network can better serve the needs of 5G-TRANSFORMER customers (i.e., vertical industries and M(V)NOs) by offering the abstraction, flexibility, and dynamic management capabilities they require. In terms of notation, it is important to differentiate between (vertical) service, i.e., that is requested by the customer of the 5G-TRANSFORMER system, from the underlying network service deployed to fulfill the requirements of the vertical. An example of the former is a car manufacturer requesting the deployment of an automotive intersection collision avoidance service. The latter will be deployed in the form of an NFV network service, in general.

The key architectural concept to support such adaptation to the needs of verticals and M(V)NOs is network slicing. The term network slice aligns network functionality to business needs [3], since it allows customers to request not just functions, but also business objectives (e.g., quality of service, security, etc.), as a sort of intent. The scope of a slice may be a single customer facing service (using TM Forum terminology [4]) or a group of such services. The system will also allow infrastructure providers to share the 5G mobile transport and computing infrastructure efficiently among verticals and M(V)NOs, hence enhancing 5G-TRANSFORMER provider network usage efficiency. In terms of deployment, network slices can be implemented by means of ETSI NFV network services.

The architecture is conceived to support multiple combinations of stakeholders by introducing open Application Programming Interfaces (API) among components [5]. Through these APIs, the system hides unnecessary details from the verticals, allowing them to focus on the definition of the services and the required Service Level Agreements (SLAs). As for interfaces, particularly relevant for the goals of the project are east-westbound interfaces, which enable service and resource federation across different administrative domains, allowing 5G-TRANSFORMER service providers to enhance their service offerings to their customers by peering with other providers.

We envision a system comprised of three major components: vertical slicer (5GT-VS), service orchestrator (5GT-SO) and mobile transport and computing platform (5GT-MTP), see Figure 1. The 5GT-VS is the entry point for the vertical requesting a service, and it handles the association of these services with slices as well as network slice management. The 5GT-SO is responsible for the end-to-end orchestration of services across multiple domains and for aggregating local and federated (i.e., from peer domains) resources and services and exposing them to the 5GT-VS in a unified way.

² This is text common to [6], [7], [8], [2] and this document.

Finally, the 5GT-MTP provides and manages the virtual and physical IT and network resources on which service components are eventually deployed. It also decides on the abstraction level offered to the 5GT-SO.

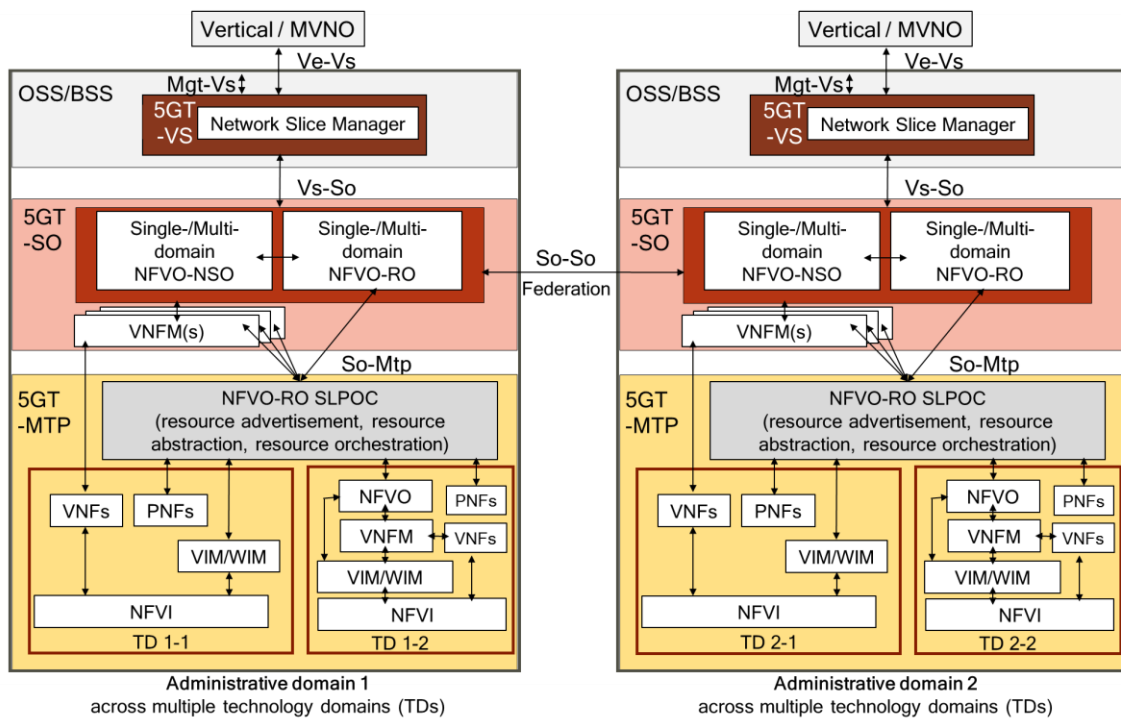

FIGURE 1: 5G-TRANSFORMER SYSTEM ARCHITECTURE

2.1 Vertical Slicer (5GT-VS)

The 5GT-VS is the common entry point for all verticals into the 5G-TRANSFORMER system. It is part of the operating and business support systems (OSS/BSS) of the 5G-TRANSFORMER service provider (TSP) [5]. Vertical services are offered through a high-level interface at the 5GT-VS northbound that is designed to allow verticals to focus on the service logic and requirements, without caring on how they are eventually deployed at the resource level. This latter issue would be up to 5GT-SO. Therefore, vertical services will use those services offered by the TSP. In fact, the 5GT-VS offers a catalogue of vertical service blueprints, based on which the vertical service requests are generated by the vertical. The role of the 5GT-VS is to trigger the actions allowing the 5G-TRANSFORMER system to fulfill the requirements of a given incoming service request. After the appropriate translation between service requirements and slice-related requirements by the VSD/NSD Translator and Arbitrator, corresponding to the Communication Service Management Function (CSMF), as defined in [9], a decision is taken on whether the service is included in an already existing slice or a new one is created.

The vertical slicer is the component of the system that is conscious of the business needs of the vertical, their SLA requirements, and how they are satisfied by mapping them to given slices. Intra-vertical arbitration is also part of the vertical slicer, by which intra-vertical contention is resolved to prioritize those services that are more critical, according to the agreed SLA.

The VSI/NSI Coordinator and LC Manager is the core component of the 5GT-VS. It contains functionality that can be mapped to that of the Network Slice Management Function (NSMF) and Network Slice Subnet Management Function (NSSMF), as defined in [9]. More specifically, the NSMF is in charge of lifecycle management of network slice instances. All possible combinations between vertical services and network slices exist; that is, a network slice can be shared by different vertical services, but a given vertical service may be mapped to multiple network slices as well. In turn, network slices may be composed by network slice subnets, which may offer part of the functionality required by a given network slice. And network slice subnets may be shared by multiple network slices.

The final result of all this process is a request sent by the 5GT-VS towards the 5GT-SO to create or update the NFV network services (NFV-NS) that implement the slices.

In summary, through this process, the 5GT-VS maps vertical service descriptions and instantiation parameters at the vertical application level into an NFV-NS (existing or new) implementing the network slice. In turn, such NFV-NS will be updated or created through a network service descriptor (NSD), which is a service graph composed of a set of virtual (network) functions (V(N)F) chained with each other, and the corresponding fine-grained instantiation parameters (e.g., deployment flavour) that are sent to the 5GT-SO. Given the operations carried out through it, the VS-SO interface takes ETSI NFV IFA013 [10] as basis.

2.2 Service Orchestrator (5GT-SO)

The NFV-NS from the 5GT-VS is received by the 5GT-SO through the VS-SO interface. The main duty of the 5GT-SO [11] is to provide an end-to-end orchestration of the NFV-NS across multiple administrative domains by interacting with the local 5GT-MTP (So-Mtp reference point) and with the 5GT-SOs of other administrative domains (So-So reference point). If needed (e.g., not enough local resources), the 5GT-SO interacts with 5GT-SOs of other administrative domains (federation) to take decisions on the end-to-end (de)composition of virtual services and their most suitable execution environment. Even if a service is deployed across several administrative domains, e.g., if roaming is required, a vertical still uses one 5GT-VS to access the system, and so, the 5GT-SO hides this federation from the 5GT-VS, and thus, the verticals.

The 5GT-SO embeds the network service orchestrator (NFV-NSO) and the resource orchestrator (NFVO-RO) with functionalities equivalent to those of a regular NFV orchestrator and it may be used for single and multi-domains as stated in ETSI guidelines [12].

Since the network slices handled at the 5GT-VS will in general serve complex end-to-end services, in the general case, the corresponding network service will be a composition of nested NFV-NSs. The lifecycle management of this complex NFV-NS is the role of the NFV-NSO.

In case a network service is requested that must be distributed across multiple domains, the 5GT-SO receiving the request becomes the parent NFV-NSO and sends ETSI NFV IFA013 [10] requests for each of the constituent NFV-NSs to other NFV-NSOs. Therefore, a hierarchy of NFVO-NSOs is established. The child NFVO-NSOs may belong to the same 5GT-SO that received the request from the 5GT-VS or to a peer 5GT-SO, which, in turn, may establish an additional hierarchy, which is

transparent for the parent NFVO-NSO. The child NFVO-NSO belonging to the same 5GT-SO would be in charge of the lifecycle management of the constituent service that is eventually deployed over the local 5GT-MTP, i.e., the 5G-MTP with which the 5GT-SO has a direct relationship through the SO-MTP interface. When a child NFVO-NSO belongs to a different domain, there is service federation.

Eventually, a resource-related request is generated towards the underlying NFVO-RO to assign virtual resources towards the deployment of the (constituent) NFV-NS. The NFVO-RO functionality of the 5GT-SO handles resources coming from the local 5GT-MTP (real or abstracted) and from the 5GT-SOs of other administrative domains (abstracted). The NFVO-RO will decide on the placement of the Virtual Network Functions (VNF) of the NFV-NS based on the information available in the NFVI resources repository and the NFV instances repository. Most likely, the information available in these repositories will be more detailed when coming from the local 5GT-MTP than from a federated domain.

As for the NFV infrastructure as a service (NFVlaaS) use case, the 5GT-VS will request the 5GT-SO for a set of virtual resources, as opposed to a complete E2E NFV-NS as before. Therefore, this request is directly handled by the NFVO-RO, which is in charge of allocating resources either from the local 5GT-MTP or from a peer 5GT-SO. The latter option corresponds to resource federation. In this case, the request from the local NFVO-RO will reach the NFVO-RO of the peering domain. In all cases, the interaction between NFVO-ROs is based on ETSI NFV IFA005 [13]. This also includes the interface with the 5GT-MTP, where an additional NFVO-RO lower in the hierarchy is embedded, as explained below.

Notice that the NFVI resources handled by the NFVO of the 5GT-SO based on which decisions are taken will have a higher or lower abstraction level depending on the policies applied in this respect by the 5GT-MTP and the peering 5GT-SO. In general, the NFVO-RO of the local 5GT-SO will take coarse-grained decisions and the 5GT-MTP and peer 5GT-SO will take finer-grained ones, since they are closer to the actual resources.

The 5GT-SO also embeds the Virtual Network Function Managers (VNFM) to manage the lifecycle of the VNFs composing the NFV_NS. ETSI NFV IFA006-based interfaces [14] will be used to allow the VNFM interacting with the NFVO-RO Single Logical Point of Contact (SLPOC) entity in the 5GT-MTP, as well as peer SOs for resource allocation requests involving the VNFs under its control. For managing the VNF instances, ETSI NFV IFA008-based interfaces [15] will be used to allow the VNFM to directly configure the VNF instances running in the 5GT-MTP.

2.3 Mobile Transport and Computing Platform (5GT-MTP)

The 5GT-MTP [16] is responsible for orchestration of resources and the instantiation of V(N)Fs over the infrastructure under its control, as well as managing the underlying physical mobile transport network, computing and storage infrastructure. In general, there will be multiple technology domains (TD) inside an 5GT-MTP (e.g., data centres, mobile network, wide area network). The 5GT-MTP NFVO-RO acts as end-to-end resource orchestrator across the various technology domains of the 5GT-MTP. The computing and storage infrastructure may be deployed in central data centres as well as distributed ones placed closer to the network edge, as in MEC [17]. Therefore, the

5GT-MTP is in charge of managing the virtual resources on top of which the NFV-NSs are deployed.

In terms of resource orchestration, the NFVO-RO acts as a single entry point, i.e., the single logical point of contact (SLPOC) in ETSI NFV IFA028 [21] terminology, for any resource allocation request coming from the 5GT-SO. The SO-MTP interface is based on ETSI NFV IFA005 [13] and ETSI NFV IFA006 [14]. The former allows the NFVO-RO of the 5GT-SO to request resource allocations to the NFVO-RO of the 5GT-MTP, whilst the latter allows the VNFM of the 5GT-SO to request resource allocations for the VNF under its control.

In terms of managing VNF instances, the SO-MTP interface also consists of ETSI NFV IFA008-based interfaces [15] to allow the VNFM of the 5GT-SO to directly configure the VNF instances running in the 5GT-MTP.

Depending on the use case, the 5GT-MTP may offer different levels of resource abstraction to the 5GT-SO. However, the 5GT-MTP NFVO-RO has full visibility of the resources under the control of the Virtual Infrastructure Managers (VIM) managing each technology domain, since they belong to the same administrative domain. ETSI NFV IFA005-based interfaces [13] are deployed between the 5GT-MTP NFVO-RO and the 5GT-MTP VIMs. Therefore, when receiving a resource allocation request from the 5GT-SO, the 5GT-MTP NFVO-RO generates the corresponding request to the relevant entities (e.g., VIM or WAN Infrastructure Manager (WIM)), each of them providing part of the virtual resources needed to deploy the VNFs and/or configure the relevant parameters of the PNFs that form the NFV-NS. As a special case, a resource request may be translated into an ETSI NFV IFA013-based NFV-NS request [10] towards a mobile network technology domain [24]. This option is offered to hide the complexity of the mobile network to the rest of the system whilst keeping the required flexibility inside the mobile domain (e.g., to decide on the most appropriate functional split). Therefore, a full ETSI MANO stack is represented in technology domain 1-2 (see Figure 1) even if the focus of the 5GT-MTP is handling virtual resources and not NFV-NSs. In any case, this NFV-NS is hidden to the 5GT-SO, since it is abstracted as a virtual link.

2.4 Monitoring Architecture

In the 5G-TRANSFORMER framework, each architectural component (i.e. 5GT-VS, 5GT-SO, 5GT-MTP) includes a monitoring service able to provide performance metrics and failure reports targeting the logical entities managed by each component. Following this approach, the 5GT-MTP monitoring service will produce monitoring data about the local physical and virtual resources, the 5GT-SO monitoring service will produce monitoring data about the managed VNFs and NFV network services, while the 5GT-VS monitoring service will produce monitoring data about network slices and vertical services. This hierarchy of monitoring services is shown in Figure 2, where the arrows indicates a consumer-provider interaction. In particular, the 5GT-SO monitoring service can be a consumer of the monitoring service provided by the underlying 5GT-MTP or by a federated 5GT-SO, while the 5GT-VS can be a consumer of the monitoring service provided by the local 5GT-SO.

The monitoring data generated at each layer can be used to feed internal decisions within each architectural component or to serve external consumers of monitoring data. For example, the 5GT-SO monitoring service can elaborate performance metrics about

an NFV network service, and these metrics can be used by the 5GT-SO to take scaling decisions for the involved VNFs. On the other hand, the performance metrics computed at the 5GT-SO monitoring service can be provided to the 5GT-VS monitoring service for further elaboration. When metrics and alerts are exchanged between two monitoring services, the level of visibility and disclosure of monitoring information should be regulated based on authorization policies and business agreements, in particular when monitoring data that belongs to different administrative entities. This may be the case, for example, between the 5GT-MTP and the 5GT-SO monitoring services when they are handled by different actors or between the monitoring services of federated 5GT-SOs.

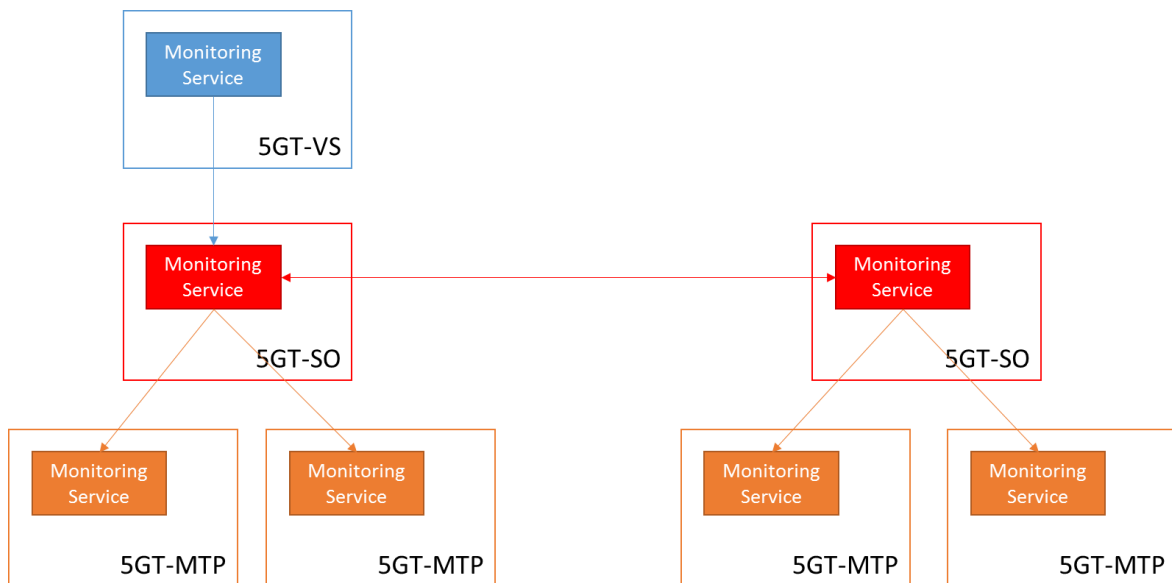

FIGURE 2: HIERARCHY OF MONITORING SERVICES IN 5G-TRANSFORMER ARCHITECTURE

It is important to highlight that the 5G-TRANSFORMER architecture does not impose any constraint on the monitoring platform implementation, but defines just the expected behavior of the service and the external APIs that each monitoring platform should expose to the consumers of its monitoring data. This means that each actor may implement its own specific monitoring platform and in case of overlapping roles, like in the 5GT-VS and 5GT-SO case where they are owned and managed by the same administrative entity, a single monitoring platform may be deployed for both of them.

3 Testbeds description

This section presents an overview of the four testbeds providing their resources to the 5G-TRANSFORMER project. Each testbed shows the technologies committed to the project during its first phase (M1-M15) and all technologies planned to be available after the first half of the project (M16). After individually presenting every testbed, the section concludes with the summary of all technologies available in the integrated testbed of 5G-TRANSFORMER.

3.1 5TONIC

The 5TONIC laboratory includes a solid baseline of facilities, infrastructure and equipment to support advanced experimentation in the 5G virtual network function and wireless systems areas. In this respect, the laboratory offers a datacentre with space for 24 racks, including two racks for communications among these racks and with other platforms. 5TONIC provides access to a common infrastructure with specific-purpose hardware, to assist in experiments, trials and demonstrations with 5G network technologies, as well as to commodity hardware, which allows a cost-effective approach to configure different network topologies of variable size and capacity. Figure 3 presents the 5TONIC infrastructure as it is available nowadays. We present the list of components offered by 5TONIC, starting from the bottom-left part of such figure.

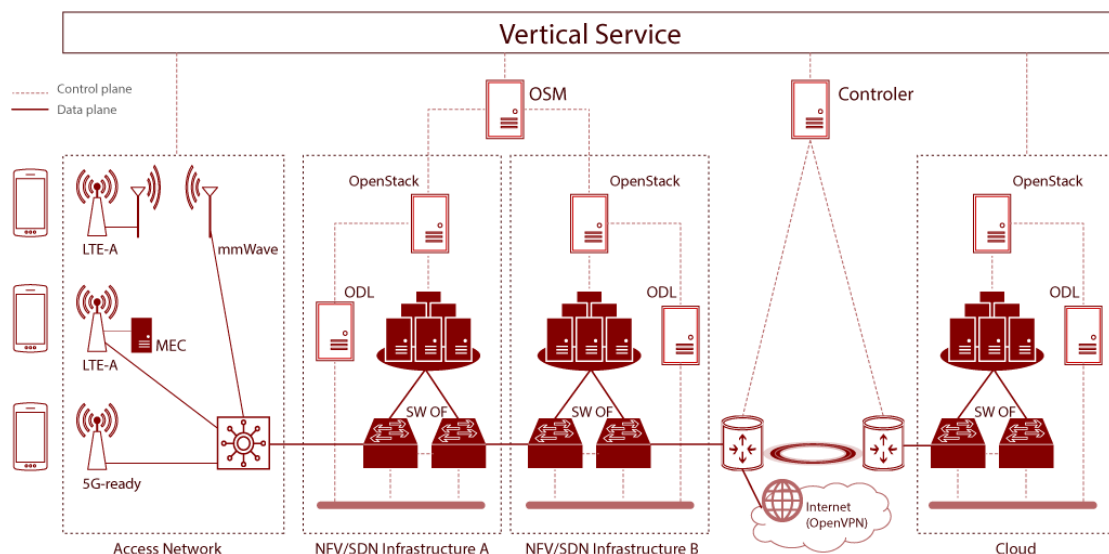

FIGURE 3: 5TONIC INFRASTRUCTURE

With respect to the access network, the 5TONIC infrastructure includes equipment to support advanced experimentation with 5G-ready equipment, commercial LTE-A base stations implementing different functional splits and Software Defined Radio (SDR) systems. LTE-A equipment will allow the deployment of 3GPP rel. 15 extensions to test early 5G scenarios. The SDR equipment consists of a set of 2 eNodeB with 8 FPGA cards, to run high speed and computationally intensive physical layer operations in WiFi/LTE, 4 radio frequency transceivers and a real-time controller, able to execute MAC and PHY control algorithms with micro-second resolution. Driven by the 5G vision, which considers to extend the use of the radio spectrum, the infrastructure also supports communications in the frequency band between 30Ghz and 300Ghz

(mmWave), as well as low frequency communications. In particular, the test-bed includes several scalable SDR platforms, along with a set of 60Ghz down/up-converters, supporting the generation and reception of arbitrary signals in the frequency bands under consideration. 5TONIC provides several end-user terminals to connect to all these access networks: smartphones, USB dongles and LTE-A routers.

The NFV/SDN infrastructure A equipment includes 3 high-power servers to test real deployments, each equipped with 8 cores in a NUMA architecture, 12 modules of 16GB RDIMM RAM and 8 10Gbps Ethernet optical transceivers with SR-IOV capabilities. These servers are connected between them to deploy the data planes, by using a switch with 24 10Gbps Ethernet optical ports. To complement this infrastructure, the laboratory provides an NFV/SDN infrastructure B including a set of 30 mini-PC computers with DPDK capabilities, supporting the experimentation with Virtual Network Functions (VNFs) at smaller scale. Infrastructures A and B are interconnected using high-performance OpenFlow switches. Furthermore, the Management and Network Orchestration (MANO) part of the laboratory includes 4 servers, where each of them includes 4 cores, 2 modules of 8GB RDIMM RAM and 4 1Gbps Ethernet cards. The MANO is implemented using OSM version 2 for the service and network orchestration, OpenStack for the virtual infrastructure management (VIM) and OpenDayLight (ODL) for the SDN assisted part. The different elements of the test-bed can be flexibly interconnected using a pool of 50 low-power single board computers, with Ethernet and WiFi network cards, which can be configured to deploy diverse network functionalities, such as OpenFlow switches, wireless routers, WiFi access points, firewalls or load balancers.

The Cloud part of the laboratory is composed of medium-performance servers as compute/storage nodes as well as miniPCs to deploy OpenStack and ODL controllers. Servers are interconnected using OpenFlow switches, using a similar approach as in the SDN/NFV infrastructures. The goal of this system is to deploy servers and/or applications that can be used to perform end-to-end trials.

To interconnect SDN/NFV infrastructures with the Cloud side, the 5TONIC laboratory includes a metro-core network, which is connected to the components described before by means of dedicated gateways. The metro-core network setup is composed of IP/MPLS and optical devices. The core control plane test-bed is conformed by GMPLS nodes with software developed internally. The experimental setup is built with real and emulated nodes. The latter nodes run in an Ubuntu server Linux distribution. Each emulated node implements a GMPLS stack (including RSVP, OSPFv2 and PCEP) and a Flexible Node emulator.

Finally, the Vertical Service layer allows users of 5TONIC to prepare, deploy and analyze their trials. Remote users can connect to this service by using a dedicated OpenVPN.

Table 1 presents all technologies available right now (first phase) and those that will be available after M15 (second phase) in 5TONIC, grouped by technologies defined in Annex I.

TABLE 1: 5TONIC TECHNOLOGIES

Technologies	Components	
	First phase	Second phase
T1.a	USRP cards and OAI software, LTE-A microcells, virtualized EPC, mmWave base stations for fronthaul and backhaul traffic, user equipment for LTE-A. Spectrum licenses: 1.8(FDD-LTE), 2.6 (FDD-LTE), 3.5 (TDD-LTE), 2.4 and 5.2 (Wifi)	C-RAN (radio access with different functional splits), massive MIMO.
T1.d	Mesh optical network with DWDM.	
T2.a	OpenStack with different tenants. Not guaranteeing SLAs yet. "Ericsson RAN orchestrator" that provides network slice using radio and Crosshaul transport equipment.	To be updated in the next deliverable in case more information is available.
T2.b	VNFs implementing routers, firewalls. Service Function Chaining. "Ericsson RAN orchestrator" that provides abstraction of radio and Crosshaul transport resources	VNFs implementing the different components of an EPC.
T2.c	ETSI OpenSourceMANO v2 as MANO controlling several OpenStack as the VIMs. Transport Multi-domain Orchestrator based on NOX platform to orchestrate and provide E2E connection across multiple administrative network domains	ETSI OpenSourceMANO v3 or beyond.
T3.b	MEC extensions to OAI	
T4.a	OpenVPN to access the laboratory.	
T5.b	VNF SIP proxies	
T6.a	WiFi Direct devices.	

3.2 CTTC

The CTTC testbed infrastructure has been designed to allow the experimentation, implementation, testing and demonstration of cutting-edge communication technologies.

In order to reproduce a myriad of communication scenarios the CTTC testbed includes three types of technologies: cloud, radio and packet/optical transport networks.

A key objective and target for the deployment of new testbed capabilities and functionalities is to leverage commodity hardware as much as possible. In this regard,

the radio-related part of the testbed has been implemented relying on standard servers equipped with both 802.11ac and 802.11d NICs. This allows reproducing, without specialized or dedicated appliances, MEC scenarios where the radio transport network offers also both computing and storage resources.

A set of software tools have been deployed to manage and automate the testbed infrastructure aiming at providing the maximum flexibility to the testbed. The goal is to enable supporting multiple and heterogeneous scenarios accommodating a number of technologies, topologies, etc. To this end, the set of supported tools include: image cloning, deploying and configuration, hardware orchestration and software orchestration tools, software repositories and control interfaces for administration and test automation. In a nutshell, such a set of tools allows fast deployment of new software and/or testbed reconfiguration. Specifically, the high level of flexibility of the CTTC testbed allows deploying new software in minutes. For instance, currently CTTC is testing a release of OSMv3 with a few pool of servers. Leveraging the CTTC testbed management tools such a notable large OSMv3 software can be deployed in a short time in any of the servers.

Figure 4 depicts the logical representation of the key elements and technologies constituting the CTTC testbed. Observe that the entire testbed covers different network segments, namely, access, metro / aggregation and core infrastructures. As mentioned above, the whole experimental platform provides different technologies (i.e., radio, packet and optical). In order to automatically set up an end-to-end network service encompassing such myriad of access and transport technologies, the configuration of each domain is coordinated according to a, for instance a hierarchical control model as depicted in the figure. Particularly, the NFV Orchestrator takes over of the end-to-end computation of the network service instructing the underlying technological domain controllers (e.g., Wireless domain VIM, Transport SDN Controller VIM, Core Cloud Orchestrator VIM) to allocate/program the selected resources (i.e., cloud, radio, packet and optical).

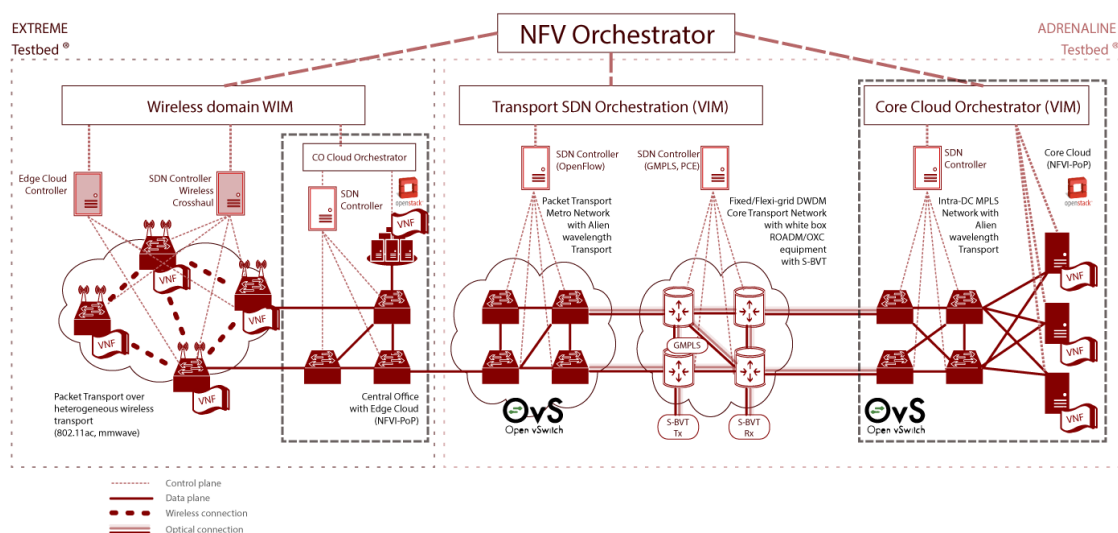

FIGURE 4: CTTC TESTBED INFRASTRUCTURE

As shown in Figure 4, basically the CTTC testbed is divided into two interconnected experimental platforms:

The EXTREME testbed encompassing the radio communication access part/domain. This includes a cloud domain for NFV / MEC purposes.

The ADRENALINE testbed integrating circuit-switched packet and optical transport networks covering both the aggregation and core segments. Likewise, cloud resources are also deployed for NFV objectives.

The wireless testbed (EXTREME) is aimed to demonstrate mobile edge use cases. It includes computation and storage capacities so it is able to reproduce MEC-related scenarios. It includes 16 servers that have, all of them, transport and compute and storage capabilities. Each of the 16 servers have 8 Cores Intel Xeon CPUs, 32 GB RAM, 2TB storage and 3 wireless 802.11ac interfaces besides wired Ethernet interfaces to be used for administration. Additionally, 16 units of 802.11ad cards are available to be placed in any of the servers.

In the EXTREME testbed the wireless part is connected to both a cloud domain and to the packet / optical transport network of the ADRENALINE testbed. The cloud connected to the wireless testbed provides additional MEC computation and storage capabilities to the wireless testbed. The cloud part EXTREME testbed is composed by 8 servers equipped with two Intel Xeon E5-2600v3, 10 cores at 2,4Ghz, 64 GB RAM and two 1TB storage units.

Regarding the control elements (within the EXTREME testbed) mainly rely on deploying a VIM (as defined by ETSI NFV framework) which takes over of the configuration of the wireless network devices as well as the cloud resources to create Virtual Machines hosting targeted VNFs.

The ADRENALINE testbed is formed by a (variable) number of packet switch nodes (using OVS over commodity servers) and four optical nodes interconnected through basic mesh topology where more than 600 km are deployed. The optical domain can rely on both fixed and flexi-grid technologies. To this end, the experimental platform provides both fixed-grid DWDM transceivers (operating at 10Gb/s with 50GHz channel spacing which are embedded on the bordering packet switch nodes); and Sliceable Bandwidth Variable Transceivers (SBVTs) for flexi-grid optical connections supporting super-channels and different bit rates (depending on the variable modulation formats).

The control and configuration of the packet and optical networks is handled by a VIM (or WIM). This basically provides the Transport SDN control functions (encompassing both multi-domain and multi-technology) which leads to coordinate a set of underlying SDN control instances dedicated to handle each involved domains. By doing so, each SDN controller manages the programmability of the packet and optical network elements. Observe, for the optical part, ADRENALINE also supports the legacy control solutions based on distributed GMPLS combined with SDN-oriented solutions such as the centralized Active Stateful Path Computation Element (AS-PCE). For the sake of completeness, the AS-PCE allows computing and instantiating the optical connection setting up which are eventually completed by the distributed GMPLS signalling. Recently specific developments are being made within the optical domain to exclusively programming the infrastructure using a centralized SDN control via standard interfaces such as NETCONF.

One of the main objectives in the context of 5G-TRANSFORMER is to deploy in both experimental platforms forming the CTTC testbed, selected building blocks and

functionalities being targeted within the project architecture. Particularly, the 5GT-SO and 5GT-MTP elements are being considered to be developed and tailored (considering the intricacies of each platform) within EXTREME and ADRENALINE. This will allow validating specific objectives of the project such as the resource federation attained through the interconnection between different 5GT-SOs. Nonetheless, upcoming validations to be conducted within the project are, at time of writing under-discussion, and are notably dependent of the use cases to be demonstrated.

Table 2 presents all technologies available at the CTTC testbed nowadays (in the column “First phase”, which is between M1-M15 of the project), and during the second phase, expected to be in place between M15-M30 of the project. All technologies are listed in Annex I.

TABLE 2: CTTC TECHNOLOGIES

Technologies	Components	
	First phase	Second phase
T1.d	<p>Domain 1, wireless domain: 14 nodes with a total of 132 CPUs and 448 GB RAM Memory and 28 TB storage.</p> <p>Domain 1, wired domain: 2 nodes with a total of 64 CPUs and 256 GB RAM Memory and 2TB storage.</p> <p>Domain 2, optical domain: packet for aggregation (statistical multiplexing) and optical (DWDM) for transport capacity</p> <p>Domain 2 is formed by 4 physical packet switches + a pool of software switches. Additionally, 4 ROADMs/OXCs connected by +650 km of optical fiber is available.</p>	
T2.a	OpenStack with Tenants for slice isolation. Not guaranteeing SLAs.	
T2.b	NS-3 LENA modules (access and core) for mobile network emulation.	
T2.c	OSM controlling several OpenStack as the VIMs. Different SDN controllers (e.g., Ryu, ONOS, etc.) based on different implementations and relying on separated APIs (OFP, NETCONF/YANG) for heterogeneous switching capabilities and technologies	To validate selected functions and interfaces covered by the 5G-TRANSFORMER project with respect to the federation capabilities between Service Orchestrators (SOs), CTTC testbed would support/deploy two SOs to be run within the CTTC platform aiming at providing automatic end-to-end establishment of network

	services through a number of technological domains (e.g., access Wireless and packet/optical transport)
T4.a	OpenVPN to access the laboratory.

3.3 EURECOM

EURECOM has an indoor CRAN testbed based on OpenAirInterface (OAI) deployed in their site in Sophia Antipolis. The Cloud RAN testbed is depicted in Figure 5; it allows testing different functional splits between the Remote Radio Header (RRH) and Baseband Unit (BBU) according to the New Generation Fronthaul Interface (NGFI) specifications [26]. Three options of split between the BBU and RRH are supported:

1. IF5 transports baseband time domain IQ sample.
2. IF4.5 corresponds to the split-point at the input (TX) and output (RX) of the Orthogonal Frequency Division Multiplexing (OFDM) symbol generator (i.e. frequency-domain signals) and transports resources element in usable channel band. Both interfaces guarantee A-law compression.
3. Besides these two interfaces, OAI enables the small cells Networked Functional API (nFAPI) [27] interface specification P5 and P7 between the PHY and the MAC layer, which allows to offload the lower PHY functionality to the RRU.

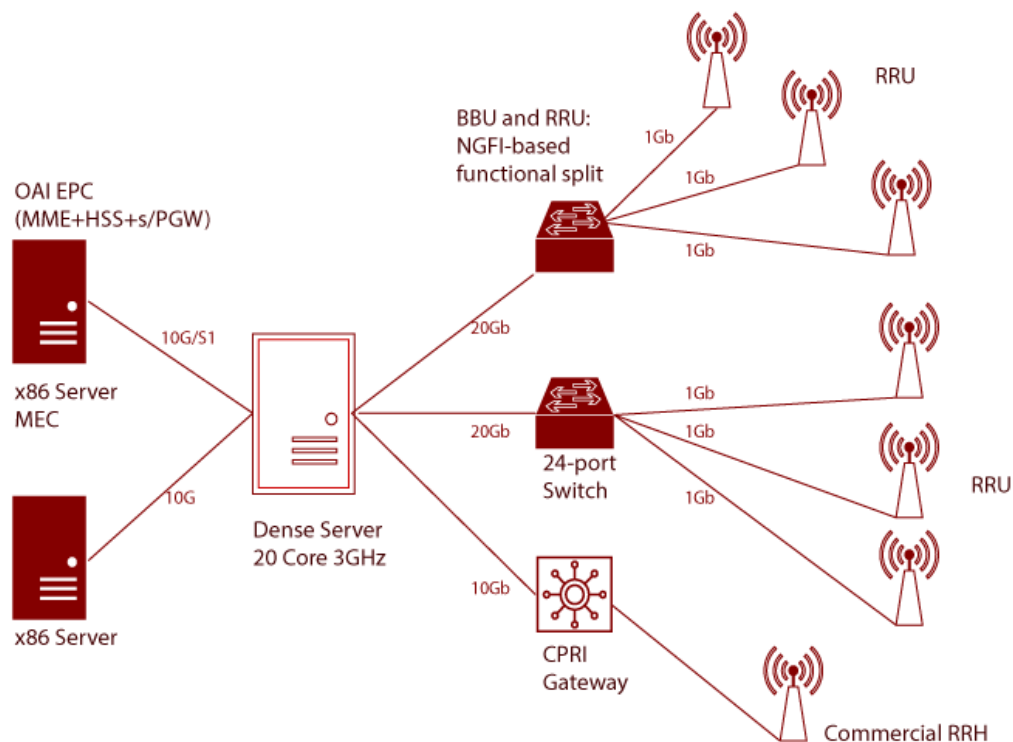

FIGURE 5: EURECOM'S CRAN TESTBED

The BBU is host in a Dense Server with 20 Core running at 30 GHz of frequency. The RRUs are connected to the BBU via high speed Ethernet link. Moreover, a commercial

RRH is also connected to the BBU via a CPRI Gateway. In addition to the CRAN, the testbed integrates a vEPC and a Mobile Edge Computing (MEC) platform.

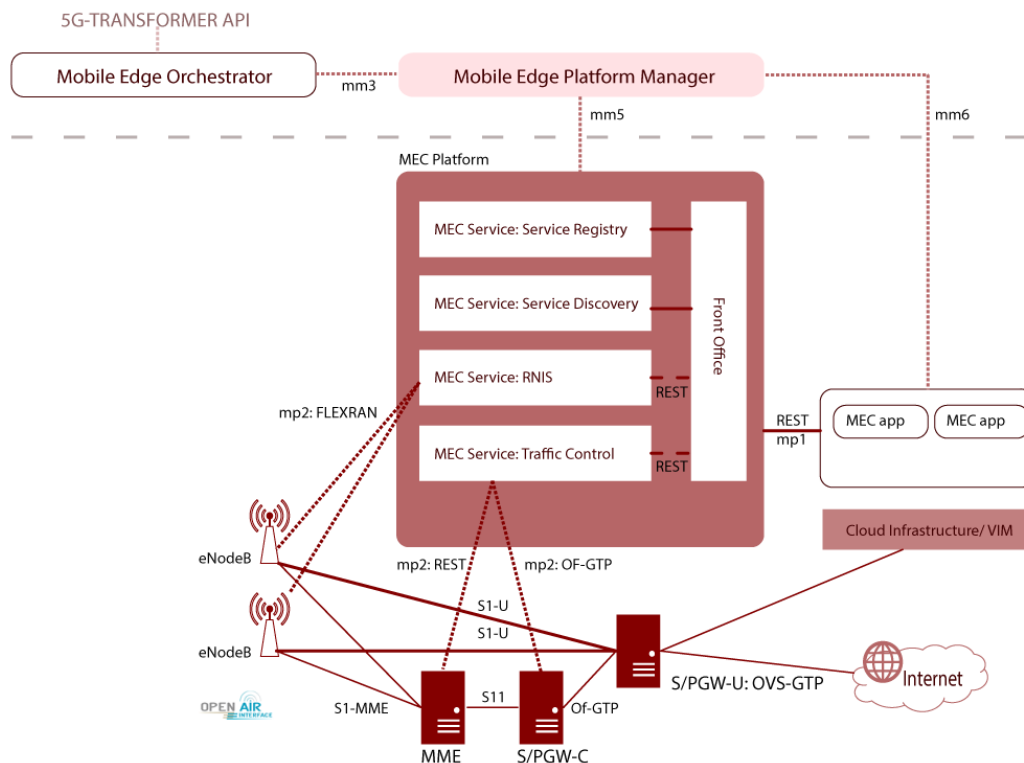

FIGURE 6: EURECOM'S MEC TESTBED

Figure 6 depicts the MEC testbed. The MEC platform (MEP) is composed by a Front office entity that interacts with the MEC applications via the mp1 interface, the MEP Manager via the mm5, and the available services via internal interfaces. Both mp1 and mm5 interfaces are based on REST API. The MEP provides four MEC services: Service registry, Service Discovery, Traffic Control and Radio Network Information Service (RNIS). The traffic control exposes a REST API for both mp1 and Mm5 interfaces, to offload specific traffic to MEC applications. The traffic control is based on a SDN controller, which interacts with mobile network, and specifically with the SGW-U via mp2 interface (REST API), to enforce new rules to offload specific traffic to the MEC application. Indeed, the MEC testbed is based on a modified version of OAI (both eNodeB and EPC). At the EPC level, OAI has been modified to allow the split of SPGW to separate the control plane and data plane. The SPGW-C is in charge of the control plane (creation of bearer, etc.), while the SPGW-U handles the data plane. The SPGW-U is based on a patched version of OpenVSwitch (OVS) tool, which is able to match GTP header. Moreover, the MME has been modified to communicate with the MEP to provide information on the connected UEs. Regarding the eNodeB, OAI has been modified in order to integrate the FlexRAN protocol (mp2), which allows the RNIS service to communicate with the eNodeB to gather statistic on UE, and to provide the RNIS API.

Finally, the EURECOM testbed allows also the creation of end to end Network Slices, composed by a vEPC slice and RAN slice. A proprietary slice orchestrator is used, which allows via a high-level blueprint template to define the vEPC and RAN sub-

slices, and interacts with a local NFVO to instantiate and configure a vEPC sub-slice and enforce the RAN subslice at a eNodeB (PNF).

Table 3 shows technologies deployed at the EURECOM testbed now (in the column “First phase”, which is between M1-M15 of the project), and during the second phase, expected to be in place at M15 of the project. All technologies are listed in Annex I.

TABLE 3: EURECOM TECHNOLOGIES

Technologies	Components	
	First phase	Second phase
T1.a	C-RAN based OAI deployed in EURECOM corridors.	
T2.a	RAN and EPC slice creation and instantiation using a customised version of OAI and a Slice Orchestrator	Improve the system to integrate it with a MANO.
T2.b	Virtualized EPC and part of eNodeB. A programmable RAN based on FlexRAN protocol (OAI-based). A SDN-based EPC architecture (split of S/P-GW: S/P-GW-C and S/P-GW-U).	
T2.f	End-to-end performance measurements for LTE and C-RAN (including core) with OAI	
T3.b	MEC platform based on OAI. It implements mp1 (REST) and mp2 (FlexRAN and OpenFlow) interfaces. It provides the following MEC services: Traffic redirection, RNIS (a part), Service Registry and Service Discovery.	Enrich the RNIS API and integrate with a NFV MANO.

3.4 ARNO

The Advanced Research Networking (ARNO) testbed (shown in Figure 7) features an SDN-controlled Data Center testbed, an SDN-controlled wired/wireless access testbed, and an SDN-controlled IP/MPLS over Optical Network testbed. In particular, ARNO features an installation of OpenAirInterface (OAI) for RAN and EPC with some Universal Software Radio Peripherals (USRPs). By accessing the ARNO testbed experimenters can combine testbed components in a different and flexible way to reproduce complex networking scenarios, spanning from Data Center and access network to aggregation/edge network and optical core networks and different eNB functional splits.

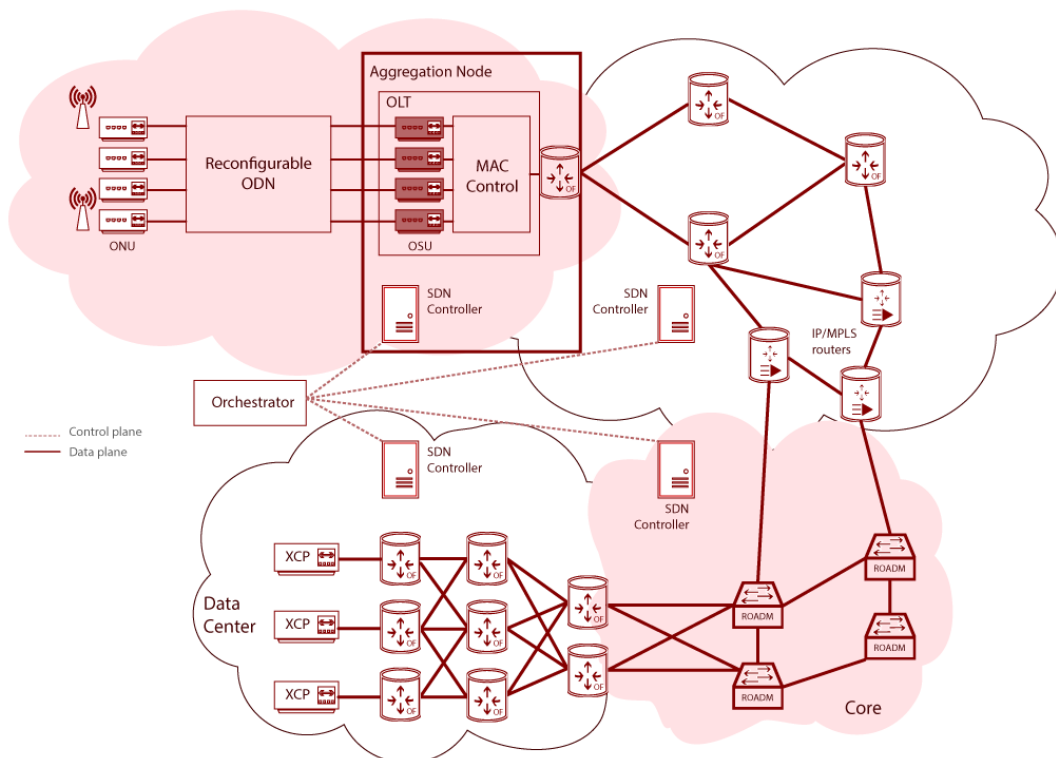

FIGURE 7: ARNO TESTBED

In particular the 5G Access segment data plane consist of the following devices: mini-PCs (Up-board) equipped with an Intel Atom x5-Z8350 Quad Core Processor and hosting Ubuntu 14.04 LTS with a 4.7 kernel (directly precompiled by OAI team); desktop servers with Intel Xeon E5620 and hosting Ubuntu 14.04 with 3.19 low-latency kernel; mini-ITX featuring an Intel I7 7700 Quad Core @ 4.0 GHz and hosting Ubuntu 14.04, 3.19 low-latency kernel; desktop with an Intel i7 4790 @ 3.60 GHz and hosting Ubuntu 14.04 with 3.19 low-latency kernel; lime SDR; Huawei E3372 LTE dongles utilized as User Equipments (UEs); Ettus B210 for implementing the RF front-end.

The aforementioned devices can host virtualised and non-virtualised mobile network functions and their interconnection can be reconfigured by reconfiguring a switch to which they are connected as depicted in Figure 8.

The mobile network software is based on Open Air Interface.

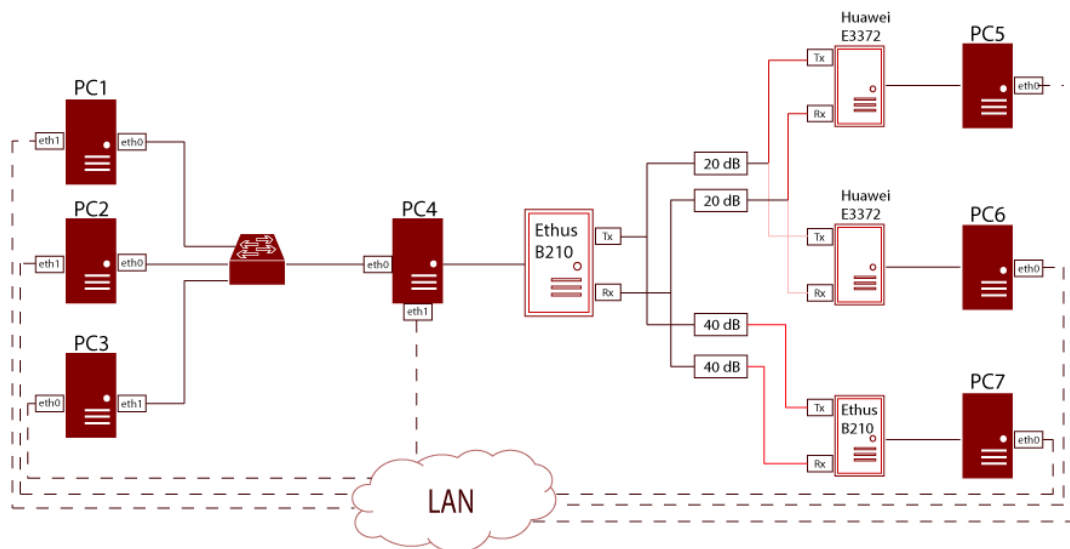

FIGURE 8: ARNO TESTBED 5G ACCESS SEGMENT

The wired access segment data plane consists of Calix XGS-PON at 10 Gb/s uplink and downlink. In addition ARNO features reconfigurable TWDM-PON prototype whose data plane is based on two ONUs and two OSUs @ 10 Gb/s implemented through two Altera Transceiver Signal Integrity Development Kits, equipped with field-programmable gate array (FPGA) Stratix IV GT Edition (i.e., EP4S100-G2F40I1N). The wired access segment control and management plane is based on Openflow and 10 G-EPON Multi-Point Control Protocol (MPCP).

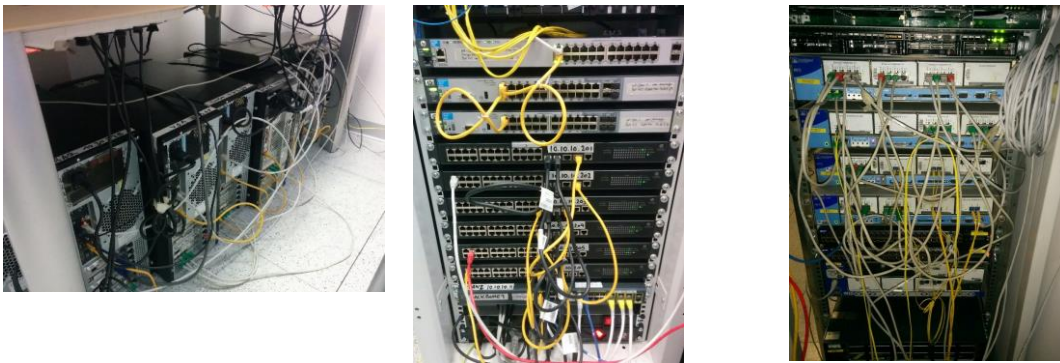

FIGURE 9: ARNO METRO AGGREGATION (OVS SWITCHES, HPE SWITCHES, ROUTERS FROM LEFT TO RIGHT)

The Metro/aggregation network (shown in Figure 9) data plane consists of OpenFlow commercial switches (HPE), OpenFlow switches based on OvS, Juniper M10/M7i routers, Cisco Router VXR7200. The Metro/aggregation control/management plane is based on PCE (stateful, SR-enabled), BGP-LS SDN controllers (Ryu, ONOS, POX), Segment Routing API (on Juniper).

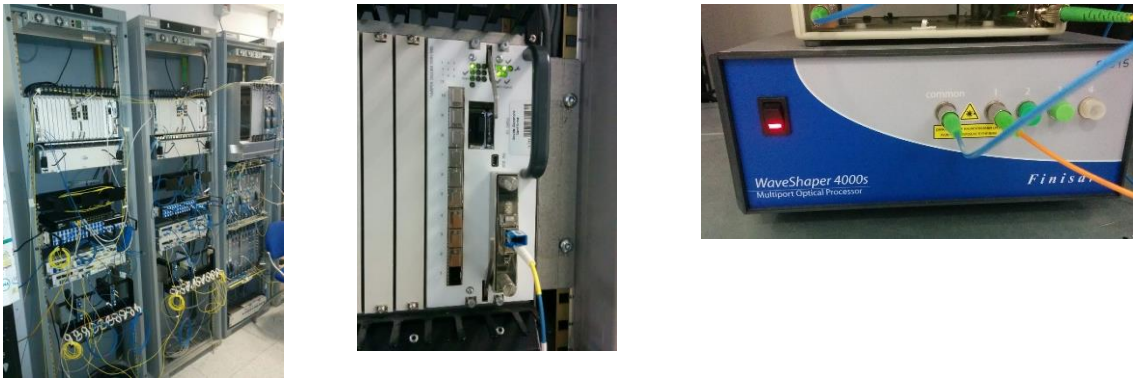

FIGURE 10: ARNO TESTBED CORE NETWORK (FROM LEFT TO RIGHT: ERICSSON SPO-1410, 100G CARDS, WSS)

The ARNO Core network data plane (shown in Figure 10) consists of 2 ROADMs Ericsson SPO-1410 with transceivers equipped with 10G and 100G cards (muxponders), WSSs Finisar Waveshaper, and a Lumentum ROADM-20 whitebox. The ARNO Core network control plane is based on GMPLS (RSVP-TE) and PCE, BGP-LS, SDN OpenFlow and NETCONF (confd based), ONOS.



FIGURE 11: ARNO DATA CENTRE SEGMENT (FROM LEFT TO RIGHT: DATA CENTER, OPENSTACK AND ONOS, OPENSTACK + ONOS + INSTANTCONTIKI)

The ARNO data centre at the edge (shown in Figure 11) data plane features the following devices: edge network deployed by 2 Workstations Intel® Core™ i7-4790 CPU @ 3.60GHz × 8, Memory 8 GiB with Linux - Ubuntu 16.04 with six Ethernet interfaces (2 native + 4 added) hosting OVS instances and/or Mininet topology; data centre network deployed by 5 servers running enhanced Open vSwitch (OVS) and 3 OpenFlow-enabled HP switches (2 HP3500, 1 HP3800); cloud deployed by 1 server DELL PowerEdge R630 Intel(R) Xeon(R) CPU E5-2650 v3 @2.30GHz Memory 64 GiB hosting OpenStack compute nodes and gateways; fog deployed by 5 mini-pcs (FitPC 2i) hosting IoT nodes and/or emulated IoT environment (InstantContiki). The ARNO data centre control plane/orchestestrator/hypervisor consists of OpenFlow controllers (NOX/Floodlight/ODL/ONOS), OpenStack controller and XCP Virtual Machine Manager SONA framework for SDN-based OpenStack networking, Orchestrators for cloud DCs and edge SDN networks.

The ARNO testbed features several external connectivities: availability to provide e2e tunnelling IPsec (gateway host) without firewall constraints, GRE L3 (gateway host, router), GRE L2 (gateway host); availability to expose SSSA island with multiple domains exploiting eBGP with single/multiple AS; availability to act as TE stub or transit domain Inter-AS OSPF TE and RSVP-TE (Juniper). The ARNO testbed can be reached through a 1GbEthernet from GEANT through GARR network and it is interconnected with Fed4FIRE through GARR.

TABLE 4: ARNO TECHNOLOGIES

Technologies	Components	
	First phase	Second phase
T1.a	USRP cards and OAI software, LTE-A microcells, virtualized EPC, user equipment for LTE-A. Channel Bandwidth: 5MHz, 10MHz, and 20 MHz (FDD-LTE). C-RAN with Option 8 and Option7-1 functional splits support. Emulated IoT environment (InstantContiki). XGS-PON.	Wireless transmission in unlicensed bands.
T2.a	OpenFlow controllers (NOX/Floodlight/ODL/ONOS) OpenStack controller and XCP Virtual Machine Manager SONA framework for SDN-based OpenStack networking Orchestrators for cloud DCs and edge SDN networks. Reconfiguration/Orchestration in SDN network domains.	Plan to include joint orchestration across SDN and Cloud domains.
T2.b	Virtualized DU, CU, and EPC via Virtualbox, KVM, Docker container.	
T2.c	Shell-based flexible functional split (Option 8 to Option 7-1) Reconfiguration/Orchestration in a single domain. Multidomain resource advertisement based on BGP-LS.	Flexible functional split (Option 8 to Option 7-1) Reconfiguration/Orchestration based on Kubernetes in a single domain.
T2.d		
T2.f	End-to-end performance measurements for LTE and C-RAN (including core) with OAI	
T3.b		Plan to include OAI MEC for use case testing.
T4.a	ARNO testbed federated in Fed4FIRE through jFed where users can access LTE/C-RAN components. Also provides OpenVPN, GRE tunnels and IPsec tunnel to access the laboratory.	

3.5 Integrated testbed

Table 5 summarizes all technologies available in the four different testbeds of the project. These technologies can be used by the different use cases defined in 5G-TRANSFORMER after these testbeds are properly interconnected.

TABLE 5: TECHNOLOGIES AVAILABLE FOR 5G-TRANSFORMER

Technologies	Components	
	First phase	Second phase
T1.a	<p>USRP cards and OAI software, LTE-A microcells, virtualized EPC, mmWave base stations for fronthaul and backhaul traffic, user equipment for LTE-A. Spectrum licenses: 1.8(FDD-LTE), 2.6 (FDD-LTE), 3.5 (TDD-LTE), 2.4 and 5.2 (Wifi). Channel Bandwidth: 5MHz, 10MHz, and 20 MHz (FDD-LTE). C-RAN with Option 8 and Option7-1 functional splits support. Emulated IoT environment (InstantContiki). XGS-PON.</p>	<p>C-RAN (radio access with different functional splits), massive MIMO. Wireless transmission in unlicensed bands.</p>
T1.d	<p>Mesh optical network with DWDM.</p> <p>Domain 1, wireless domain: 14 nodes with a total of 132 CPUs and 448 GB RAM Memory and 28 TB storage.</p> <p>Domain 1, wired domain: 2 nodes with a total of 64 CPUs and 256 GB RAM Memory and 2TB storage.</p> <p>Domain 2, optical domain: packet for aggregation (statistical multiplexing) and optical (DWDM) for transport capacity</p> <p>Domain 2 is formed by 4 physical packet switches + a pool of software switches. Additionally, 4 ROADMs/OXCs connected by +650 km of optical fiber is available.</p>	
T2.a	<p>OpenStack with different tenants. Not guaranteeing SLAs yet. RAN and EPC slice creation and instantiation using a customised version of OAI and a Slice Orchestrator. OpenFlow controllers (NOX/Floodlight/ODL/ONOS) OpenStack controller and</p>	<p>Integration with MANO. Plan to include joint orchestration across SDN and Cloud domains.</p>

	XCP Virtual Machine Manager SONA framework for SDN-based OpenStack networking Orchestrators for cloud DCs and edge SDN networks. Reconfiguration/Orchestration in SDN network domains.	
T2.b	VNFs implementing routers, firewalls, EPC and part of eNodeB. Service Function Chaining. NS-3 LENA modules (access and core) for mobile network emulation. A programmable RAN based on FlexRAN protocol (OAI-based). A SDN-based EPC architecture (split of S/P-GW: S/P-GW-C and S/P-GW-U). Virtualized DU, CU, and EPC via Virtualbox, KVM, Docker container.	VNFs implementing the different components of an EPC.
T2.c	ETSI OpenSourceMANO v2 as MANO controlling several OpenStack as the VIMs. Different SDN controllers (e.g., Ryu, ONOS, etc.) based on different implementations and relying on separated APIs (OFP, NETCONF/YANG) for heterogeneous switching capabilities and technologies. Shell-based flexible functional split (Option 8 to Option 7a) Reconfiguration/Orchestration in a single domain. Multidomain resource advertisement based on BGP-LS.	ETSI OpenSourceMANO v3 or beyond. Federation of testbeds. Interconnection (at some extent) of (two) Service Orchestrators. Flexible functional split (Option 8 to Option 7a) Reconfiguration/Orchestration based on Kubernetes in a single domain.
T2.f	End-to-end performance measurements for LTE and C-RAN (including core) with OAI	
T3.b	MEC platform based on OAI. It implements mp1 (REST) and mp2 (FlexRAN and OpenFlow) interfaces. It provides the following MEC services: Traffic redirection, RNIS (a part), Service Registry and Service Discovery.	Enrich the RNIS API and integrate with a NFV MANO.

T4.a	OpenVPN to access the laboratory. ARNO testbed federated in Fed4FIRE through jFed where users can access LTE/C-RAN components.
T5.b	VNF SIP proxies
T6.a	WiFi Direct devices.

4 Inter-testbeds measurements

In order to check the feasibility to connect the four trial sites of the project, and to run the different tests of the use cases that will be defined later in this document, we have defined a set of measurements between all sites. We will define the methodology to collect all the required data, the analysis of such information and a brief overview about the deployment options.

4.1 Methodology

The inter-testbeds measurements consist of collecting the Quality of Service (QoS) metrics of the transport between each pair of the aforementioned trial sites through the Internet: 5TONIC, CTTC, EURECOM and ARNO. Accordingly, we have six point-to-point links to be measured.

The QoS attributes that we are focusing on are the throughput and the latency. To collect these two attributes, we realize two separate experiments. In the first one, we collect measurements regarding the Round Trip Time (RTT), while in the second experiment, we measure the throughput in bidirectional transmissions. These results are necessary to analyze the feasibility of interconnecting the four different trial sites and find a final topology to deploy the integrated testbed.

To collect the required measurements, we developed a client script in bash, using the ping application to measure the round-trip time, and the iperf application [31] to gather the throughput samples. The iperf application enables different test configurations wherein traffic can be carried over TCP or UDP protocols, in one-way or two-ways flow directions, and for different experiment durations. The measurements we achieved in this document are based on TCP protocol, in which the client script invokes a 1-minute iperf-based measurement every 29 minutes, and all tests last 4 days.

The arguments to invoke the script include the type of the experiment (experiment 1 or experiment 2) and both the IP address and TCP port of the other end (i.e., the server or sink). When the script is invoked with experiment 1 as a parameter, the ping command is executed (Test 1) to estimate the RTT between sites A and B considering no background traffic between these two sites. When the script is invoked with experiment 2, the iperf performs a bidirectional test in which both client and server (Sites A and B, respectively) send traffic to each other in both uplink and downlink directions (Test 2).

Figure 12 portrays this experiment.

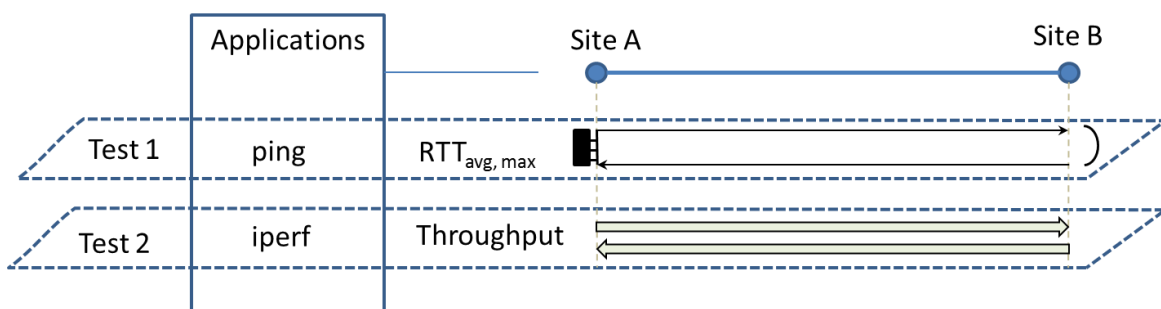

FIGURE 12: REPRESENTATIVE VIEW OF THE PING AND IPERF TESTS

In each experiment, one peer runs the server (sink) application, which is basically an iperf acting as a server, while the other one runs the client (source) script. In the following, every link will be represented with the format B-A, where B is the server and A is the client.

4.2 Performance Analysis

In this section, we evaluate the feasibility of deploying functions in a distributed way across the aforementioned sites, taking into account the results of tests performed on inter-site links. The functions we consider that can be either VNFs that make up a network service, or components of the management and orchestration architecture. For network services, as most use cases require mobile communication services, studying the deployment requirements of an LTE mobile network is central. As for the management and orchestration functions, the modularity of the 5G-TRANSFORMER architecture makes it possible to instantiate separately, if necessary, its 5GT-VS, 5GT-SO and 5GT-MTP layers. The goal is to get benefit from the functional specificities offered (for example the MEC platform) by a site or to achieve federation of services and resources.

Now, we present the results of our measurement campaign regarding the inter-sites latency and the achieved throughput. We then propose a deployment topologies with a respect to the best approach to adopt for efficient implementation and deployment for the different use cases.

4.2.1 Inter-sites latency

Figure 13 (Figure 14, respectively) represents the average RTT (maximum RTT, respectively) values (in ms) obtained in test 1, when performing the ping application. We use boxplots to present the results as we want to focus on the variability of the latency and visualize its distribution. We observe a low dispersion for the average RTT (Figure 13) as all the packets take approximately the same time for a round trip. The 10th and 90th percentiles are so close that they nearly overlap. The median values range from 15ms for the 5TONIC-CTTC link to 50 ms for CTTC-EURECOM.

The maximum RTT values (Figure 14) have greater variability, only the 5TONIC-EURECOM and ARNO-EURECOM links have quartiles close to the median, and the extreme values of the 20ms medians between 5TONIC-CTTC and 70 ms for CTTC-ARNO.

Use cases with low latency requirements may be satisfied with the average value measurements, while applications that have critical communications require packet delay guarantee will only consider the maximum values for the obtained RTT.

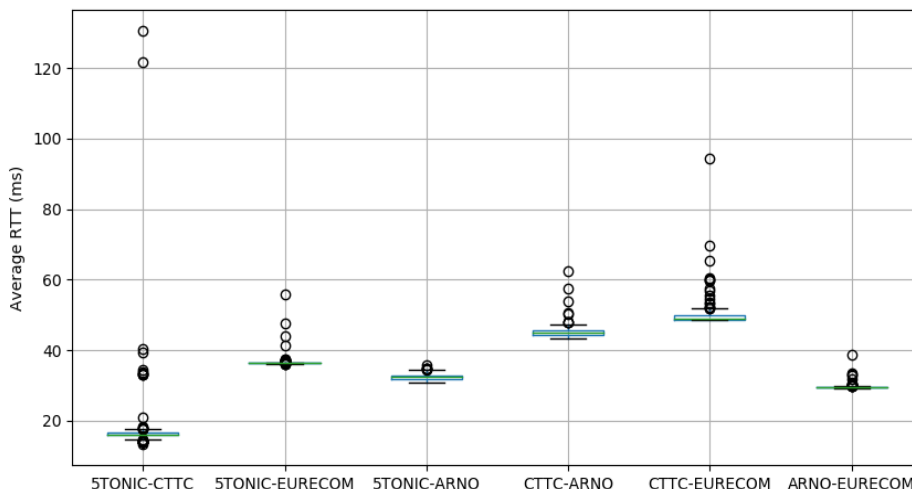

FIGURE 13: AVERAGE RTT BOXPLOTS BETWEEN THE TRIAL SITES WITHOUT BACKGROUND TRAFFIC. THE BOXPLOTS INCLUDE THE 10TH, 25TH, MEDIAN, 75TH, AND 90TH PERCENTILES OF THESE RTT

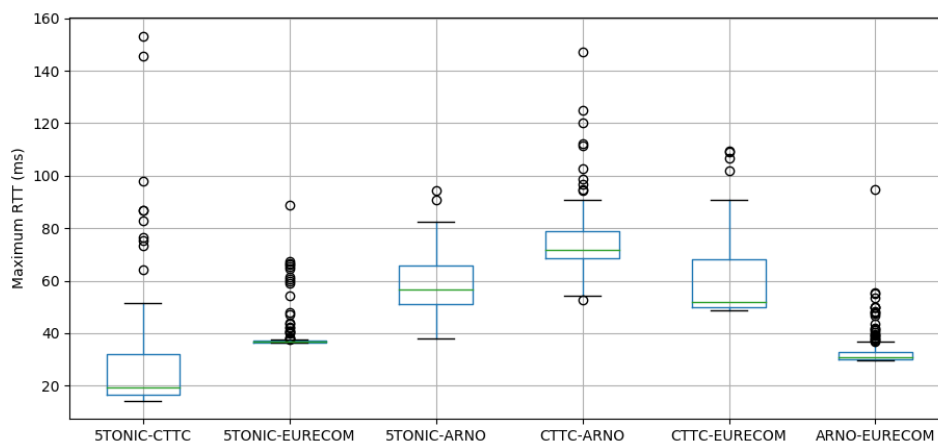

FIGURE 14: MAXIMUM RTT BOXPLOTS BETWEEN THE TRIAL SITES WITHOUT BACKGROUND TRAFFIC. THE BOXPLOTS INCLUDE THE 10TH, 25TH, MEDIAN, 75TH, AND 90TH PERCENTILES OF THESE RTT

4.2.2 Inter-site throughput

This test campaign consists of measuring the throughputs of the inter-site links. The tests are bidirectional and performed individually. We evaluate the flow in both directions, one after the other. The tests have been performed during four days.

Figure 15 shows the uplink and downlink throughput (in Mbps) between the different trial sites during four days. The curves show some flow rates are strongly asymmetrical; there is a large difference between the uplink and downlink path, particularly for links that end in the site ARNO. The flow is also fluctuating during the observation, this phenomenon is not necessarily relative to a specific link, and it can appear only in one direction.



FIGURE 15: UPLINK AND DOWNLINK THROUGHPUT BETWEEN TRIAL SITES (TESTS RUN DURING FOUR DAYS)

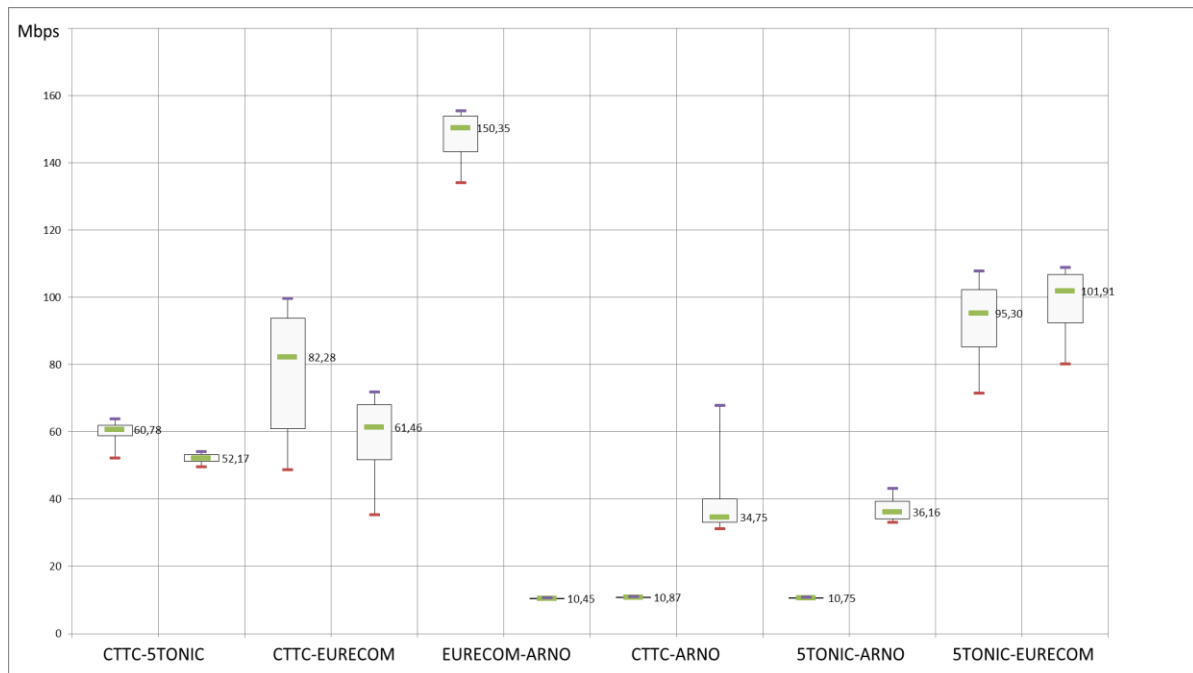

FIGURE 16: REPRESENTATION OF THE MEASUREMENT DATA IN THE FORM OF A BOXPLOT FOR THE UPLINK AND DOWNLINK DIRECTIONS

Figure 16 presents the throughput results (Mbps) in boxplots between each pair of trial sites. The figure reveals a wide range of performance regarding the throughput rate obtained inside each two pair of trial sites link and between these links. Indeed, we observe a large fluctuation for the throughput rates for the CTTC-EURECOM, CTTC-ARNO, and 5TONIC-EURECOM links with medians around 82.28Mbps between CTTC and EURECOM, and up to 102Mbps between 5TONIC and EURECOM sites. Regarding the throughput dispersion between the uplink and downlink directions, we note a high difference in cases of EURECOM-ARNO, CTTC-ARNO, and 5TONIC-ARNO links. This difference ranges from 23.88Mbps to 139.9Mbps. While we observe a certain symmetry between the uplink and downlink throughput rates in case of CTTC-5TONIC.

We believe that the dispersion is due to the background traffics between the sites during the measurement campaign.

4.2.3 Deployment Options

Sites can provide infrastructure resources to support either the placing of VNF in a large geographical area or the distributed deployment of 5G-TRANSFORMER components. In the first case, the typical scenario includes users (devices, cars) that are communicating with applications hosted in a service provider premises. This setup requires a mobile network to enable wireless connectivity services as well as a virtual or physical machine to host application servers. The mobile network can be provided as a network service, which is composed of VNFs dedicated to form the control plane and the user plane. The description of the testbeds provided in the previous section allows the following statement:

- LTE access is available on every site:

- Core network is available on every site: as VNFs deployed in virtualized infrastructure or in physical machine (EURECOM)
- Cloud resources for application deployment: all sites except EURECOM
- MEC capability: available only at EURECOM

If a demo use case needs to span the control plane of the mobile network (virtualized EPC) over two sites, the inter-site link characteristics have to meet one major latency requirement in LTE defined as the transition time from idle to connected mode. This delay has the maximal budget of 100 ms to complete the procedure, of which only an amount of 20 ms (see Table 16) is left for the message round trip at S1-C interface.

With regard to the user plane, an EPS session can traverse multiple sites. The former comprises two segments: the first one is composed of GTP tunnels between eNB and SGi interface and the last one of IP transport from SGi to application servers. Regardless the use case, the latency required for IP packet one-way transit in RAN (S1-U) is less than 10 ms which imposes the S1 bearer to terminate in the same site. The remaining path depends on the use case (for instance collision avoidance) and the scenarios (tight vs relax latency) which should derive their specific end to end latency budget.

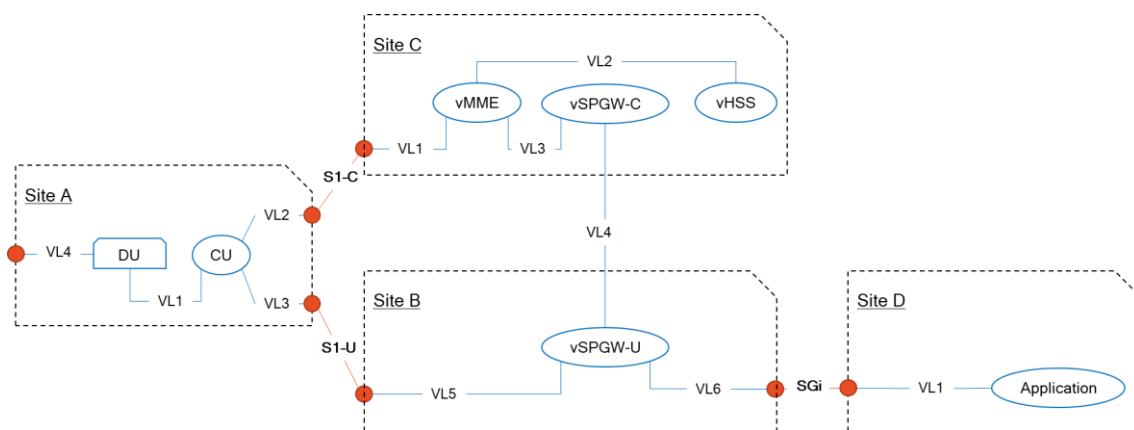

FIGURE 17: AN EXAMPLE OF A MULTI-SITE DEPLOYMENT OF A SERVICE USING MOBILE CONNECTIVITY: SITES A, B, C AND D CAN BE EQUAL IN TWOS

After considering the placing of VNF across multiple sites, we now switch the deployment of 5G-TRANSFORMER components in distributed manner as permitted by its architecture: on one hand, 5G-TRANSFORMER components (5GT-VS, 5GT-SO, 5GT-MTP) are independent and they communicate with each other via well-defined interfaces based on ETSI NFV IFA specifications. On the other hand, the federation of network services and NFVI resources is facilitated at the 5GT-SO-5GT-SO reference point. It lets a service provider enriching the vertical service offers with network functions and virtualized assets delivered by an external service orchestrator. Moreover, the 5GT-MTP SLPOC is able to unify and abstract resources exposed by various technical domains (VIM, WIM, and Mobile Connectivity Controllers) via ETSI NFV IFA005/6 interface without any restriction on their location excepting the maximum latency and the bandwidth necessary for the VNF workload.

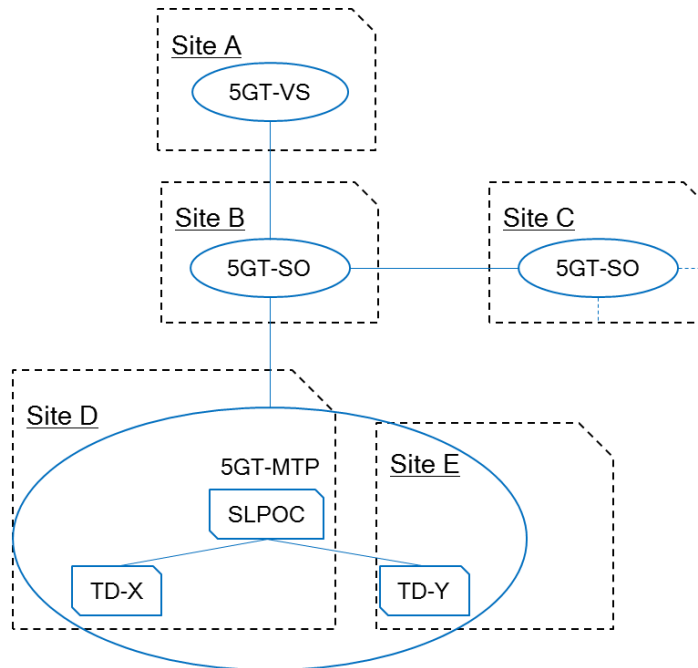

FIGURE 18: POSSIBLE DISTRIBUTED DEPLOYMENT OF 5G-TRANSFORMER COMPONENTS ACROSS MANY SITES: A, B, C, D AND E CAN BE EQUAL TWO BY TWO

5 Initial planning of the Proof of Concepts

Real life Proof-of-Concepts (PoC) will be built by verticals on top of the integrated testbed of the 5G-TRANSFORMER project, which includes, among others, the novel technology components developed in WP2, WP3 and WP4. These PoCs will allow to proof experimentally that all the conceived building blocks can work together to fulfil the system and vertical requirements, validating the main elements and findings of the project.

In the initial stage of the project, a clear picture of all the needs that are specific to a particular vertical industry has been provided in [5]. In particular, representatives from all vertical industries involved in this project have provided their vision of how 5G will enable the development of new use cases mapped into three clusters: (1) Mission Critical Services, (2) Massive IoT and (3) Enhanced Mobile Broadband. Functional and non-functional requirements derived from the set of identified use cases have been elaborated illustrating how 5G, and in particular the solution proposed by the project, will be able to accommodate significantly different requirements at the same time. Each of the five verticals involved in the project has then proposed a preliminary selection of use cases as potential candidates for the final demonstration.

This section presents a description of how these use cases will be deployed for demonstration and validation, by means of specific PoCs. These PoCs are designed to test particular technologies and/or functionalities and, the integration of all PoCs will allow the testing and demonstration of the particular use case. In particular, each vertical provided the following information:

- An in-depth description of the planned PoCs, including the logical architecture with the main VNFs/VAs components;
- A preliminary planning of the expected PoC releases indicating:
 - What technologies and functionalities will be required and tested at each stage. These technologies and functionalities are presented in the summary table of each use case below, and they are based on the lists we have elaborated and which are available in Annex I and Annex II respectively.
 - How the verification will be realized.
- A scheduling of the planned releases including the final demonstration of each PoC.

A set of summary tables comparing functional, technology and other requirements, KPI and scheduling required by each vertical is reported in Section 5.6.

5.1 Automotive PoC

5.1.1 Description

The automotive PoCs aim to implement an Intersection Collision Avoidance (ICA) service that, thanks to a communication among vehicles and an external entity, is able to calculate in real time the probability of collision and the speed profile; and it subsequently reacts. providing a proper warning to the driver or acting on emergency

brakes. The application should be deployed ensuring the coverage of a given percentage (i.e. 90%) of more dangerous intersections in a given geographical area³.

In order to validate the arbitrator, the final PoC will include a video streaming service with a lower priority running in parallel on board. The demonstrator indeed is that indeed shall verify that the ICA application is effectively served even in the event of a lack of resources at the expense of the eventual lower priority service requested in parallel.

The main idea is to extend the capabilities of the currently implemented ICA application, which is entirely based on the use of (local) vehicle sensors. Indeed, thanks to the communication interface among vehicles and infrastructure, it is possible to extend the vehicle sensing capability beyond buildings and obstructions.

This service, present at intersections and named “Extended Sensing for ICA”, is designed to detect and signal those incoming vehicles that could generate a dangerous situation for any road users. In this way, the human errors upon a possible collision are detected, can be reduced to the minimum, or even eliminated, making transportation safer and providing a significantly better Quality of Experience. Clearly, the higher the number of intersections covered, the more effective the service.

To make it possible, the 5G-TRANSFORMER architecture must assure a high speed mobile network with minimal latency (“extended vehicle detection” time must be below 20ms). Such latency requirements imply that computation capabilities must be available as close as possible to the monitored intersection, i.e., to use a Multi-access Edge Computing (MEC) platform.

It is not the goal of the automotive vertical to get involved in the network deployment, nor to indicate a specific deployment of Virtual Network Functions (VNFs) or Virtual Applications (VAs); rather, it specifies the required level of Quality of Service (QoS) (e.g., end-to-end latency and service request loss probability).

It is instead up to the Service Orchestrator (SO) to determine the VNF/VA deployment and resource allocation, so that the requirements provided by the automotive vertical are satisfied, under any system traffic load. Furthermore, resources allocation should be optimized, so that the required QoS is met with minimum use of resources, hence minimum cost for the vertical.

More in detail, upon requesting an “Extended Sensing” service, the vertical could specify:

- The geographical area to be covered.
- The percentage of top dangerous intersections to be covered.
- The time/day when such a request applies (the request may indeed depend on time of the day, day of the week, or time period of the year). The calculation of rush hours and how dangerous a given intersection should be done on the basis of all data via via collected.

Each vehicle periodically (e.g., every 0.1 s) generates Cooperative Awareness Messages (CAMs), including the vehicle position, speed, heading, among others. As

³ The calculation of the most dangerous intersections in a given area could be done by a cloud service on the basis of the traffic data and incidents collected in a given time period

depicted in Figure 19, in our example CAMs are transmitted as V2I unicast messages to the (v)eNB covering the area of interest (e.g., urban intersection). Messages are then forwarded to a Cooperative Information Manager (CIM). The CIM stores the most recent CAMs sent by the vehicles travelling over the geographical area of interest.

Then, an ad-hoc algorithm, acting as an extended sensor, processes the information collected by the CIM and decides if it is necessary to signal any upcoming vehicle (“extended object detection”) at risk of collision, through an asynchronous message. Vehicles that have been notified about the risk of collision, feed their on-board ICA application, which in turn decides how to react, either warning the driver, or activating the emergency break (in case of automated vehicles)

In the case of several intersections covered by different ng-eNBs, vehicles that are physically close to each other may send their CAM to different ng-eNBs. Indeed, it is required that for each vehicle, a CIM collects information related to a circular area centered at the vehicle and of radius of at least X meters, where X could be part of the QoS requirements specified by the vertical. If each CIM is co-located with an ng-eNB, some overlap between the information stored in different CIMs should be ensured by making different CIMs exchange information.

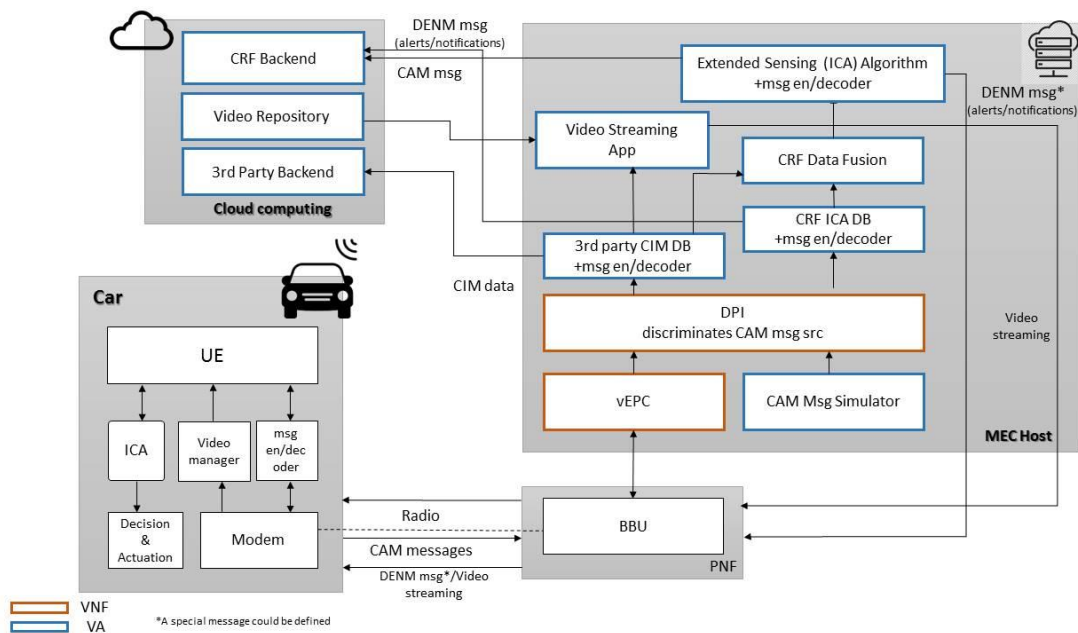

FIGURE 19: ICA DESIGN

The Figure 19 above shows the Automotive PoC design that includes 4 main physical components each of them hosting several virtual modules (VA, VNF).

The car is equipped with an OBU including a simple HMI (UE) for interacting with the driver, a 5G Modem for enabling connection and exchange of CAM and DENM, ad hoc messages and video streaming the ICA on board module interacting with the “Decision & actuation” decides how to react, either warning the driver, or activating the emergency break, the video manager manage the display of video streaming on the UE. A module for encoding/decoding exchanged message is needed onboard.

The BBU is responsible for communication through the physical interface.

The following components are hosted in the MEC:

- CRF ICA Algorithm: a vehicle collision detection algorithm. When a possible collision is detected an alert is generated as DENM message and sent to the involved vehicles.
- Video Streaming App: a video streaming service that can be delivered to the connected vehicles requesting it.
- Data fusion module: fusion between data acquired from the CIM and that retrieved from internal DB
- CRF ICA DB (e.g., to store the sent Alert, specific data about driver, car, ...)
- CIM (Cooperative Information Manager): a VA owned by a trusted third party entity providing for each car maker a database just storing the CAM messages. the CIM should cover an entire geographical area, e.g., the whole city of Turin. Not necessarily one CIM for the whole area. The number and location of the CIM instances should be determined by the SO so that the, e.g., delay constraints are met. CAM messages should be duplicated toward CIM and the automotive DB. CIM should store all fields of the CAM.
- vEPC: receives message toward BBU and forward them to CIM
- CAM message generator: simulate CAM generation for testing
- DPI: discriminates CAM messages sources

The cloud hosts the CRF and the third party Backend:

- The third-party Backend collects all the CIM data to provide also statistics on the dangerous situations detected in a geographical area. For instance, it can detect all cases where the deceleration was higher than a give threshold for each intersection. As a result, the third-party backend will be able to provide a list of intersections within a geographical area, and their associate relevance level.
- The CRF backend collects any relevant data that can be used for providing more general reporting and statistics.
- The video repository contains videos that can be managed by the Video Streaming App at the MEC.

For the demonstration of several test cases relevant for ICA, two vehicles will be used: one equipped with automated breaking that would be available in 2019. The automated vehicle can run only in a safety circuit. A video could be realized, with the automated vehicle in Orbassano (Turin test site).

5.1.2 Initial planning of the PoC

Table 6 summarizes the plan of expected releases of the automotive PoC.

TABLE 6: AUTOMOTIVE PoCs

PoC ID	Description	Functionalities to be tested	Required technologies	Verification	Month
1.1	The vehicle exchanges messages (CAM, DeNM) with an RSU	Slice creation and instantiation in MEC host, Data	T1.a, T5.b	Required Traffic flows from the vehicle to the RSU.	M16

	deployed on MEC host. A Video streaming service is deployed in the MEC host and delivered to the vehicle UE.	control connectivity between vehicle and infrastructure. (FR2, FR12)			
1.2	CIM (in the MEC host) receives and processes messages from the vehicle and the traffic simulator	Slice creation and third party Application Server Instantiation	T3.b,T2.h, T2.c, T2.d	Required traffic flows between the MEC and all involved entities (including traffic simulator input to CIM).	M18
1.2 plus	Integration of real radio equipment	Data plane connectivity among radio transport and cloud	T1.a, T1.d, T3.b,T2.h, T2.c, T2.d	Required E2E latency (radio protocol contribution between modem and SGi interface, transport contribution bt SGi interface and MEC processing time of algorithm	M19
1.3	The Extended-Sensing in the MEC host processes context data from CIM and compute decision (special message) to be notified to the vehicle.	Car Maker Application Server Instantiation and configuration in the car maker slice	T2.b, T2.d, T2.f, T3.b	Communication between VAs in MEC host Required latency and impact of Extended-Sensing algorithm	M20
1.4	In vehicles Integration + Backends (optional)	Cloud functionalities	T3.a, T2.i, T2.b, T2.d	End to End communication among all the service components	M25
1.5	Increase the amount of connected vehicle and slices (for different	SLA Monitoring. Service Scaling, Service Arbitration	T2.d, T2.f, T2.b,	Monitor assigned resources.	the M28

services, e.g. (FR3, FR4,
video FR5, FR6,
streaming). FR8, FR9)
The slice
instance
resources
should be
increased to
adapt to the
new
requirements.

The final integrated demo will be performed in a different step, after 1.5, at M28.

5.2 Entertainment PoC

5.2.1 Description

The entertainment PoCs will demonstrate the OLE (On-site live experience) and UHD (Ultra High-Definition) UCs, which are about providing the fan an immersive experience inside a sport venue. This is by means of a Spectator Mobile App that allows to follow the competition progress in real time and to interact with other additional services into the venue. The PoCs foresee the streaming of an UHD live feed simultaneously with several other UHD videos that can be consumed on-demand. In addition, the live feed will include DVR capabilities, allowing pause and rewind functionality to be able to watch past content in the live feed. This live feed will be enhanced with live metadata from the venue that can be shown on the app synchronized with the video that is being displayed. We refer to D1.1 for an in-depth description of the UC and to D1.2 for the reasons behind the selection of the OLE UC among all the UCs considered in D1.1.

The main objective with the demonstrations is to verify that the 5G-TRANSFORMER platform is capable of handling the deployment of a service which will transmit 4K UHD video content (3840x2160 @ 15-30 Mbit/s) simultaneously to several devices either on the same venue or on different venues, without requiring the vertical any knowledge about the infrastructure or the network services underneath. In this same direction, the objective is also to prove that backend can scale automatically and in real-time in order to handle the different load conditions.

The 5G approach also introduces one benefit which is aligned also with the contributions of the 5G-TRANSFORMER and that will be demonstrated in the entertainment PoCs: the capability of allocating resources near the fans. This is important for two reasons: first, because it reduces the probability of generating a bottleneck in the transport network and second, because it reduces the latency perceived by the fan. This latter reason is particularly important when the source of the content is local to the venue because reducing the latency for this content is critical to provide an immersive experience. Therefore, the Entertainment PoCs target all the functionalities related to this: MEC integration (FR12), Federation (FR1) and Vertical service distribution across multiple Data Centers (FR6). Particularly the Federation is relevant in this case since we foresee events including several venues where the network infrastructure belongs to different administrative domains. See Table 15 for further details about the functional requirements.

Finally, the immersive experience requires a seamless integration of all the vertical services involved in the venue independently of the owners of the services (i.e. the OLE service shall be able to interact with the service providing the statistics of the same sport event). In this project we refer to this as vertical service composition (FR2 in Table 15), and the Entertainment related PoCs also aim to demonstrate this feature.

In Figure 20 we show all the applications involved in the OLE and UHD UC. Notice that in both cases we also included internal names for the software package. This is to stress the impact of the project over the real product, since the goal in this project is to enhance the service with all the benefits of 5G.

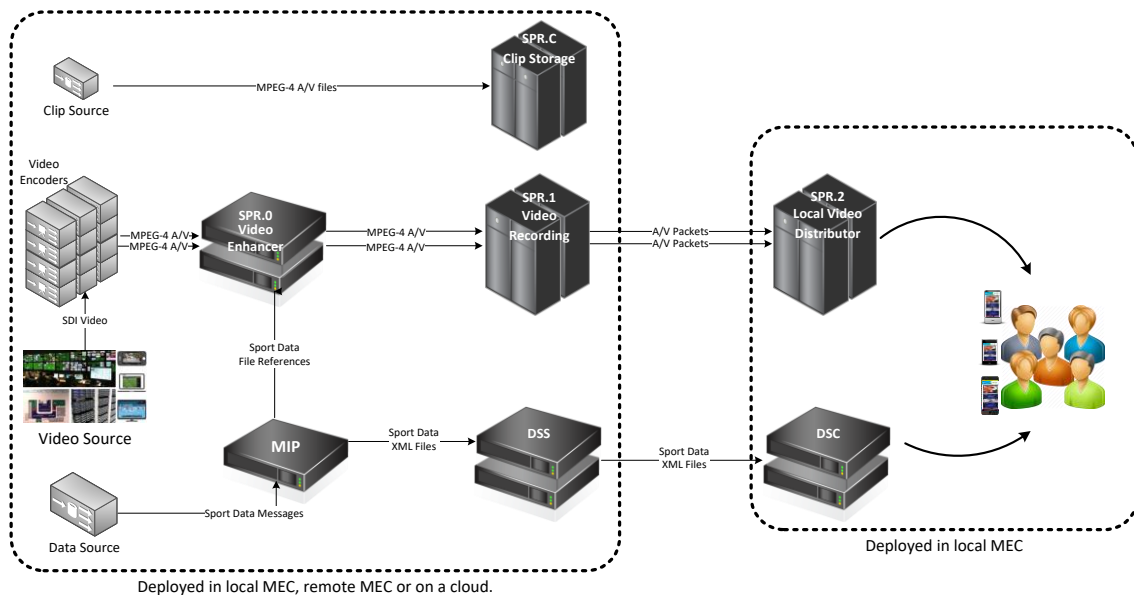

FIGURE 20: OLE AND UHD DESIGN

The components involved in the Entertainment PoCs are as follows:

- Video Enhancer (SPR.0): Receives the video streams from the cameras and injects the metadata inside the video. It should be located close to the cameras location.
- Video Recording (SPR.1): Records the videos received from the Video Enhancer and serves them to end users.
- Clip Storage (SPR.C): On-demand video storage. This component is a central storage of multi-quality videos that can be requested on-demand.
- Data Storage (DSS): Data storage for the app. This includes the metadata information shown on the app related to the event.
- Local Video Distributor (SPR.2): This component validates that the user is allowed to access the video and forward it from SPR.1 or SPR.C. It also has caching capabilities to optimize bandwidth consumption.
- Data Caching Service (DCS): This component forwards data files from the DSS component to the users. It includes caching capabilities to optimize bandwidth.

5.2.2 Initial planning of the PoC

Considering all the objectives already mentioned in the previous section we established an initial plan for the PoCs as reflected in Table 7.

TABLE 7: OLE AND UHD PoCs

PoC ID	Description	Functionalities to be tested	Required technologies	Verification	Month
2.1	A MEC platform is in place, and the platform instantiates the appropriate NSDs when the vertical service is requested. The spectator app requests an UHD video. The system provides the video feed to the app.	Network slice creation or instantiation. Data and control connectivity between the spectator app and the LVD. (FR12, FR3)	T1.a R, T1.d R, T2.a R, T2.b R, T3.b R, T4.a, T2.f R	Traffic flows from the system to the app.	M14
2.2	Connect the Video Distribution service with a PNF providing live stream.	Physical Network Function connectivity.	T1.a R, T1.d R, T2.b R, T2.a R, T2.g,	Communication between the VA and the live stream.	M16
2.3	Instantiate a separate vertical service (i.e providing video metadata), and connect it to the service instantiated in PoC 2.1	Connectivity between slices, Vertical Service composition. (FR2)	T1.a R, T1.d R, T2.b R, T2.a R, T2.c R	Traffic flows between all involved entities using the network slice.	M18
2.4	Interconnection of a secondary datacentre for backup source.	Data plane connectivity between different DC. (FR6)	T1.a R, T1.d R, T2.b R, T2.a R, T1.c	Monitoring, Traffic flow between DC.	M20
2.5	Instantiate the video service over multiple Administrative Domains.	Data plane connectivity between AD. (FR1)	T1.a R, T1.d R, T2.b R, T5.a R, T7.a R, T2.c R	Monitoring, Traffic flow between AD.	M22
2.6	Increase the amount of connected devices. The service instance resources should be increased to adapt to the new requirements.	Service Aware Monitoring. Service Scaling. (FR8, FR9, FR10, FR11, FR4)	T1.a R, T1.d R, T2.b R, T2.d R, T2e R	Monitor the assigned resources.	M24

5.3 E-Health PoC

5.3.1 Description

In the 5G-TRANSFORMER project we plan to further design and implement the “Heart Attack Emergency” use case previously defined in D1.1 [5]. In this use case, specific patients with high risk of having heart attacks have wearables like smart-watches or smart-shirts with special sensors to monitor heart bit rate, breathing values, position of the user, etc. Measurements of patients with normal values are transmitted to E-Health servers (eServers) in the Cloud using a best effort network slice (see Figure 21). The main goal of the eServer is to process all this information generated by the patients and to detect in advance issues that could lead to emergency situations. In those cases, the eServer has to confirm such problems requesting confirmation to the end user. If the emergency is confirmed, the eServer starts a process to respond to such emergency, invoking several functions:

- Move the patient’s device to an emergency network slice (see Figure 21). This network slice has the following characteristics:
 - High bandwidth, to allow high-resolution video calls between the different actors involved in this emergency, like paramedics, doctors at the hospital, etc.
 - Ultra-reliable low latency communication, to minimize the probability to have disruptions in the communication and, at the same time, to reduce the latency to collect information from the different actors involved in this emergency.
 - High mobility, in order to maintain all the communications of all ambulances while they are being deployed on the emergency location.
- Raise an alarm to the proper actors, like emergency stations. The eServer has to put in contact several actors, in order to facilitate the exchange of all data required during the emergency.
- Request the patient’s wearable to increase the rate of notifications of some parameters, depending on the issue detected.
- Create an instance of the eServer on the edge of the network, using MEC capabilities. All the information generated by the patient’s wearable will be transmitted to this instance instead of the previous one, to reduce the latency to process all the received information.

While the eServer deploys all the necessary mechanisms to respond to the emergency, the wearable could take actions to reduce the time of response, by searching for paramedics or doctors close to its area, using device-to-device technologies like WiFi Direct. If a paramedic/doctor is in the surroundings, the wearable may transmit its position after validating the other end to increase security. After this validation, this actor is included in the 5G emergency network slice and can be involved in all the exchange of information. Please notice that the device-to-device technology may help to reduce the time to detect paramedics/doctors in the neighbour of the patient, but it could be useful in areas with bad 5G coverage too.

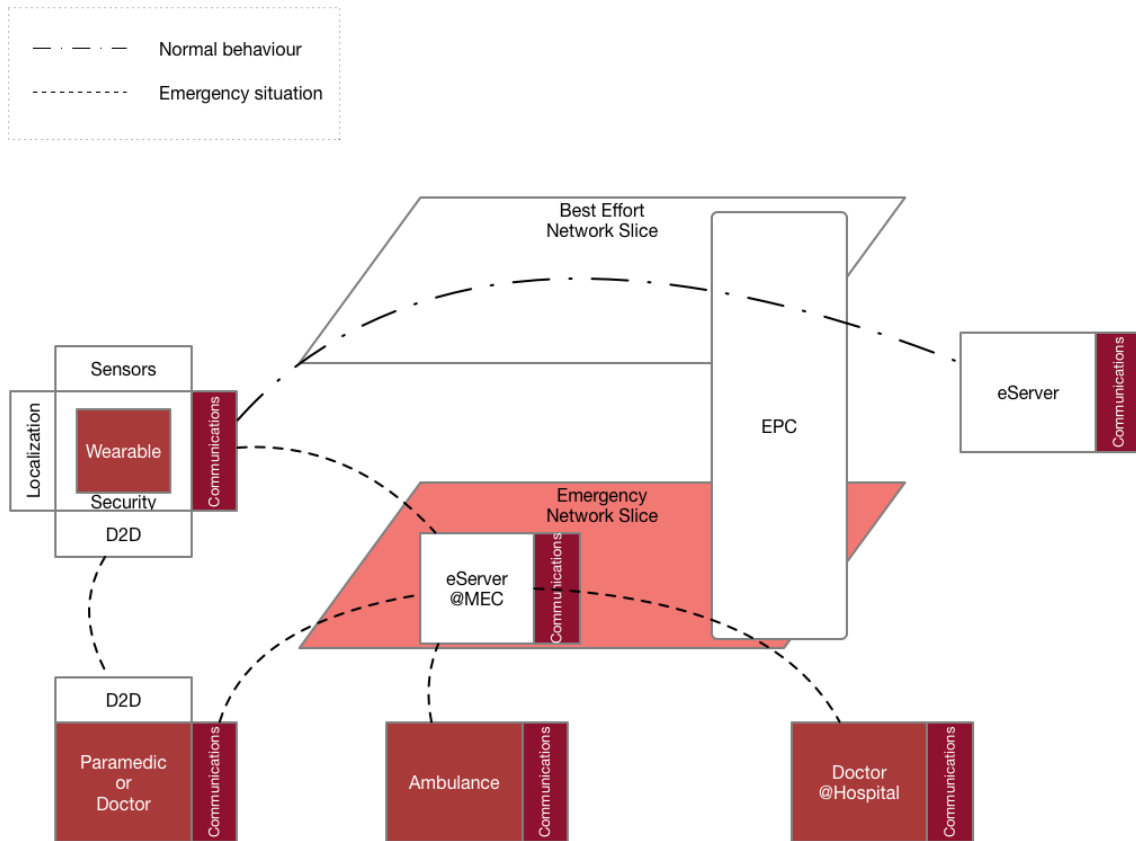

FIGURE 21: E-HEALTH FRAMEWORK

5.3.2 Initial planning of the PoCs

The following table summarizes all PoCs that will be implemented and deployed to fulfil the E-Health use case, that will be composed by the integration of these PoCs.

TABLE 8: E-HEALTH POCS

PoC ID	Description	Functionalities to be tested	Required technologies	Verification	Month
3.1	The wearable transmits information towards the eServer, which analyse the information. When an issue is detected, the eServer contacts the wearable to confirm or discards the alert.	Data and control connectivity between the wearable and the eServer, data analysis, alert confirmations. (FR1, FR3, FR6, FR10)	T1.a R, T1.d R, T4.a R, T4.d	Wearable off and on → alarm and cancel. Wearable off → alarm and confirmation.	M14
3.2	A MEC platform is deployed over the instantiated network slice.	MEC functionalities (FR8, FR12)	T3.b R	Required traffic flows between the MEC and all involved entities.	M18

3.3	After an alarm is confirmed, the wearable starts searching for paramedics in the neighbour area. If any paramedic is found, a communication is established.	Device-to-device communication.	T6.a R	Communication between patient and paramedic devices is established.	M22
3.4	After an alarm is confirmed, the eServer requests the configuration of a network slice among all involved entities is instantiated.	Network slice creation or instantiation. (FR4, FR5, FR9, FR11)	T2.a D, T2.b R, T2.c R, T5.b D, T7.a D.	Traffic flows between all involved entities using the network slice.	M25

All these PoCs will be integrated after PoC 3.4 in M28.

5.4 E-industry PoC

5.4.1 Description

The E-industry PoC has the aim to implement the Cloud Robotics (CR) service. Cloud robotics is a paradigm that leverages the powerful computation, storage and communication resources of modern data centers to enhance the capabilities of robots. The control functionalities are virtualised and moved into the cloud running on dedicated hosts or data centers (DC); Moving computation intensive task into the cloud it is possible to develop more intelligent and cheaper robotic systems; on the robots only the necessary sensors, actuators, and basic processing power are kept.

To allow the interaction among robots and the external environment in real-time, huge amounts of information will have to be transferred instantaneously. Thus, the mobile communication must satisfy specific requirements in terms of data rates, latency, reliability, density of connections, coverage, etc.

The communication requirements depend on the control functionalities to virtualize. For instance, as shown in Figure 22, if the control of the robotic area (“robotic area control”) is virtualized, a latency lower than 30 ms will be required. Otherwise, if also the control functionalities that reside in each Robot Controller - the task planner, trajectory planner and inverse kinematics - are moved into the cloud, very tight requirements, in terms of latency, must be satisfied (lower than 5ms)

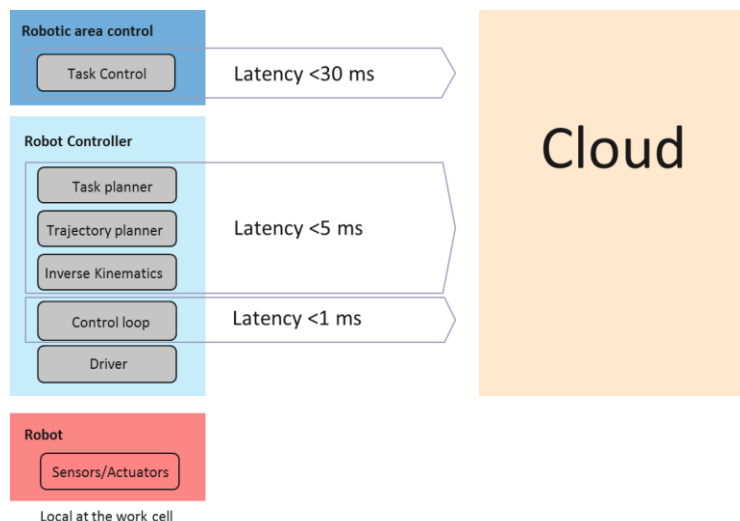

FIGURE 22: VIRTUALIZATION OF CONTROL IN THE CLOUD: LATENCY REQUIREMENTS

This PoC consists in the implementation of a Cloud Robotics service for factory automation where robots and production processes are remotely monitored and controlled in cloud, exploiting wireless connectivity (LTE/5G) to minimize infrastructure, optimize processes, and implement lean manufacturing.

In the presented scenario, robotic arms are put in place to load and unload goods from the mobile robots. An automated warehouse is simulated by a rotating platform, and an automated door is placed along the navigation tracks to show a flexible and optimized shuttling of materials between work cells in a plant.

The objective of the demonstrator is to verify that the system is able to allocate the suitable resources based on the specific service request to allow the interaction and coordination of multiple (fixed and mobile) robots controlled by remote distributed services, satisfying the tight latency requirements.

The demonstrator will show that, when a CR service request arrives, the required resources are correctly selected and configured. Latency will be measured to optimize the positioning of the vEPC and consequently identify the more suitable selection of the DC resources.

Different level of virtualization of the control functionality will be implemented to verify if the system is able to meet latency requirements in all possible real scenarios.

Moreover, fault on the transport domain will be simulated to verify the ability of the 5G-MTP platform to recovery from fault without impacting on the abstraction exposed to the 5G-SO.

5.4.2 Initial planning of the PoC

Table 9 summarizes the plan of expected releases of the E-industry PoCs.

TABLE 9: E-INDUSTRY PoCs

PoC ID	Description	Functionalities to be tested	Required technologies	Verification	Month
4.1	Preparatory experiment for CR service activation.	Traffic isolation. (FR8)	T2.a R, T2.b R	Verify the latency requirements and service isolation. This test will enable the network slice creation and instantiation in a next step.	M15
4.2	CR service activation	Data plane connectivity among Radio Transport and Cloud (FR3, FR7, FR6)	T1.a R, T1.d R, T4.a R, T6.b R	Check if latency requirements are met in different virtualization scenario and different (v)EPC location.	M20
4.3	Monitoring of failures on the transport domain	Monitoring of the transport domain for enabling recovery of degraded connectivity (FR9)		5G-MTP perform the monitoring for enabling recovery.	M26

5.5 MNO/MVNO: 5G Network as a Service use case

5.5.1 Description

Business-wise, studying the use case makes a lot of sense because virtualizing and offering networks as a service to MVNOs means cost savings, time-to-market decreasing, diversification of offers and more clients.

From a project point of view, whereas the vertical use cases are mostly characterized by non-functional aspects, i.e. KPIs like maximum latency or availability, the MVNO use case allows to focus more exclusively on the functional aspects.

MVNOs may not have very specific requirements in terms of KPIs, but simply ask for different sub-systems aaS (e.g. RANaaS, EPCaaS, Transport network aaS) to

interwork with some others. Among those some may be hosted by the same operator using IaaS.

Considering more precisely the vEPC use case, it reflects perfectly the concept of network slicing as defined in 3GPP TS 28.530 in terms of business service type. Actually, a VSP (MNO) can offer to its customers (MVNOs) LTE services in the form of a network slice as a service, including a set of specific exposed management functions. The latter ones can in turn provide their own services on top of the vEPC services: this UC matches with the B2B2X business type. Additionally, the vEPC UC permits exemplifying the type of 5G-VS customer MVNO with regard to the type VERTICAL. A user of the latter category consumes services while ignoring the underlying components (network slice, VNF) and resources used to support them.

Goal: Operate a 5G multi-access sliced network with different needs from MNO/MVNO.

Pre-conditions:

- Resources are available locally in the very dense area (eNodeBs, Wi-Fi APs, local DC...) but not activated
- A centralized operator's cloud should be available to host control VNFs
- Connectivity between on-site (radio resources, local DC) resources and cloud (centralized DC) resources
- Macro cell legacy mobile network already available

5.5.2 Initial planning of the PoC

Based on the description presented above, Table 10 presents a summary of the MNO/MVNO PoCs.

TABLE 10: MNO/MVNO PoCs

PoC ID	Description	Functionalities to be tested	Required technologies	Verification	Month
5.1	MNO requests the instantiation of a specific 5G network with local access to the infrastructure, in a split vEPC mode (CUPS)	Network slice template provision (SLA) (FR8)	T2.a R,	Vertical slicer order sent to 5GT-SO for network service instance creation	M15
5.2	End to end network slice set up and vEPC network service are instantiated, connected to local small cells and Wi-Fi APs. User Plane VNF and PNF are configured in the local area infrastructure. Control Plane VNF	Network slice/service instantiation. Multi-access CP/UP split. Access to local and central cloud. Interconnection with legacy MNO services (HSS at least) (FR1, FR2,	T1.a R, T1.d R, T2.a R, T2.b R, T2.f R, T2.c R.	VNFs are up and running	M20

	in the Central DC. FR3) The end to end slice provides the network service through local and central infrastructure and operator's services own infrastructure (HSS, ...)				
5.3	End-users are provided with multi connectivity (4G/5G/Wi-Fi), homogeneous QoE and unified authentication	Multi access, unified authentication	T2.b R, T4.a R, T2.f D	UE connectivity via Celular access and WiFi access toward Internet	M20
5.4	Direct access to local cloud allows end users to share and store their data locally with low delay and high bandwidth;	Local servers, applications (cache, CDN) (FR6, FR7)	T3.a R, T5.a D.	UE retrieve content cached in local Data Center	M23
5.5	Monitoring allows troubleshooting operations	Virtualized monitoring (FR9)		Traffic probe instantiated, monitoring dashboard	M25

All these PoCs will be integrated and shown in the final demo in M26.

5.6 PoCs Summary

5.6.1 Requirements

The following tables summarizes the requirements requested for the implementation of each use case.

The Table 11 shows the technological requirements to be demonstrated by each vertical, while Table 13 shows the functions required from the platform.

TABLE 11: TECHNOLOGY REQUIREMENTS PER USE CASE

Tech.	Automotive	Entertainment	e-Health	e-Industry	MNO/MVNO
T1.a	R	R	R	R	R
T1.d	R	R	R	R	R
T2.a	R	R	D	R	R
T2.b	R	R	R	R	R
T2.c	R	R	R		R
T2.d	R	R			D
T2.f	R	R			D
T2.g					D
T2.h	R	R			D
T2.i	R	R			R
T3.a	R	R			R

T3.b	R	R	R		
T4.a		DND	R	R	R
T4.b	DND	DND			
T4.c	DND	DND			
T4.d			D		
T5.a					D
T5.b	R		D		R
T6.a			R		
T6.b				R	
T7.a		DND	D		
T7.b		DND			

Legend: R - Required, D - Desirable, DND - Desirable but not demonstrated.

From the analysis of the technology requirements reported in Table 11, it is clear that the scenario is quite heterogeneous. There are some technologies requested only by one or two vertical and other not requested by anyone. Some technologies are available at one or more testbed other nowhere.

For a better analysis of the scenario technologies have been classified in 4 main categories keeping into account if they are required and available (see Table 5):

TABLE 12: TECHNOLOGIES CLASSIFIED IN 4 MAIN CATEGORIES

	Required	Not Required
Provided	T1.a, T1.d, T2.a, T2.b, T2.c, T2.f, T3.b, T4.a, T5.b, T6.a	
Not Provided	T2.d, T2.h, T2.i, T3.a, T6.b	T1.b, T1.c, T2.e, <u>T2.g</u> , <u>T4.b</u> , <u>T4.c</u> , <u>T4.d</u> , T4.e, T4.f, <u>T5.a</u> , <u>T7a</u> , <u>T7b</u> , T7.c

The following considerations derive from a deeper analysis:

- **Required & provided:** few of these technologies are requested by all verticals and will be demonstrated in all PoC
- **Not required & Not provided:** these technologies are not requested and not available, so it follows that they are not needed in the project. It should be noticed that the technologies 'desiderable' or 'desiderable but not demonstrated' (underlined in the table) are intrinsecly not essential for the use case implementation. Althought they have been considered for a complete analysis of the use cases requirements, they will not be further investigated.
- **Not required & provided:** all technologies provided by the integrated testbed are requested by any of the PoCs described in this document.
- **Required & not provided:** these technologies are required by one or more Verticals but are not provided. In this case, a deeper analysis should be done in order to understand if these technologies are essential for the implementation of the use cases that require them. A priority should be given to technologies required by more verticals. These considerations are based on the testbeds plans reported in Section 3. It should be noticed that at this moment the planning and availability of the novel technology components developed in

WP2, WP3 and WP4 is still not clear, therefore this table could be updated in the next deliverable versions.

Table 13 presents a summary of all functional requirements needed by the five use cases, that will be tested in any of the scheduled PoCs. It is important to highlight that all functional requirements listed in Annex II: Functional requirements for the 5G-TRANSFORMER platform are selected as required by at least two use cases.

TABLE 13: FUNCTIONAL REQUIREMENTS PER USE CASE

FR	Automotive	Entertainment	E-Health	E-Industry	MNO/MVNO
FR1		X	X		X
FR2	X	X			X
FR3	X	X	X	X	X
FR4	X	X	X		
FR5	X		X		
FR6	X	X	X	X	X
FR7				X	X
FR8	X	X	X	X	X
FR9	X	X	X		X
FR10		X	X		
FR11		X	X		
FR12	X	X	X		

5.6.2 Platform integration and PoC scheduling

The following plan shown in Table 14 provides an overview of all PoC releases scheduled during the project lifetime. As already mentioned, the idea is to follow an evolving approach where each PoC is built upon the previous ones and targets new technologies and features. This approach allows us focus each time in different aspects of the UC requirements and the platform, and at the same time to have a working PoC of the whole UC for the end of the project.

The diagram also indicates which are the planned releases for the 5G-TRANSFORMER platform. In this case the 5GT-VS and the 5GT-SO have two release cycles, the first ones are scheduled for the M16 and M18 respectively, while the second one is on M22 in both cases. The case of the 5GT-MTP requires further analysis since the implementation effort is tightly coupled to the drivers required for the different technologies present and its usage in the respective testbeds by the different PoCs. We also stress that the release plan marks the time when the features of the platform will be ready, and therefore it is expected an overlapping of development of the PoC using that feature and the implementation of that feature in the platform.

In general terms (the exact details of the platform development will be the subject of D3.2, D4.2 and D2.2) the first release of the 5GT-VS will be focused on the instantiation, and termination of vertical services. This includes a working prototype of the Network Slice Manager to support NSI (NSSIs will be subject of the second release), the module to perform the translation, SLA verification and basic drivers to connect to different service orchestrators. The second release for this component will include the integration of the monitoring platform, the vertical service arbitration capabilities and will extend the translation capabilities and the integration with the 5GT-SO.

TABLE 14: POCs AND DEMOS SCHEDULING

Use cases	2018												2019								
	A	M	J	J	A	S	O	N	D	J	F	M	A	M	J	J	A	S	O	N	
	11	12	13	14	15	16	17	18	19	20	21	22	23	24	25	26	27	28	29	30	
Automotive	1.1					1.2		1.2 plus		1.3		1.4		1.5		demo					
Entertainment	2.1			2.2			2.3		2.4		2.5		2.6		demo						
E-Health	3.1			3.2			3.3				3.4			demo							
E-Industry	4.1			4.2				4.3				demo									
MNO/MVNO	5.1				5.2/5.3				5.4		5.5			demo							
5GT-VS Releases						1						2									
5GT-SO Releases								1					2								

The 5GT-SO uses Cloudify as the reference implementation which already supports most of the orchestration capabilities required by the PoCs (we refer to D1.2 for further details about this). The objective for the first release is to develop the plugins required to connect different cloud environments, provide full support for the MEC integration and support the 5GT-MTP abstraction. In the second release, the focus will be set on: integrating the federation related modules and extend the drivers for the interaction with the 5GT-MTP to provide and end to end. The deployment of the monitoring platform of the 5G-TRANSFORMER is also scheduled for this latter release.

As can be seen this platform release plan is aligned with the schedule for vertical PoCs, and therefore together with the testbed integration plan detailed in the next section settles the bases for the vertical testbed integration. Further details will be

provided in future deliverables with a finer grained definition of the software modules required and more precise dates for the development of the functionalities and the PoCs.

6 Initial integration plan

This section proposes an initial planning to integrate the different trial sites of the 5G-TRANSFORMER project, in order to provide a homogeneous and integrated testbed to execute all proof-of-concepts.

In Section 3 we have presented all trial sites of the project, focusing on the technologies and services available in each trial site. One important point is the technologies available to do the inter site connections, as well as to allow external experimenters to run their tests on the integrated platform. In all the four sites, VPNs are supported, so this will be the main protocol to interconnect sites. Another interesting result after analyzing the technologies available in all sites is the fact of having, among all sites, the following technologies and services:

- Technologies of access and core networks.
- The possibility to instantiate end-to-end network slices.
- NFV for 5G networks.
- SDN/NFV-based management and orchestration (MANO) 5G Networks.
- Virtual CDN service reconfiguration.
- Multi-access Edge Computing support.
- Encryption and other privacy-enhancing technologies.
- Platforms for mission critical communications.
- Device-to-device technologies.

The inter-testbeds measurement results analyzed in Section 4 shows the viability of interconnecting the different sites through the Internet. Depending on the requirements imposed by each use case, it would be feasible to deploy them in different sites, so the connection between these sites will depend on the required throughput and delay for both the control and data planes.

Based on the technologies and functional requirements of the PoCs expressed by all use cases and described in Section 5, it is expected that different sites have to be interconnected to provide a unified and integrated testbed. Although at this stage there are still discussions to define where the different PoCs will be implemented, it is clear that services like federation require this interconnection.

After analyzing the technologies available in each site, the throughput and delay performance between all sites, and the requirements of all proof-of-concepts, we propose to integrate all sites following the design shown in Figure 23. This design is a first step to start defining the integrated testbed that will be used in the 5G-TRANSFORMER project, and it will be refined in next deliverables.

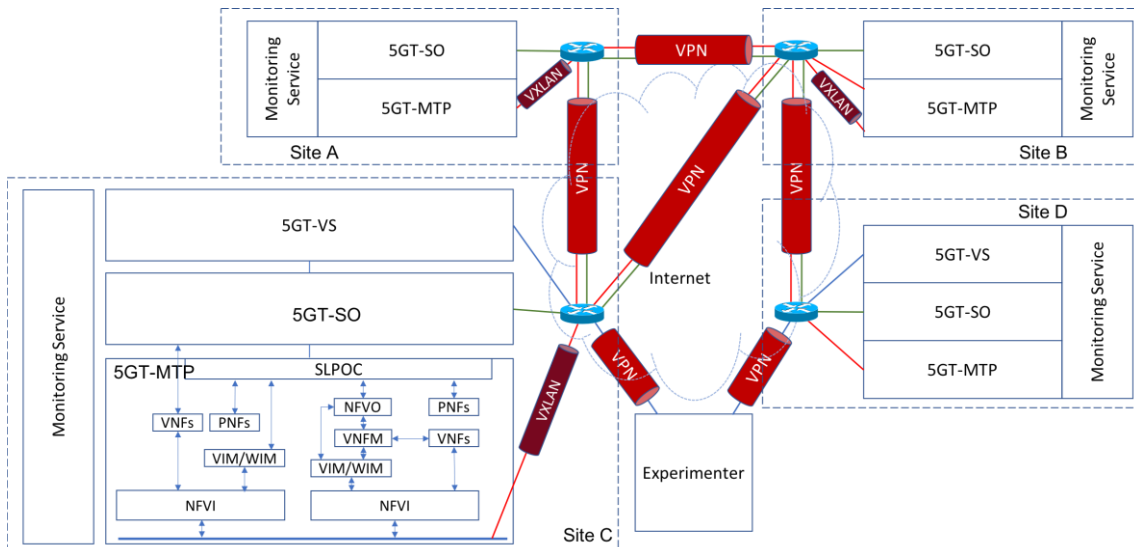

FIGURE 23: 5G-TRANSFORMER INTEGRATED TESTBED. INITIAL PLAN

As already stated, when two sites have to be interconnected, one of its sides will provide Virtual Private Network (VPN) credentials to the other end, which, in turn, will use these credentials to establish a VPN tunnel providing layer 3 connectivity, which is the service provided in all trial sites. For example, in Figure 23, sites A and C are interconnected using a VPN where, for example, site C is providing credentials to site A. It is important to notice that the VPN is bidirectional, so it does not matter which end is the server or the client of the VPN. Depending on the different PoCs, that will be further defined in next deliverables, the technologies available in each site, and the network parameters of all links, it may not be necessary to interconnect all sites in a full mesh. Using Figure 23 as an example, if sites A and B have a very high delay, or very low throughput, a VPN connecting both sides will not be necessary. As previously mentioned, Figure 23 presents a proposal, and the final network topology will be decided in next deliverables.

Site C in Figure 23 shows a more detailed view about a particular site. As described in Section 2, the 5G-TRANSFORMER architecture includes four main building blocks:

- 5GT-VS or Vertical Slicer, used by verticals to define their services. This functional block provides vertical service blueprints to the verticals, so they can define their services and upload them to the vertical service. In Figure 23 we include a functional box called “Experimenter”, that shows the vertical connected to a particular 5GT-VS. For security purposes, experimenters need to establish a VPN with the site they want to upload, run and monitor their experiments. Because the main function of the 5GT-VS is to adapt vertical services to network services, this building block may not be necessary to be deployed in all sites. This is the reason site A and B do not provide a 5GT-VS, but it is available in sites C and D (strictly speaking, only one 5GT-VS is necessary, but we can include more in order to test different configurations). The interface between the 5GT-VS and the Experimenter can be used to monitor the running experiments too.
- 5GT-SO or Service Orchestrator, provides end-to-end orchestration of the requested network service received from the 5GT-VS, by using the local resources or by requesting resources to other administrative domains (known

as federation) contacting their 5GT-SOs using the So-So interface. In our proposal to integrate the different sites, shown in Figure 23, we use the green network to provide connectivity between the 5GT-SO of the corresponding sites. We assume at this phase that all sites will deploy the 5GT-SO, but it may not be necessary to connect all 5GT-SOs. For example, sites A and B are not connected, which means that they do not need the So-So interface. This will depend on the PoCs that will be executed in each site.

- 5GT-MTP or Mobile Transport and Computing Platform is responsible for the instantiation of VNFs over the Network Function Virtualization (NFVI) under its control, and for orchestration of resources in some technology domains. The 5GT-MTP presents a Single Logical Point of Contact (SLPOC) to the 5GT-SO to request resource allocation. The 5GT-SO may directly contact local VNFs for management purposes. In case federation between different sites is used, 5GT-MTPs at those sites must share the same data plane. We propose, as an initial design, to define the red network shown in Figure 23 to interconnect the 5GT-MTPs between different sites. The data plane will be described in detail next.
- 5GT Monitoring Service, responsible to collect monitoring data related to different entities (e.g. compute and network nodes in the NFVI, VMs, applications running in the VNFs) and elaborate them through aggregation and computation algorithms. Raw data are collected using agents dedicated to the specific technology or data source and their processing generates monitoring metrics that are consumed at the local 5GT-SO or 5GT-VS to take internal decisions (e.g. for scaling an NFV network service) or to provide monitoring information to the verticals (e.g. about the application performance of a vertical service). The exchange of monitoring data among different sites should be mediated through the 5GT-SO, through the So-So interface.

6.1.1 Data plane interconnection

In the process of establishing a VPN tunnel, the server of the VPN will push to the client all IP routes to reach devices at its end, so both ends are connected at the IP (3) level. Devices at both end of the VPN tunnel have to be properly configured to reach devices at the other end, because they are in different IP subnetworks. Sometimes, experiments require all or some devices to be connected to the same IP subnetwork. Because this is expected to happen in some PoCs, where VNFs may be deployed in different sites, we have decided to include in the data plane interconnection the possibility to use Virtual eXtensible LAN (VXLAN) [25], which allows to overlay virtualised Layer 2 networks over Layer 3. The VXLAN configuration has to be done at each site that plans to provide this type of network to the integrated testbed.

Figure 23 shows that, in our example, sites A, B and C provide this type of network, so all VNFs connected to this network will share the same broadcast domain. Implementing VXLAN is not mandatory, so some sites may not deploy VXLAN in the data plane. For example, Figure 23 shows a site D where VXLANs are not available at the data plane. This site cannot deploy VNFs connected at the same subnetwork as VNFs at site A or C, but because site B implements two red networks, one with VXLAN and another one without VXLAN, the orchestrator may instantiate VNFs at B that can be connected with the VNF at D. Figure 24 shows a schematic view of these two networks.

There is a trade-off between complexity and flexibility, and we have decided to be as flexible as possible, in case a PoC requires this kind of configuration with VNFs at different sites sharing the same layer 2 network. Furthermore, it is important to notice that it is possible to start the integration without VXLANs and include them only when necessary.

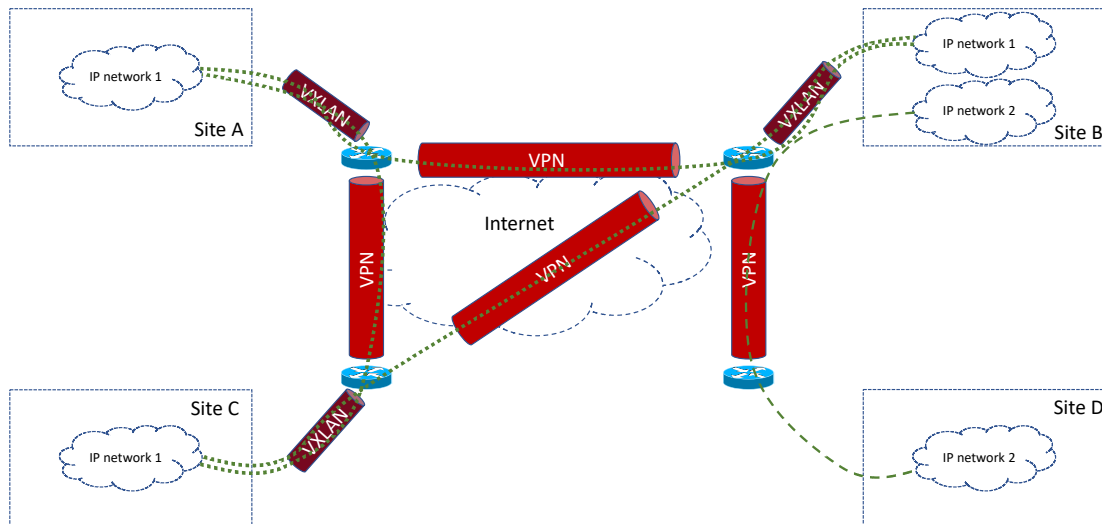

FIGURE 24: DATA PLANE WITH LAYER 2 AND LAYER 3 NETWORKS

The IP addressing has to be carefully defined in order to allow a flexible deployment of all PoCs in the whole integrated testbed. This will be presented in next deliverables.

It is important to notice that both the data and the control planes could share the VPN tunnels. We do not foresee any problem regarding this particular point, but it would be possible to manage each traffic flow at routers available at each site to prioritize the most important traffic, if necessary. The suitability of this decision will be validated during the first PoCs, and it will be reported in next deliverables.

6.1.2 Management of the integrated testbed

An integrated testbed has to be robust enough to allow the deployment of small tests but also to distribute trials among all sites composing the testbed. It is also advisable to provide a testbed with the required tools to manage and log the performance at any moment, so to have extra information about the status of the testbed when analyzing the result of performed trials. These tools should be flexible enough to also define thresholds to generate alarms to the system administrator who is managing the testbed.

There are several tools that can be used for this purpose. One of the most popular tool to manage networks and devices is Nagios [28], which allows to install core components to provide the basic functionalities like monitoring, logging, alerting, reporting, etc. Nagios can be extended by means of plugins that give extra control to system administrator. Other solutions, like Check_MK [29] are based on Nagios, and presents an open source and professional version with extended capabilities. There are other choices with a reduced set of features, like SmokePing [30], which is focused on the monitorization of active links, generating alarms when an issue is detected.

It is clear that, at least, a tool like SmokePing is highly recommended in our integrated testbed. This is necessary to detect underperforming links and to react as soon as possible to minimize the consequences. It is advisable to have better tools like Check_MK, but the decision of the management tool will be analysed in detail in WP5, and reported in the next deliverable.

7 Conclusions

This deliverable has presented a detailed view of the different trial sites provided by the partners of the project. We have elaborated a list with the main technologies required for all use cases, and it is used to summarize all components available in each trial site. One important result presented in this document is a table showing all technologies that will be available in the future integrated testbed to be used in the Proof-of-Concepts (PoCs).

Furthermore, in order to analyze the expected performance between the different sites, in terms of throughput and end-to-end delay, we have conducted several campaigns to measure these parameters. These results, together with other information like the trial sites supporting the different use cases, will be used in the next deliverable to decide the actual connection between sites. The first results, showing asymmetric links between ARNO and all the other three trial sites, indicate that it is necessary to analyze the connectivity issues with this site.

This deliverable presents an initial planning of the PoCs per use case: Automotive, Entertainment, E-Health, E-Industry and MNO/MVNO PoCs. All PoCs include the functional requirements, the technologies required to deploy them and how to verify that the PoC has been finalized. We have detected some gaps related with the technologies available in the trial sites compared with the technologies required by some PoCs, namely NFV service scaling procedures, reference monitors and authentication enablers to regulate network access control, cross NFV_NS data base, vertical specific VNF and fog/edge/cloud computing to implement multi-layer monitoring and control. It is recommended to further progress on the definition of the potentially affected PoCs and to check the possibility to provide the missing technologies and services in the final integrated testbed. Besides missing technologies, all functionalities provided by the 5G-TRANSFORMER blocks, listed in Annex II, will be used by, at least, by two use cases, guaranteeing the proper validation of these functional requirements. . Furthermore, in terms of vertical platform integration we have shown how our PoCs schedule coarsely matches the 5G-TRANSFORMER platform releases.

With all this information, we have defined an initial plan to interconnect all trial sites. Although the definitive configuration has to be completely defined in next deliverables, we propose a generic schema where a given site has to have connectivity with other sites by means of a point-to-point layer 3 VPN, in order to interconnect their 5GT-MTP and 5GT-SO functional blocks. Apart from this, a site may include a VXLAN to provide layer 2 access to its data plane and a 5GT-VS. If a site implements a 5GT-VS, then it has to provide access to this service by means of a layer 3 VPN.

In next deliverables we will specify where the different PoCs will be deployed, what will be provided by each site to the global testbed (5GT-VS and/or VXLAN) and a refined plan to integrate the 5GT-MTP, 5GT-SO and 5GT-VS functional elements.

8 References

- [1] NGMN Alliance, "Description of network slicing concept," NGMN 5G P, vol. 1, 2016.
- [2] 5G-TRANSFORMER, D1.2, 5G-TRANSFORMER initial system design, May 2018.
- [3] B. Chatras, U. S. Tsang Kwong and N. Bihannic, "NFV enabling network slicing for 5G," 2017 20th Conference on Innovations in Clouds, Internet and Networks (ICIN), Paris, 2017, pp. 219-225.
- [4] TeleManagement Forum. "TeleManagement Forum Information Framework (SID): GB922_Addendum_4SO_Service_Overview_R9-5_v9-7".
- [5] 5G-TRANSFORMER, D1.1, Report on vertical requirements and use cases, 2017.
- [6] 5G-TRANSFORMER, D2.1, Definition of the Mobile Transport and Computing Platform, 2018.
- [7] 5G-TRANSFORMER, D4.1, Definition of service orchestration and federation algorithms, service monitoring algorithms, 2018.
- [8] 5G-TRANSFORMER, D3.1, Definition of vertical service descriptors and SO NBI, 2018.
- [9] 3GPP TR28.801, V15.0.0, Telecommunication management; Study on management and orchestration of network slicing for next generation network, 2017.
- [10] ETSI GS NFV-IFA-013, V2.4.1, Management and Orchestration; Os-Ma-Nfvo reference point - Interface and Information Model Specification, 2018.
- [11] Xi Li et.al., Service Orchestration and Federation for Verticals, 1st Workshop on Control and management of Vertical slicing including the Edge and Fog Systems (COMPASS), Barcelona, IEEE, 2018.
- [12] ETSI GS NFV-MAN 001, V1.1.1, Management and Orchestration, 2014.
- [13] ETSI GS NFV-IFA-005, Management and Orchestration; Or-Vi reference point - Interface and Information Model Specification", v2.4.1, 2018.
- [14] ETSI GS NFV-IFA 006, V2.3.1, Management and Orchestration; Vi-Vnfm reference point - Interface and Information Model Specification, 2017.
- [15] ETSI GS NFV-IFA 008, "Ve-Vnfm reference point - Interface and Information Model Specification." V2.4.1, Release 2, Feb. 2018.
- [16] P. Iovanna et.al., 5G Mobile Transport and Computing Platform for verticals, 1st Workshop on Control and management of Vertical slicing including the Edge and Fog Systems (COMPASS), Barcelona, IEEE, 2018.
- [17] ETSI MEC, [Online], <http://www.etsi.org/technologies-clusters/technologies/multi-access-edge-computing>
- [18] ETSI GS NFV-INF 003, Infrastructure; Compute Domain", v1.1.1, 2014.
- [19] ETSI GS NFV-INF 004, Infrastructure; Hypervisor Domain", v1.1.1, 2015.
- [20] ETSI GS NFV-INF 005, Infrastructure: Network Domain, V1.1.1, 2014.
- [21] ETSI GS NFV-IFA 028, Management and Orchestration; Report on architecture options to support multiple administrative domains", v3.1.1, 2018.
- [22] ETSI GS NFV-IFA 010, Management and Orchestration; Functional requirements specification", v2.4.1, 2018.
- [23] ETSI GR NFV 001, "Network Functions Virtualisation (NFV); Use Cases", v1.2.1, 2017.
- [24] ETSI GS NFV-MAN 001, V1.1.1, Management and Orchestration, 2014.
- [25] Mahalingam, M., Dutt, D., Duda, K., Agarwal, P., Kreeger, L., Sridhar, T., & Wright, C. (2014). Virtual extensible local area network (VXLAN): A framework for overlaying virtualized layer 2 networks over layer 3 networks. Internet Engineering Task Force (IETF). RFC 7348. August, 2014.

-
- [26] NFGI, <https://standards.ieee.org/develop/wg/NGFI.html>.
 - [27] nFAPI, https://scf.io/en/documents/082_-_nFAPI_and_FAPI_specifications.php
 - [28] Nagios, <https://www.nagios.org/> (last access: May 2018).
 - [29] Check_MK, https://mathias-kettner.com/check_mk.html (last access: May 2018).
 - [30] SmokePing, <https://oss.oetiker.ch/smokeping/> (last access: May 2018).
 - [31] Iperf, <https://iperf.fr/> (last access: May 2018).
 - [32] 3GPP TR 36.912, Feasibility study for Further Advancements for E-UTRA (LTE-Advanced). March 2017.

9 Annex I: List with the technologies required in 5G

The following provides a list with the group of technologies required in 5G and that could be necessary in some Proof-of-Concepts. We have departed from a list generated by the IA 5G-PPP Trials Working Group, enhancing it with other technologies we have detected that could be used by some verticals. The rationale behind generating this list is to have a common understanding about all technologies, so the verticals in the 5G-TRANSFORMER project can use it to detect the requirements for their Proof-of-Concepts as well as to generate a list with the technologies available at the trial sites.

Technologies

1. Heterogeneous Network

- a. HetNet Architecture:5G,LTE-A,WIFI interworking capabilities
- b. Heterogeneous network technology and its interworking to address TR2incl. Interoperability with Tetra / TetraPol / P25 environment
- c. Heterogeneous network interworking on the with existing in-factory networks
- d. Core Network

2. Targeted Virtual Networks (VNF)

- a. End-to-End Network Slicing with predictable performance isolation
- b. Network Functions Virtualization (NFV) of 5G Networks
- c. SDN/NFV-based Management and Orchestration (MANO) 5G Networks across multiple administrative network domains.
- d. NFV service scaling procedures
- e. Virtual CDN service reconfiguration mechanisms on demand
- f. End-to-end control of reliability & performance (Bluetooth, WIFI, RAN, LTE, Core)
- g. Reference monitors and authentication enablers to regulate NW access control.
- h. Cross NFV_NS Data Base
- i. Vertical Specific VNF

3. Cloud and Edge computing functions (CLD)

- a. Fog/edge/cloud computing to implement multi-layer monitoring & control
- b. Multi-access Edge Computing

4. Enhanced Privacy and Security Techniques (PRIV)

- a. Encryption and other Privacy-enhancing technologies
- b. User/vehicle Privacy protection systems
- c. Security-enhancing technologies (embedded SIM, PUFs)
- d. Trust management for citizens, patient, families, care givers, etc
- e. Distributed ledger to record transactions in a verifiable and permanent way
- f. Block chain

5. Broadcast and Streaming Functions (eMBB)

- a. Efficient multicast and caching
- b. platforms for mission critical (group) communications (voice, data, video)

6. IoT Enabler Functions (mMTC)

- a. Enhanced Device-to-Device (D2D) communication technology
- b. Efficient ultra-low latency scheduling of small data packets (few bytes payload)

7. Localization Techniques (LOC)

- a. Network based location services
- b. 5G-based active localization technology + integration with other technologies
- c. 5G-based device-free localization technologies (passive radar)

10 Annex II: Functional requirements for the 5G-TRANSFORMER platform

In Table 15 we enumerate the set of functional requirements identified for the 5G-TRANSFORMER platform. This table aims to simplify the description of the PoCs of the project and to work as input to establish the platform release plan to be detailed in future deliverables.

TABLE 15: 5G-TRANSFORMER FUNCTIONAL REQUIREMENTS

Id	Name	Description	Architectural components involved
FR1.	Federation	Seamlessly deploy a vertical service using resources or network services belonging to different administrative domains as described in [2].	5GT-SO
FR2.	Vertical Service Composition.	Instantiate vertical services that use the instances of other vertical services as described in [2].	5GT-VS
FR3.	Lifecycle management of vertical service.	Control the lifecycle of the vertical service.	5GT-VS
FR4.	Dynamic Changes of vertical service.	Give the VNFs/VAs composing the vertical service the possibility of scaling up/down the resources assigned to the service based on internal triggers.	5GT-VS
FR5.	Arbitration.	Automatic mechanism to act on resource outage based on vertical service priorities, etc.	5GT-VS
FR6.	Vertical service distribution across multiple Data Centers.	Integrate the resources and network services instantiated over multiple data centers.	5GT-MTP
FR7.	Lifecycle management of network slices.	Give the verticals the possibility of controlling the network slices associated to their vertical services.	5GT-VS
FR8.	SLA definition.	Define and enforce service level agreements.	5GT-VS, 5GT-SO
FR9.	Monitoring	Provide the verticals the capability of monitoring all the	5GT-VS, 5GT-SO, 5GT-MTP

	monitoring items associated to the vertical service.	
FR10. Orchestration-Placement	Provide the verticals the possibility of defining rules or algorithms that could influence the placement decisions.	5GT-VS, 5GT-SO
FR11. Orchestration-Scaling	Provide the verticals the possibility of defining rules or algorithms that could influence the scaling decisions.	5GT-VS, 5GT-SO
FR12. MEC Integration	Seamlessly integrate the MEC platform.	5GT-VS, 5GT-SO, 5GT-MTP

11 Annex III: C-plane latency analysis

In Table 16 the entire delay needed for the attachment process is evaluated except for the transfer delay between the eNodeB and the MME.

TABLE 16: C-PLANE LATENCY ANALYSIS FROM 3GPP PERSPECTIVE.

Component	Description	Minimum [ms]	Average [ms]
1	Average delay due to RACH scheduling period	0.5	2.5
2	RACH Preamble	1	1
3-4	Preamble detection and transmission of RA response (Time between the end RACH transmission and UE's reception of scheduling grant and timing adjustment)	3	5
5	UE Processing Delay (decoding of scheduling grant, timing alignment and C-RNTI assignment + L1 encoding of RRC Connection Request)	5	5
6	Transmission of RRC Connection Request	1	1
7	Processing delay in eNB (L2 and RRC)	4	4
8	Transmission of RRC Connection Set-up (and UL grant)	1	1
9	Processing delay in the UE (L2 and RRC)	15	15
10	Transmission of RRC Connection Set-up complete (including NAS Service Request)	1	1
11	Processing delay in eNB (Uu -> S1-C)	4	4
12	S1-C Transfer delay	T_S1	T_S1
13	MME Processing Delay (including UE context retrieval of 10ms)	15	15
14	S1-C Transfer delay	T_S1	T_S1
15	Processing delay in eNB (S1-C -> Uu)	4	4
16	Transmission of RRC Security Mode Command and Connection Reconfiguration (+TTI alignment)	1.5	1.5
17	Processing delay in UE (L2 and RRC)	20	20
	Total delay [ms]	76	80