



H2020 5G-TRANSFORMER Project  
Grant No. 761536

# First periodic report of the project

## Abstract

This report constitutes the nonfinancial part of the Periodic Report to be delivered two months after the end of the period (M15).

## Document properties

<b>Document number</b>	D7.3
<b>Document title</b>	First periodic report of the project
<b>Document responsible</b>	Carlos J. Bernardos (UC3M)
<b>Document editor</b>	Carlos J. Bernardos (UC3M)
<b>Editorial team</b>	Carlos J. Bernardos (UC3M), Thouraya Toukabri (ORANGE), Paola Iovanna (TEI), Thomas Deiß (NOK-N), Xi Li (NECLE), Juan Brenes (ATOS), Josep Mangués-Bafalluy (CTTC), Giulio Bottari (TEI)
<b>Target dissemination level</b>	Public
<b>Status of the document</b>	Final
<b>Version</b>	1

## Production properties

<b>Reviewers</b>	Thomas Deiß (NOK-N), Antonio de la Oliva (UC3M)
------------------	-------------------------------------------------

This document has been produced in the context of the 5G-TRANSFORMER Project. The research leading to these results has received funding from the European Community's H2020 Programme under grant agreement N° H2020-761536.

All information in this document is provided “as is” and no guarantee or warranty is given that the information is fit for any particular purpose. The user thereof uses the information at its sole risk and liability.

For the avoidance of all doubts, the European Commission has no liability in respect of this document, which is merely representing the authors view.

## Table of Contents

List of Figures .....	4
List of Tables .....	5
List of Acronyms .....	6
Executive Summary .....	9
1 Publishable Summary .....	10
1.1 Summary of the context and overall objectives of the Project .....	10
1.1.1 Project context .....	10
1.1.2 Project Objectives .....	11
1.2 Work performed from the beginning of the project to the end of the period covered by the report and main results achieved so far .....	11
1.3 Progress beyond the state of the art and expected potential impact (including the socio-economic impact and the wider societal implications of the project so far) 12	12
2 Patents .....	14
3 Dissemination activities .....	15
4 Explanation of the work carried out by beneficiaries and Overview of the progress .....	20
4.1 Objectives .....	20
4.2 Explanation of the work carried per WP .....	29
4.2.1 WP1 .....	29
4.2.2 WP2 .....	43
4.2.3 WP3 .....	47
4.2.4 WP4 .....	55
4.2.5 WP5 .....	64
4.2.6 WP6 .....	76
4.2.7 WP7 .....	85
4.3 Deliverables .....	88
4.4 Milestones .....	89
4.5 Exploitable Results .....	89
4.5.1 Exploitation on commercial products and PoC developed internally to the companies .....	89
4.5.2 Exploitation on the realization of common platform among the 5G- TRANSFORMER partners by means of testbed and demos .....	90
4.5.3 Exploitation on standards .....	91
4.6 Impact .....	92
4.6.1 Progress towards the 5G-PPP Key Performance Indicators .....	96
5 Update of the plan for exploitation and dissemination of result .....	99
6 Deviations from Annex 1 .....	100
6.1 Tasks .....	100
6.2 Use of resources .....	100
7 References .....	101

## List of Figures

Figure 1: 5G-TRANSFORMER system architecture.....	12
Figure 2: 5TONIC Infrastructure.....	12
Figure 3: 5G-TRANSFORMER stakeholders mapping with the system architecture .....	39
Figure 4: 5G-TRANSFORMER system architecture.....	41
Figure 5: Hierarchy of monitoring services in 5G-TRANSFORMER architecture .....	42
Figure 6: 5GT-MTP ARCHITECTURE .....	45
Figure 7: The vertical slicer architecture.....	52
Figure 8: Reference points of the 5GT-VS NBI.....	53
Figure 9: Workflow for VSD preparation.....	54
Figure 10: 5GT-SO System Architecture - Building blocks and their interactions.....	56
Figure 11: Functional architecture of the 5GT-SO monitoring platform.....	60
Figure 12: Federation as a domain unified by mutual trust [19] .....	62
Figure 13: 5GT-SO EBI/WBI reference points .....	63
Figure 14: 5TONIC Infrastructure (Partners involved: UC3M, Ericsson, NECLE) .....	65
Figure 15: CTTC Testbed Infrastructure (Partners Involved: CTTC).....	65
Figure 16: EURECOM Infrastructure (Partners Involved: EURECOM) .....	66
Figure 17: EURECOM MEC platform (Partners involved: EURECOM).....	66
Figure 18: ARNO Access (Partners involved: SSSA) .....	67
Figure 19: ARNO Infrastructure (Partners involved: SSSA).....	67
Figure 20: Testbed integration plan (UC3M, SSSA, ERICSSON, NECLE, EURECOM).....	69
Figure 21: PoC Scheduling .....	75
Figure 22: 5G-TRANSFORMER Communication, Dissemination, and Exploitation Plan (CoDEP) .....	79
Figure 23: Mobile World Congress 2018 5G-TRANSFORMER Leaflet .....	81

## List of Tables

Table 1: Exhaustive list of 5G-TRANSFORMER use cases .....	31
Table 2: KPIs definition .....	32
Table 3: Use case application scenarios and their associated KPIs .....	36
Table 4: KPIs characterization and relevance .....	37
Table 5: Mapping between 5G-TRANSFORMER and 5G-PPP KPIs.....	38
Table 6: 5G-TRANSFORMER services.....	40
Table 7: VSB for latency probe .....	48
Table 8: Query VS Blueprints messages.....	53
Table 9: Integrated Testbed Technologies (UC3M, SSSA, ERICSSON, NECLE, EURECOM and CTTC) .....	67
Table 10: 5G-TRANSFORMER Functional requirements (Atos, UC3M, CRF, BCOM, NOK-N, SAMUR, TEI).....	69
Table 11: 5G-TRANSFORMER PoCs .....	71
Table 12: Communication articles .....	84
Table 13: Communication presentation and lectures.....	84
Table 14: Activity within 5G PPP CSA WGs .....	84
Table 15: 5G-TRANSFORMER and 5G PPP CSA WGs .....	87
Table 16: Mapping between building blocks of the project the relevant partners' PoCs, Products, Services and Solutions.....	90
Table 17: Plan for demonstration and testbed .....	90
Table 18: 5G-TRANSFORMER contributions to standards .....	91
Table 19: 5G-TRANSFORMER KPIs .....	96

## List of Acronyms

Acronym	Description
5GC	5G Core
5GT-MTP	Mobile Transport and Computing Platform
5GT-SO	Service Orchestrator
5GT-VS	Vertical Slicer
AAA	Authentication, Authorization, Accounting
AD	Administrative Domain
AN	Access Network
API	Application Programming Interface
AppD	Application Descriptor
BSS	Business Support System
CAM	Cooperative Awareness Messages
CAT	Catalogue
CIM	Cooperative Information Manager
CN	Core Network
CR	Cloud Robotics
CSMF	Communication Service Management Function
CU	Central Unit
DB	Database
DC	Datacenter
DF	Deployment Flavor
DoA	Definition of Action
DU	Distributed Unit
E2E	End to end
EBI	Eastbound Interface
EM	Element Management
EPC	Evolved Packet Core
EPCaaS	EPC as a Service
ETSI	European Telecommunication Standardization Institute
GRE	Generic Routing Encapsulation
GS	Group Specification
HSS	Home Subscriber Server
IaaS	Infrastructure as a Service
ICT	Information and Communication Technology
IETF	Internet Engineering Task Force
IFA	Interfaces and Architecture
KPI	Key Performance Indicator
LC	Lifecycle
LCid	Lifecycle Operation Occurance Id
LCM	Lifecycle Management
M&E	Media and Entertainment
M(V)NO	Mobile (Virtual) Network Operator
MANO	Management and Orchestration
MEC	Multi-access Edge Computing
MEO	Multi-access Edge Orchestrator
MEP	Multi-access Edge Platform
MILP	Mixed Integer-Linear Programming
MIoT	Massive Internet of Things
MLPOC	Multiple Logical Point of Contact
MME	Mobility Management Entity

<b>MNO</b>	Mobile Network Operator
<b>MON</b>	Monitoring
<b>MVNE</b>	Mobile Network Enabler
<b>NaaS</b>	Network as a Service
<b>NBI</b>	Northbound Interface
<b>NF</b>	Network Function
<b>NFP</b>	Network Forwarding Path
<b>NFV</b>	Network Function Virtualization
<b>NFVI</b>	Network Functions Virtualisation Infrastructure
<b>NFVlaaS</b>	NFVI as a Service
<b>NFV-NS</b>	NFV Network Service
<b>NFV-NSaaS</b>	Network Service as a Service
<b>NFV-NSO</b>	Network Service Orchestrator
<b>NFVO</b>	NFV Orchestrator
<b>NFVO-RO</b>	Resource Orchestrator
<b>NGMN</b>	Next Generation Mobile Networks
<b>NS</b>	Network Slice
<b>NSaaS</b>	Network Slice as a Service
<b>NSD</b>	Network Service Descriptor
<b>NS-DF</b>	Network Service Deployment Flavor
<b>NSI</b>	Network Slice Instance
<b>NSMF</b>	Network Slice Management Function
<b>NS-OE</b>	NFV-NS Orchestration Engine
<b>NSSI</b>	Network Slice Subnet Instance
<b>NSSMF</b>	Network Slice Subnet Management Function
<b>NST</b>	Network Slice Template
<b>OLE</b>	Onsite Live Experience
<b>ONAP</b>	Open Network Automation Platform
<b>OSM</b>	Open Source MANO
<b>OSS</b>	Operating Support System
<b>OTT</b>	Over the top
<b>PM</b>	Performance Management
<b>PMON</b>	Performance Monitoring
<b>PNF</b>	Physical Network Function
<b>PNFD</b>	PNF Descriptor
<b>PoC</b>	Proof of Concept
<b>PoP</b>	Point of Presence
<b>QoS</b>	Quality of Service
<b>RAM</b>	Resource Advertisement Management
<b>RAN</b>	Radio Access Network
<b>REST</b>	Representational State Transfer
<b>RM</b>	Resource Management
<b>RMM</b>	Resource Monitoring Management
<b>RNIS</b>	Radio Network Information Service
<b>RO</b>	Resource Orchestration
<b>RO-EE</b>	RO Execution Entity
<b>RO-OE</b>	RO Orchestration Engine
<b>RSU</b>	Road-Side Unit
<b>RTT</b>	Round Trip Time
<b>SAP</b>	Service Access Point
<b>SBI</b>	Southbound Interface
<b>SDK</b>	Software Development Kit

<b>SDO</b>	Standard Developing Organisation
<b>SLA</b>	Service Level Agreement
<b>SLPOC</b>	Single Logical Point of Contact
<b>SLPOC-F</b>	Single Logical Point of Contact for Federation
<b>SME</b>	Small and Medium Enterprises
<b>SO</b>	Service Orchestrator
<b>SPGW-C</b>	Serving/Packet Data Network Gateway Control Plane
<b>SPGW-U</b>	Serving/Packet Data Network Gateway User Plane
<b>TD</b>	Technology Domain
<b>TETRA</b>	Terrestrial Trunked Radio
<b>TMVS</b>	5G-TRANSFORMER Managed Vertical Service
<b>TN</b>	Transport Network
<b>TOSCA</b>	Topology and Orchestration Specification for Cloud Applications
<b>TRF</b>	5G-TRANSFORMER Resource Federation
<b>TSC</b>	5G-TRANSFORMER Service Consumer
<b>TSF</b>	5G-TRANSFORMER Service Federation
<b>TSP</b>	5G-TRANSFORMER Service Provider
<b>TUVS</b>	5G-TRANSFORMER Unmanaged Vertical Service
<b>UC</b>	Use Case
<b>UE</b>	User Equipment
<b>UPF</b>	User Plane Function
<b>VA</b>	Virtual Application
<b>vEPC</b>	virtual Evolved Packet Core
<b>VIM</b>	Virtual Infrastructure Manager
<b>VL</b>	Virtual Link
<b>VLAN</b>	Virtual Local Area Network
<b>VM</b>	Virtual Machine
<b>VNF</b>	Virtual Network Function
<b>VNFD</b>	VNF Descriptor
<b>VNFFG</b>	VNF Forwarding Graph
<b>VNFFGD</b>	VNFFG Descriptor
<b>VSD</b>	Vertical Service Descriptor
<b>VSI</b>	Vertical Service Instance
<b>WAN</b>	Wide Area Network
<b>WBI</b>	Westbound Interface
<b>WIM</b>	Wide area network Infrastructure Manager
<b>WP</b>	Workpackage
<b>YAML</b>	YAML Ain't Markup Language



## Executive Summary

The present deliverable called D7.3 presents the Part B of the First Periodic Report that will be delivered before 28th of August 2018. It mainly includes the information of the scientific work carried out between 1st of June 2017 and 30th of June 2018. It is important to highlight that the deadline of D7.3 is the 30th of June 2018, the final data for use of resources is still not available at the end of June. The full financial information will be included in the First Periodic Report in August.

This document includes the Publishable Summary, patents and dissemination activities that will be completed in the Participant Portal too, a description of the technical work carried out by beneficiaries and overview of the progress in the first 13 months of the project, including the objectives, the work performed by work package, the deliverables and milestones, the impact and finally the deviations of the project.

# 1 Publishable Summary

## 1.1 Summary of the context and overall objectives of the Project

### 1.1.1 Project context

"5G-TRANSFORMER: 5G Mobile Transport Platform for Verticals" is a 30-month collaborative project. The aim of the project is to apply SDN/NFV to transform current rigid mobile transport networks into a 5G dynamic system able to manage networking and computing resources tailored to the specific needs of vertical industries, such as eHealth, automotive, media, and industry 4.0. Additionally, network slicing, multi-access edge computing (MEC) and federation are seen as key enablers to allow such transformation. 5G-TRANSFORMER defines three main architectural building blocks: the Vertical Slicer (5GT-VS), for supporting the creation and management of slices for verticals; the Service Orchestrator (5GT-SO), for end-to-end service orchestration and federation of resources and services from multiple domains, and the Mobile Transport and Computing Platform (5GT-MTP), acting as the underlying fronthaul and backhaul transport network.

Main innovations delivered by the project are:

#### 5GT-VS

- 5GT-VS architecture and interfaces, allowing verticals, with no required expertise on service orchestration: (i) to describe vertical services by selecting a Vertical Service Blueprint (VSB) from a catalogue; (ii) to customize them into Vertical Service Descriptors (VSD) and to instantiate vertical services; and (iii) to control their lifecycle.
- Arbitrator and SLA management for intra- and inter-vertical priority handling.
- Slice management and VSD/NSD Translator for mapping a vertical service descriptor to a slice and its corresponding network service descriptor.

#### 5GT-SO

- 5GT-SO architecture and interfaces, aligned with ETSI NFV, including: (i) a Catalogue Manager and available Network Service and VNF repository, (ii) 5GT-MTP abstracted resources repository, (iii) network service instance repository; (iv) a network function virtualization orchestrator (NFVO) orchestrating both resources and services across multiple domains; (v) VNF Managers (VFNMs); and (vi) a monitoring platform.
- Service/resource orchestration and federation algorithms, allowing optimized actions based on different metrics and targeting resiliency, fault-tolerance and flexibility.

#### 5GT-MTP

- 5GT-MTP architecture, integrating MEC and decoupling of virtual infrastructure manager (VIM) from the NFVO and VFNMs.
- Ability to compose a connectivity service and expose it to the 5GT-SO.
- Resource abstraction using a single logical point of contact (SLPOC).

### 1.1.2 Project Objectives

Main objectives of the project are:

- To design a reference architecture for the 5G-TRANSFORMER platform, encompassing a flexible Mobile Transport and Computing Platform, a Service Orchestration platform, and a resource slicing platform for verticals.
- To design scalable algorithms for efficient 5G-TRANSFORMER service/resource orchestration: backhaul/fronthaul networking, computing, and storage.
- To support orchestration of end-to-end services across federated domains.
- 5G-TRANSFORMER key concepts validation and proof of concept.
- Communication, Dissemination, and exploitation (incl. standardization) of 5G-TRANSFORMER.

## 1.2 Work performed from the beginning of the project to the end of the period covered by the report and main results achieved so far

During this period, the project has focused on designing the 5G-TRANSFORMER architecture, developing the key concepts behind a true SDN/NFV/MEC mobile transport and computing platform capable of offering slices tailored to the specific needs of disparate vertical industries. The work in the project has been divided into 5 technical Work Packages (WPs). WP1 is in charge of defining the set of use cases and scenarios to be used to challenge the architecture of the system. WP1 is also in charge of designing the baseline architecture of 5G-TRANSFORMER (see Figure 1), which is aligned with the SDOs relevant in the area, mostly ETSI NFV and MEC. WP2 is in charge of the design and development of the 5GT-MTP, ensuring that it is capable of aggregating different technology domains and fulfil the requirements for different verticals. WP2 results during this period include the initial design of the 5GT-MTP architecture, starting from the analysis of the vertical requirements and use cases, integrating MEC, providing abstraction of resources and connectivity services to the 5GT-SO. WP3 is responsible of the design and development of the 5GT-VS. During the first reporting period, an initial design of the 5GT-VS architecture has been performed, with a focus on two aspects: (i) the definition of VSBs and how they are translated into VSDs that can be then converted into NSDs so they can be instantiated by the 5GT-SO, and (ii) the initial design of arbitration algorithms guaranteeing the availability of resources to high-priority vertical services. WP4 is in charge of the design and implementation of the 5GT-SO. In this first reporting period, an initial design of the 5GT-SO architecture has been released, based on the ETSI NFV specifications, and providing resource and service orchestration, both within one single administrative domain and among several domains (federation). WP4 has also worked on the first release of the 5G-T monitoring architecture. The main goal of WP5 is to integrate the components designed in WP2, WP3 and WP4 and to validate experimentally that the 5G-T architecture is capable of deploying slices fulfilling the requirements from various verticals. Main work of WP5 during this period has been the design and setup of the interconnection of the different test sites (as one example, the 5TONIC one is shown in Figure 2), as well as a first integration plan towards the implementation of several proofs of concept (PoCs) around the vertical use cases considered in the project.

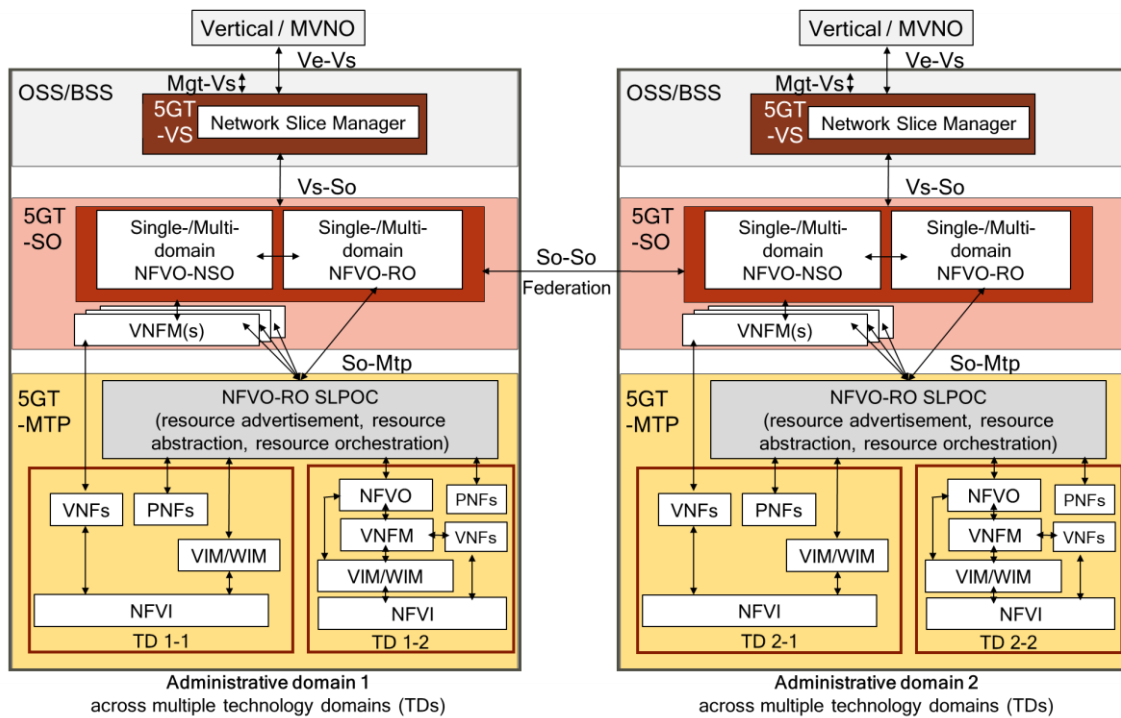

FIGURE 1: 5G-TRANSFORMER SYSTEM ARCHITECTURE

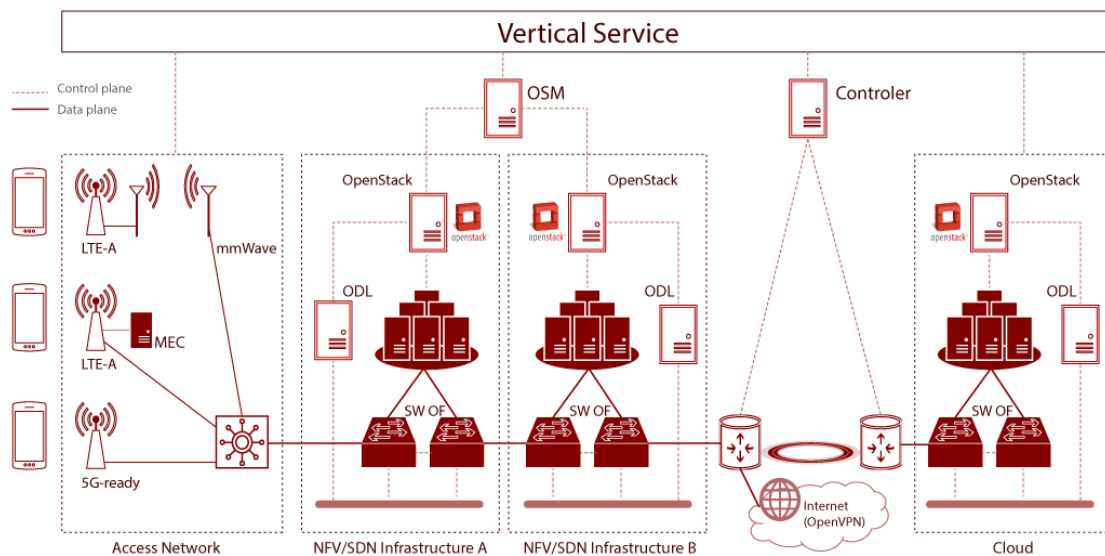

FIGURE 2: 5TONIC INFRASTRUCTURE

### 1.3 Progress beyond the state of the art and expected potential impact (including the socio-economic impact and the wider societal implications of the project so far)

The 5G-TRANSFORMER project targets innovations around the three main components of the project architecture: (1) Vertical slicer: offering a powerful, yet simple and flexible, interface to verticals to describe and consume slices tailored to their needs; (2) Service orchestrator: capable of instantiating and orchestrating the network services required by the vertical slices, including federation mechanisms

between different administrative domains; and (3) Mobile transport and computing platform, integrating compute, storage and networking resources, including MEC. All these innovations are combined together into an architecture framework that takes into account both technical and techno-economic requirements from the stakeholders of the value chain, namely operators, vendors and service providers.

All the above innovations are driven primarily by the need to make the future 5G networks more flexible and capable of adapt to offer slices capable of simultaneously meeting the disparate requirements of different verticals, whilst guaranteeing cost-efficient use of the resources. This results into a direct socio-economic impact, through lower cost and higher efficiency for the infrastructure stakeholders (operators, vendors, and service providers), and the end user customer in terms of better service (quality and ubiquitous access), and lower bills. The overall society will also see the benefit of driving the future transport network towards more flexibility and cost-efficiency, whilst supporting the various services envisioned in future 5G. In addition, the innovations from the 5G-TRANSFORMER project are expected to give the industrial companies (large, medium and small) in the project consortium and the extended European 5G-PPP community a privileged position and competitive advantage in the European and global markets through new generations of mobile networks. An exploitation plan is being defined to assess the possible impact on the product and services roadmaps of the vendors and operators involved in the project.

In order to ensure wide-reach of the innovations developed in the project, the consortium members have been very active in disseminating the project concept and early results to the European community (inside and outside 5G-PPP) and the wider international research and industrial community. The consortium has promoted the envisioned concepts and R&D achievements through various types of dissemination activities. In particular, the project has successfully delivered:

- 37 scientific publications.
- 6 (Co-)organized workshops.
- 6 demonstrations including at flagship events such as EuCNC 2018.
- 16 standard contributions.

## 2 Patents

The project has registered two Intellectual Property Rights, one by SSSA and one by IDCC:

- “Metodo per il ripristino della connessione di una rete di telecomunicazioni” (“Method for restoring the connection of a telecommunications network”). Submission Number: 102018000003571. Filed: 14 March 18.
- “Methods for advertising and selecting network slices dual-connectivity and multi-subscriber scenarios in 5G”, PCT Patent Application No 82707182, Filed: 08 August 2017.

### 3 Dissemination activities

This section describes the dissemination activities of 5G-TRANSFORMER during the first year. The dissemination activities follow the plan described in D6.1 [21], that is, publication of research results (Table 1), Technology Demonstration (Table 2), Academic activities (Table 3) and Organization and Participation in events (Table 4). A modification to the initial plan has to be highlighted. It is related to the participation to events in order to give technical talks related on 5G-TRANSFORMER topics, such as keynote, panels and technical presentation. Table 5 summarizes this new activity.

The first year of the project was very rich in terms of dissemination activities. Notably, 37 scientific publications have been published in peer reviewed journals, conferences and workshops (Table 1); 6 in Journals, 20 at conferences and 11 at workshops. Some of these publications are joint publications with other projects. Further, 5G-TRANSFORMER partners have participated to the organization of very successful events and workshops (Table 3) co-located with prestigious conferences. For example, we received positive feedback from COMPASS workshop attendees based on the poll circulated to the attendees. Most of these events were co-organized jointly with other projects.

Regarding the academic activities, several students have been enrolled to work on 5G-TRANSFORMER topics; 5 PhD, 2 Masters, and 2 Bachelor students have been enrolled during the first year.

Although it is the first year of the project, partners have made strong efforts to start demonstrating the 5G-TRANSFORMER results. In addition to an INFOCOM and Mobile World Congress demo, three demos were prepared for EuCNC 2018 on different topics treated in 5G-TRANSFORMER, and one was performed to the PSA group at 5TONIC premises.

**TABLE 1: PUBLICATIONS (J: PEER-REVIEWED JOURNAL, C: PEER-REVIEWED CONFERENCE, W: PEER-REVIEWED WORKSHOP)**

	Title	Venue
J	WizHaul: On the Centralization Degree of Cloud RAN Next Generation Fronthaul	IEEE Transactions on Mobile Computing (TMC), February 2018
J	Efficient Caching through Stateful SDN in Named Data Networking	Transactions on Emerging Telecommunications Technologies, Jan. 2018
J	Virtualization-based evaluation of backhaul performance in vehicular applications	Computer Networks, April 2018
J	5G-TRANSFORMER: Slicing and Orchestrating Transport Networks for Industry Verticals	IEEE Communications Magazine, accepted in 2018
J	On Enabling 5G Automotive Systems Using Follow Me Edge Cloud Concept	IEEE Transactions on Vehicular Technology (TVT), accepted 2018
J	Scheduling Advertisement Delivery in Vehicular Network	IEEE Transactions on Mobile Computing (TMC), accepted in 2018
C	Sharing of Crosshaul Networks via a Multi-Domain Exchange Environment for 5G Services	IEEE NetSoft 2017

C	A Simulation-based Testbed for Vehicular Collision Detection	IEEE VNC 2017
C	Software Defined 5G Converged Mobile Access Networks: Energy Efficiency Considerations	Asia Communications and Photonics Conference, 10 - 13 November 2017, The Garden Hotel, Guangzhou, Guangdong China
C	SDN-enabled Latency-Guaranteed Dual Connectivity in 5G RAN	Asia Communications and Photonics Conference, 10 - 13 November 2017, The Garden Hotel, Guangzhou, Guangdong China
C	Network Orchestration in Reliable 5G/NFV/SDN infrastructures	19th International Conference on Transparent Optical Networks (ICTON) 2017, Girona, Spain
C	Requirements for 5G fronthaul	19th International Conference on Transparent Optical Networks (ICTON) 2017, Girona, Spain
C	Network Orchestration in Reliable 5G/NFV/SDN infrastructures	19th International Conference on Transparent Optical Networks (ICTON) 2017, Girona, Spain
C	Virtualized eNB latency limits	19th International Conference on Transparent Optical Networks (ICTON) 2017, Girona, Spain
C	Joint VNF Placement and CPU Allocation in 5G	IEEE International Conference on Computer Communications (INFOCOM) 15-19, April 2018, Honolulu, USA
C	FluidRAN: Optimal vRAN/MEC Orchestration	IEEE International Conference on Computer Communications (INFOCOM) 15-19, April 2018, Honolulu, USA
C	Present-day verticals and where to find them: A data-driven study on the transition to 5G	IEEE WONS 2018
C	Service migration versus Service replication in Multi-access Edge Computing (MEC)	IEEE IWCMC 2018, June 24-29, Cyprus
C	Orchestrating Lightpath Adaptation and Flexible Functional Split to Recover Virtualized RAN Connectivity	OFC 2018, March 11-15, 2018, San Diego, CA, USA
C	Software Defined 5G Converged Access as a viable Techno-Economic Solution	OFC 2018, March 11-15, 2018, San Diego, CA, USA
C	Enabling Flexible Functional Split through software 5G converged access	IEEE ICC 2018, Kansas City, MO, USA
C	Performance analysis of C-V2I-based Automotive Collision Avoidance	IEEE WoWMOM 2018, Chania, Greece
C	Optimization-in-the-Loop for Energy-Efficient 5G	IEEE WoWMOM 2018, Chania, Greece
C	Experimental SDN Control Solutions for Automatic Operations and Management of 5G Services in a Fixed Mobile Converged Packet-Optical Network	IEEE ONDM 2018



C	Enabling Vertical Industries Adoption of 5G Technologies: A Cartography of Evolving Solutions	EuCNC 2018, Ljubljana, Slovenia
C	The Vertical Slicer: Verticals' Entry Point to 5G Networks'	EuCNC 2018, Ljubljana, Slovenia
W	Orchestrating Lightpath Adaptation and Flexible Functional Split to Recover Virtualized RAN Connectivity (poster)	URLLC 2017
W	WizHaul: An Automated Solution for vRAN Deployments Optimization	WSA 2018 - ITG workshop on smart antennas, March 2018
W	Service Orchestration and Federation for Verticals	IEEE WCNC COMPASS workshop, April 2018, Barcelona, Spain
W	5G Mobile Transport and Computing Platform for Verticals	IEEE WCNC COMPASS workshop, April 2018, Barcelona, Spain
W	Network Slices For Vertical Industries	IEEE WCNC COMPASS workshop, April 2018, Barcelona, Spain
W	Impact of RAN Virtualization on Fronthaul Latency Budget: An Experimental Evaluation	International Workshop on 5G Test-Beds and Trials - Learnings from implementing 5G (5G--Testbed 2017) co-located with Globecom 2017, Singapore
W	Understanding QoS applicability in 5G transport networks	WS3: Second Edition of the Workshop on Control and Management of Vertical Slicing including the Edge and Fog Systems, IEEE International Symposium on Broadband Multimedia Systems and Broadcasting, Valencia, June 2018
W	Multi-domain VNF mapping algorithms	WS3: Second Edition of the Workshop on Control and Management of Vertical Slicing including the Edge and Fog Systems, IEEE International Symposium on Broadband Multimedia Systems and Broadcasting, Valencia, June 2018
W	Towards a resilient OpenFlow channel through MPTCP	WS3: Second Edition of the Workshop on Control and Management of Vertical Slicing including the Edge and Fog Systems, IEEE International Symposium on Broadband Multimedia Systems and Broadcasting, Valencia, June 2018
W	Arbitration Among Vertical Services	Accepted in PIMRC 2018 workshop 'Vertical-Oriented Service Programmability: Design and Optimization of 5G Cell-Less Networks (5G Cell-Less Nets)'
W	Resource Orchestration of 5G Transport Networks for Vertical Industries	Accepted in PIMRC 2018 workshop 'Vertical-Oriented Service Programmability: Design and Optimization of 5G Cell-Less Networks (5G Cell-Less Nets)'

**TABLE 2: TECHNOLOGY DEMONSTRATIONS**

Title	Event
Demo of the initial heterogeneous network part of the MTP	Mobile World Congress'18
OVNES: Demonstrating 5G Network Slicing Overbooking on Real Deployments	IEEE INFOCOM 2018
Robotic Control Leveraging a Radio Network Information Service (RNIS)	EuCNC 2018
Orchestrating entertainment network service deployment in a hybrid cloud with Cloudify	EuCNC 2018
Creating a media-oriented slice through the 5G-TRANSFORMER vertical slicer	EuCNC 2018
5G network slices for mobile communication services	EuCNC 2018
5G Edge Assisted Robotics Trial	5TONIC internal demonstration to PSA group

**TABLE 3: ACADEMIC ACTIVITIES**

Title	Level	Status
eNB split functions (Distributed Unit --- DU --- and Central Unit -- CU) virtualization and its impact on fronthaul available latency budget.	PhD	Ongoing
Resource Orchestration in Virtualized Networks through SDN-enabled OpenStack	PhD	Ongoing
Software Defined Networking based mobility management in small cells	PhD	Ongoing
Mechanisms to integrate and enhance NFV and MEC	PhD	Ongoing
Design and optimization of solutions for discovery and federation for NFV in edge & fog scenarios	PhD	Ongoing
Multi-domain VNF mapping algorithms	Master	Defended
Development of a RNIS API based on Publish/subscribe using OAI	Master	Ongoing
Análisis de un orquestador NFV/SDN para redes de operador	Bachelor	Defended
Service Function Chaining en NFV: Evaluación práctica con OpenStack	Bachelor	Defended

**TABLE 4: ORGANIZATION OF EVENTS**

Title	Event
2 <sup>nd</sup> Workshop on Control and Management of Vertical Slicing including the Edge and Fog Systems (COMPASS) (under preparation)	Co-located with IEEE International Symposium on Broadband Multimedia Systems and Broadcasting, June 6th - 8th, 2018, Valencia, Spain. Jointly organized with 5G-CORAL and 5GEx projects
Multi-provider, multi-vendor, multi-player orchestration: from distributed cloud to edge and fog environments in 5G (under preparation)	Co-located with EUCNC 2018, workshop takes place on 18 June 2018, 09:00-18:00
1 <sup>st</sup> Workshop on Control and Management of Vertical Slicing including the Edge and Fog Systems (COMPASS)	Co-located with IEEE Wireless Communications and Networking Conference (WCNC) 2018, April,

	Barcelona. Jointly organized with 5G-CORAL project
Organization of the “5G technology for automotive domain” workshop in Turin including industrial and academic presentations	Industry-academia workshop organized in FCA, July 2017
Co-organization of a special session on 5G Mobile Transport Networks jointly with the 5G-Crosshaul project	Organized at Wireless World Research Forum (WWRF) 39 meeting in Barcelona, October 2017. More information available at: <a href="http://wwrf39.ch/WWRF.html">http://wwrf39.ch/WWRF.html</a>
Organization of IEEE VNC 2017	2017 IEEE Vehicular Networking Conference (VNC), Nov. 2017, Torino

**TABLE 5: PARTICIPATION TO EVENTS**

Title	Type	Event
Connected Car and Digital Transformation	Keynote	IEEE Vehicular Networking Conference (VNC), Nov. 2017, Torino, Italy
5G and Verticals: The Connected and Automated Driving (CAD) Case	Panel	IEEE Wireless Communications and Networking Conference (WCNC), April 2018, Barcelona, Spain
MVNOs World congress	Talk	MVNOs World Congress, April 2018
RS-FCN: Resource Slicing for Future Clouds and Networks	Talk	IEEE International Conference on Computer Communications (INFOCOM), April 2018, Honolulu, USA
All conference and workshop publications have been presented in their corresponding venue	Talk	Several international conferences and workshops (see publications table)

## 4 Explanation of the work carried out by beneficiaries and Overview of the progress

### 4.1 Objectives

This section is devoted to present the progress towards the fulfilment of the project objectives. For each of the objectives identified in the Description of Action (DoA), we present the details on how are they being tackled technically and by which WP.

Objective 1 5G-TRANSFORMER key concept validation and proof of concept		
Description	Demonstration and validation of 5G-TRANSFORMER technology components designed and developed in WP1, WP2, WP3 and WP4, and integrated in WP5 in an E2E 5G testbed.	
R&D Topics	WP/task	Details
Experimental validation of 5G-TRANSFORMER components and integrated platform.	WP5/T5.1	<ul style="list-style-type: none"> <li>Design, initial deployment and configuration of interconnection of the trial sites involved in the future validation of 5G-TRANSFORMER components. Described in D5.1 [6].</li> <li>Selection of use cases and Proof of Concept (PoCs) to be implemented and tested.</li> </ul>
	WP5/T5.2	<ul style="list-style-type: none"> <li>Initial planning of software components' features needed at each integration stage, according to the requirements of the PoCs.</li> </ul>
	WP5/T5.3 WP6/T6.2	<ul style="list-style-type: none"> <li>4 demos showing initial releases of the 5G-TRANSFORMER architecture components shown at EuCNC 2018.</li> </ul>
Verification	WP/task	Details
Demonstration of three verticals, namely automotive, eHealth and media distribution, over 5G-TRANSFORMER platform, having diverse requirements.	WP5/T5.1 WP5/T5.2 WP5/T5.3	<ul style="list-style-type: none"> <li>Initial demonstrations of early releases of 5G-TRANSFORMER components during EuCNC 2018.</li> </ul>
Demonstration integrating two federated domains.	WP5/T5.1 WP5/T5.2	<ul style="list-style-type: none"> <li>Interconnection of 5G-TRANSFORMER sites (required for future PoCs involving federation).</li> <li>Identification of the federation requirements posed by the different vertical-oriented PoCs.</li> </ul>
Performance evaluation of algorithms in the field fulfilling vertical SLAs as well as 5G-relevant KPIs on throughput, latency and energy.	WP5/T5.1 WP5/T5.2	<ul style="list-style-type: none"> <li>The demos shown at EuCNC 2018 include a qualitative evaluation of the vertical SLAs. D5.1 [6] includes a roadmap to deploy the PoCs of the corresponding use cases including their evaluation.</li> </ul>
Exhibiting at flagship events	WP5/T5.3	<ul style="list-style-type: none"> <li>4 demonstrations performed at EuCNC 2018.</li> </ul>

such as MWC 2018/19.		
<b>Objective 2</b>	<b>Design a reference architecture for 5G-TRANSFORMER platform</b>	
Description	Design a baseline architecture of the 5G-TRANSFORMER system that will serve as a reference for the technical work of WP2, WP3, WP4 and WP5. A first analysis of use-cases relevant to vertical sectors will set the requirements posed in the architectural design. The architecture will be validated through a techno-economic study and thorough implementation.	
R&D Topics	WP/task	Details
Analysis of 5G use-cases relevant for verticals and their requirements.	WP1/T1.1	<ul style="list-style-type: none"> <li>An analysis of the vertical scenarios from different perspectives, providing a robust and coherent set of requirements for the architecture design has been performed and reported in D1.1 [1]. The requirements are refined and complemented in D1.2 [2].</li> </ul>
5G-TRANSFORMER reference architecture design.	WP1/T1.2	<ul style="list-style-type: none"> <li>A description of the initial system design of the 5G-TRANSFORMER architecture, including the design of the main building blocks and the interfaces among them, as well as the interface towards the verticals is reported in D1.2 [2]. Additionally, it defines the high-level workflows among the building blocks for a set of basic service operations, showing the required interactions among the different building blocks on the related interfaces.</li> </ul>
Study on techno-economic impact of 5G-TRANSFORMER	WP1/T1.3	<ul style="list-style-type: none"> <li>The task devoted to this started in M13. Initial analysis of results from previous related projects such 5GEx is being analysed.</li> </ul>
Verification	WP/task	Details
Report a reference architecture design for 5G-TRANSFORMER.	WP1/T1.2	<ul style="list-style-type: none"> <li>Reference architecture design is included in D1.2 [2].</li> </ul>
Report on techno-economic study.	WP1/T1.3	<ul style="list-style-type: none"> <li>Ongoing work (T1.3 just started in M13).</li> </ul>
Implementation of the architecture and verification of the contribution to KPI.	WP1/T1.2 WP2 WP3 WP4 WP5	<ul style="list-style-type: none"> <li>Ongoing work planning the implementation of the 5G-T components, organized in different releases, to provide the functionality required by the vertical-oriented PoCs. First release almost ready for some components, such as the 5GT-VS.</li> </ul>
<b>Objective 3</b>	<b>Design a flexible Mobile Transport and Computing Platform (MTP)</b>	
Description	Design 5G-TRANSFORMER MTP by departing from 5G-Crosshaul MANO and adding native support for MEC along with transport control and virtualization technologies to flexibly place and move VNFs across the MTP.	
R&D Topics	WP/task	Details
Evolution of 5G-Crosshaul to encompass MEC, optimization of flexible placement	WP2/T2.1 WP2/T2.2	<ul style="list-style-type: none"> <li>The 5GT-MTP design extends the 5G-Crosshaul transport solution with MEC and dynamic creation of slices and placement of VNFs to take into account the needs of vertical industries, as reported in D2.1 [3].</li> </ul>

of VNFs in a multi-tenant scenario.		<ul style="list-style-type: none"> <li>The 5GT-MTP is able to support the deployment of MEC applications and services providing the following features: (i) advertisement of MEC hosts, including their characteristics (locations, capabilities, network connectivity to RAN and WIMs); (ii) deployment of MEC applications and configuration of the related traffic steering; (iii) advertisement of MEC services running in each MEC hosts; (iv) support of network interfaces towards the RAN to enable MEC services like Radio Network Information Service (RNIS). This is reported in D2.1 [3].</li> </ul>
Multi-level, multi-criteria abstraction and network clustering for hierarchical SDN/NFV control.	WP2/T2.1 WP2/T2.2	<ul style="list-style-type: none"> <li>The 5GT-MTP architecture supports multi-layer or multi-technology network infrastructures. In this case, SDN Controllers can be deployed in a hierarchical model to handle the heterogeneity of the technological domains through dedicated child controllers. In D2.1 [3], a model of abstraction have been reported to deal with transport network based on hierarchical SDN as well.</li> </ul>
Dynamic (de-)centralization and placement of VNFs (mobile system middleware) through composition/decomposition of VNF chains.	WP2/T2.2	<ul style="list-style-type: none"> <li>The 5GT-MTP provides a suitable abstraction (reported in D2.1 [3]) allowing the dynamic placement of VNF that can be centralized or decentralized according the requirements of the vertical service.</li> </ul>
Design an SDN/NFV architecture that can cope with multiple types of agents (e.g., wireless agents, packet system, optical agents).	WP2/T2.1	<ul style="list-style-type: none"> <li>The 5GT-MTP designed architecture supports heterogeneous Technological Domains, as described in D2.1 [3].</li> </ul>
Abstract information model to export parameters of MTP to the orchestrators serving the verticals (e.g., based on Transport SDN API).	WP2/T2.2	<ul style="list-style-type: none"> <li>Depending on the use case, the 5GT-MTP may offer different levels of resources abstraction to the 5GT-SO via the 5GT-MTP resource abstraction component, which in turn forwards the 5GT-SO requests to the right entity accordingly (as single point of contact): VIM/WIM, VNFM or PNF, or NFVO.</li> </ul>
Verification	WP/task	Details
Develop and demonstrate a proof-of-concept	WP2	<ul style="list-style-type: none"> <li>Ongoing work implementing the 5GT-MTP components.</li> </ul>

prototype of the MTP (TRL 3).		
<b>Objective 4</b>	<b>Design scalable algorithms for efficient 5G-TRANSFORMER resource orchestration: backhaul/fronthaul networking, computing, and storage</b>	
Description	Develop and evaluate integrated management and control algorithms for resource orchestration that ensure an appropriate service delivery and optimal resource utilization, despite dynamically changing traffic loads, available computational and network resources, wireless link fluctuations, flexible functional RAN splits and heterogeneous QoS requirements.	
R&D Topics	WP/task	Details
Scalable orchestration algorithms for dynamic joint optimization of routing and RAN/MTP/Core function placement.	WP2/T2.3	<ul style="list-style-type: none"> <li>An algorithm to optimize the placement of VNF considering joint optimization of routing, RAN/5GT-MTP/Core has been defined. It is based on the abstraction methods defined in T2.2 that aims at providing scalable solutions and reducing the dependency of the technological specific characteristics of the resources (e.g., transport, radio).</li> </ul>
Novel 5G-capable routing and traffic engineering algorithms using latency and jitter, wireless transport interference, user mobility, etc.	WP2/T2.2 WP2/T2.3	<ul style="list-style-type: none"> <li>Innovative abstraction methods have been defined and reported in D2.1 [3] to enable the implementation of algorithms allowing to perform routing and traffic engineering using values as latency, jitter for optimization. Such methods are based on a procedure that translates the technological specific parameters (e.g., wavelengths, etc.) of each domain in common parameters such as jitter and latency, in order to provide a homogeneous representation of the resources according to graph that enable the design on optimization algorithm that will be defined as next step.</li> </ul>
Novel capacity and Quality of Experience (QoE) optimization techniques required for verticals, optimization of MEC server location and server configuration, congestion-aware caching.	WP2/T2.3	<ul style="list-style-type: none"> <li>Ongoing work based on the 5G-MTP architecture and abstraction models defined in D2.1 [3]</li> </ul>
Techniques for path provisioning, mobility management, placement and re-location of VNFs based on multi-criteria optimization.	WP2/T2.3	<ul style="list-style-type: none"> <li>Algorithms defined for VNF placement. Further work will be done in the next reporting period.</li> </ul>

Techniques to support scalable and efficient distributed computing across heterogeneous vertical sectors.	WP2/T2.3	<ul style="list-style-type: none"> <li>Ongoing work based on architecture defined in T2.1.</li> </ul>
Verification	WP/task	Details
Simulative or analytical proof of scalability, throughput, latency, and computational performance of resource management algorithms.	WP2/T2.3	<ul style="list-style-type: none"> <li>Design and evaluation of an algorithm aiming at minimizing the overall cost providing the most optimal VNF placement in a multiple data-center scenario.</li> <li>Design, validation and evaluation of an on-line algorithm to provide quality-enabled VNFFG in remote data-centers interconnected through a multi-layer (packet over optical) network infrastructure.</li> </ul>
Prototype at least one algorithm on top of 5G-Crosshaul data plane.	WP2	<ul style="list-style-type: none"> <li>Ongoing work implementing the 5GT-MTP components.</li> </ul>
<b>Objective 5</b>	<b>Design a resource slicing platform for verticals (vertical slicer)</b>	
Description	Design and develop slicing techniques to address heterogeneous vertical-tailored requirements in a common cloud plus MTP infrastructure, including connectivity and vertical functions.	
R&D Topics	WP/task	Details
Study of dynamic resource partitioning techniques for connectivity, computing and storage resources in an integrated core/MTP network.	WP3/T3.2	<ul style="list-style-type: none"> <li>The arbitration component in the 5GT-VS assigns resources among vertical service instances. Dynamic reassignment is done in case of service instantiation, modification, and termination, and in case of changes of resource availability.</li> </ul>
Dynamic and flexible placement of vertical functions.	WP4/T4.1	<ul style="list-style-type: none"> <li>One of the main tasks of the 5GT-SO is the judicious placement of vertical functions, once translated into a network service by 5GT-VS. The system design and the algorithmic framework to achieve this objective are explained in D4.1 [5]</li> </ul>
Provide isolation across verticals and infrastructure provider.	WP3/T3.2	<ul style="list-style-type: none"> <li>Isolation is provided in 5G-TRANSFORMER by mapping vertical services to different network slice instances. The arbitrator in the 5GT-VS decides if an existing network service instance can be re-used based on the isolation constraints expressed in the SLA.</li> <li>The arbitrator also provides arbitration among several vertical service instances in case of resource shortage in the underlying infrastructure and based on global budgets for resource utilization of verticals.</li> <li>This is described in D3.1 [4] and in [24].</li> </ul>



Definition of blueprints used to create network slices.	WP3/T3.1	<ul style="list-style-type: none"> <li>The 5GT-VS allows defining vertical services from a set of vertical-oriented service blueprints, which, along with instantiation parameters, results in Vertical Service Descriptors (VSD). This is described in D3.1 [4] and in [25].</li> </ul>
Automatic service decomposition from template to form service graphs and requirements associated with the services.	WP3/T3.2	<ul style="list-style-type: none"> <li>The 5GT-VS maps the vertical service descriptions and requirements defined in the vertical service descriptors (VSD) onto a network slice, which we describe with extended ETSI NFV Network Service Descriptors (NSD). NSDs define forwarding graphs composed of a set of VNFs or Virtual Applications (VAs) connected with Virtual Links (VLs). This is described in D3.1 [4].</li> </ul>
Verification	WP/task	Details
Develop a proof-of-concept slicing platform for vertical services and demonstrate for three different verticals, automotive, eHealth, and media distribution.	WP3/T3.3	<ul style="list-style-type: none"> <li>Ongoing work implementing the 5GT-VS components. An initial version was demonstrated at EuCNC 2018.</li> </ul>
<b>Objective 6 Design a Service Orchestration (SO) platform</b>		
Description	Design a Service Orchestration (SO) platform in charge of service composition and orchestration of slices.	
R&D Topics	WP/task	Details
Service monitoring to verticals and mobile network operators.	WP1/T1.2 WP4/T4.2	<ul style="list-style-type: none"> <li>In the 5G-TRANSFORMER framework, each architectural component (i.e., 5GT-VS, 5GT-SO, 5GT-MTP) includes a monitoring service (as described in [2]) able to provide performance metrics and failure reports targeting the logical entities managed by each component: <ul style="list-style-type: none"> <li>The 5GT-MTP monitoring service produces monitoring data about the local physical and virtual resources.</li> <li>The 5GT-SO monitoring service produces monitoring data about the managed VNFs and NFV-NS.</li> <li>The 5GT-VS monitoring service produces monitoring data about network slices and vertical services.</li> </ul> </li> <li>The 5GT-SO Monitoring Service produces monitoring reports related to the performance or to failure events of the managed NFV network services and their VNFs. The monitoring reports can be used internally at the 5GT-SO, for example as triggers to auto-scaling procedures. This is described in D4.1 [5].</li> </ul>
Integration of resource and service orchestration by	WP4/T4.1 WP4/T4.3	<ul style="list-style-type: none"> <li>The 5GT-SO component is specified in D4.1 [5]. It has several components and one of them, the NFVO, orchestrates virtual resources across multiple domains, fulfilling the Resource</li> </ul>

vertical slicing.		<p>Orchestration (NFVO-RO) functions, and coordinates the deployment of NFV-NSs along with their lifecycle management, thus fulfilling the Network Service Orchestration (NFVO-NSO) functions.</p> <ul style="list-style-type: none"> <li>The 5GT-SO offers a Northbound API towards the 5GT-VS to support requests for service onboarding, creation, instantiation, modification, and termination. The 5GT-SO receives the service requirements from M(V)NOs and/or vertical industries via the SO-SAP interface in the shape of a Network Service Descriptors (NSD).</li> </ul>
Extension of homogeneous intent-based information and data models.	WP3 WP4	<ul style="list-style-type: none"> <li>Intent-based models have been acknowledged as requirements by both WP3 and WP4 to manage the deployment (and lifecycle) of vertical services (VS) and network services (ETSI-NS). To this aim, both D3.1 [4] and D4.1 [5] analyse several descriptors, among which TOSCA is the most promising to describe intent-based models.</li> </ul>
Automated “plug-and-play” service composition of heterogeneous VNFs through appropriate abstraction, interfaces, and layering.	WP4/T4.1 WP4/T4.3	<ul style="list-style-type: none"> <li>The result of decomposing a NFV-NS is a single or set of multiple nested NFV-NS. The decomposition of the requested NFV-NS is for further study. However, a single nested NFV-NS can be instantiated on a different administrative domain as a federated NFV-NS and together with the constituent nested NFV-NSs form the requested composite NFV-NS.</li> </ul>
Verification	WP/task	Details
Develop and demonstrate a proof-of-concept 5G-TRANSFORMER SO prototype (TRL 3).	WP4	<ul style="list-style-type: none"> <li>Cloudify selected as baseline 5GT-SO platform.</li> <li>Ongoing work implementing the 5GT-SO components.</li> </ul>
<b>Objective 7</b>	<b>Support orchestration of end-to-end services across federated domains</b>	
Description	Design and develop interfaces and algorithms to federate independent administrative domains, leveraging results from 5GEx 5G-PPP phase 1 project, to orchestrate end-to-end services. Federation of services offered by multiple domains (horizontal federation) and/or verticals (vertical federation).	
R&D Topics	WP/task	Details
Federation across multiple service providers’ domains aggregating networking and compute resources available in the infrastructure.	WP4/T4.3	<ul style="list-style-type: none"> <li>The So-So interface enables 5GT-SO to request/offer NFV-NSaaS and NFV-IaaS with other SOs. The So-So interface is based on the SLPOC for federation (SLPOC-F) solution of ETSI GS NFV-IFA 028. The SLPOC-F solution offers two modes of operation: direct and indirect. More details are provided in D4.1 [5].</li> </ul>
Control interfaces between federated MANO platforms.	WP4/T4.3	<ul style="list-style-type: none"> <li>The 5GT-SO eastbound/westbound interface (EBI/WBI) in the 5G-TRANSFORMER architecture provides federation of services and</li> </ul>

		federation of resources. The So-So interface has been defined based on ETSI NFVI IFA interfaces. More details are provided in D4.1 [5].
Verification	WP/task	Details
Experimental proof-of-concept (TRL 3) of successful federation between two independent administrative domains.	WP4/T4.3	<ul style="list-style-type: none"> <li>Ongoing work implementing 5GT-SO federation algorithms.</li> </ul>
<b>Objective 8</b>	<b>Dissemination, standardization and exploitation of 5G-TRANSFORMER</b>	
Description	Dissemination, standardization and exploitation of all concepts and technologies developed in the 5G-TRANSFORMER project.	
R&D Topics	WP/task	Details
Outreach communication to all stakeholders including the general public.	WP6/T6.1	<ul style="list-style-type: none"> <li>The project website has been setup. Around 5000 visits and 2000 visitors during the first year of the project. Around 4000 visits and 1800 visitors in the last quarters with the most visited page reaching more than 1000 visits (/publications).</li> <li>Increasing trend in all social media accounts (Twitter, Instagram and LinkedIn). Twitter: Number of impressions 10s of thousands in recent quarters (up to a max. of almost 33000). As of April 2018, Instagram: 19 followers and LinkedIn: 172 followers.</li> <li>A YouTube channel has been setup. 5 videos have been uploaded.</li> <li>Promotional material prepared (e.g., leaflets, posters, video).</li> </ul>
Dissemination to relevant industrial and academic communities.	WP6/T6.2	<ul style="list-style-type: none"> <li>Active participation in industrial events (like MWC 2018 and EuCNC 2018) and academic-related activities (such as Bachelor, Master and PhD programs).</li> <li>Organization and participation in multiple technical events to present the project and its results and exchange ideas with other projects.</li> </ul>
Maximization of the impact of project innovations through coordinated exploitation activities led by the innovation manager.	WP6/T6.2 WP7/T7.2	<ul style="list-style-type: none"> <li>An initial exploitation strategy has been reported in the Communication, Dissemination, And Exploitation Plan (CoDEP) for Y1 in D6.1 [21] and revised for Y2 in D6.2 [22].</li> </ul>
Contributions to top-tier scientific journals, conferences and magazines.	WP6/T6.2	<ul style="list-style-type: none"> <li>Multiple submitted, accepted and published papers in top-tier scientific journals, conferences and magazines, as reported in D6.2 [22].</li> </ul>
Contributions to standardization	WP6/T6.2	<ul style="list-style-type: none"> <li>A standardization advisory committee (SAC), formed from 5G-TRANSFORMER experts related</li> </ul>

bodies.		<p>to the relevant SDOs (3GPP, IETF, ETSI MEC, and IEEE) has been formed. The SAC supports partners to contribute to SDOs and to disseminate the project results.</p> <ul style="list-style-type: none"> <li>• A first version of the Standardization Activity Roadmap (SAR) has been produced. More details are provided in D6.2 [22].</li> <li>• Contribution to IETF, NGMN, 3GPP SA2 and ETSI MEC have been made as reported in D6.2 [22].</li> </ul>
Generation of IPR.	WP6/T6.2	<ul style="list-style-type: none"> <li>• Partners have clear plans to patent novel systems and/or methods related to the innovation outcomes of the project. Some initial filings have already taken place, despite of being still at the beginning of the project.</li> <li>• The project has also started to contribute to Open Source, even though the project <i>presentation of results</i> phase of the CoDEP. Initial developments, such as contributions to Virtlet (<a href="https://github.com/Mirantis/virtlet/blob/master/ACKNOWLEDGE.md">https://github.com/Mirantis/virtlet/blob/master/ACKNOWLEDGE.md</a>) and CRI Proxy (<a href="https://github.com/Mirantis/criproxy/blob/master/ACKNOWLEDGE.md">https://github.com/Mirantis/criproxy/blob/master/ACKNOWLEDGE.md</a>) upstream code have been made 5G-TRANSFORMER specific focus.</li> </ul>
Verification	WP/task	Details
At least 8 publications per year in top-tier scientific journals and conferences such as WCNC, ICC, INFOCOM, GLOBECOM, IEEE COMMAG/WIRELESSMAG, IEEE/ACM ToN.	WP6/T6.2	<ul style="list-style-type: none"> <li>• The first year of the project was very rich in terms of dissemination activities: 37 scientific publications have been published in peer reviewed journals, conferences and workshops; 6 in Journals, 20 at conferences and 11 at workshops. Some of these publications are joint publications with other projects.</li> </ul>
File at least 5 patent applications.	WP6/T6.2	<ul style="list-style-type: none"> <li>• 2 patent applications filed during the first year.</li> </ul>
At least 10 adopted contributions to SDOs such as 3GPP, IETF, ETSI, IEEE, ITU, ONF.	WP6/T6.2	<ul style="list-style-type: none"> <li>• 16 contributions to four different SDOs: 10 to IETF, 1 to 3GPP, 4 to ETSI MEC, and 1 to NGMN. Out of these 16, three of them have been adopted.</li> </ul>
Organization of at least 2 workshops.	WP6/T6.1	<ul style="list-style-type: none"> <li>• 3 workshops organized during the first reporting period: 1<sup>st</sup> COMPASS (co-located with IEEE WCNC 2018), 2<sup>nd</sup> COMPASS (co-located with IEEE BMSB 2018) and WS3 at EuCNC 2018. A technical session (Special Session #4: 5G Mobile Transport Networks) at wwf39 was also organized.</li> </ul>
At least 2	WP6/T6.1	<ul style="list-style-type: none"> <li>• 1 demo at MWC 2018 and 4 demos at EuCNC</li> </ul>

demonstrations per year, including one at flagship event such as MWC.		2018.
-----------------------------------------------------------------------	--	-------

## 4.2 Explanation of the work carried per WP

### 4.2.1 WP1

WP1 designs the baseline architecture of the 5G-TRANSFORMER system that will serve as a reference for the technical work of WP2, WP3, WP4 and WP5. WP1 analyzes and specifies requirements, high-level system design and associated business cases for the 5G-TRANSFORMER system. Our goal is to provide vertical industries with several levels of services and adapted features like, e.g., resources, isolation, QoS, mobility, etc. In T1.1 we have analyzed use cases from different verticals (e.g., eHealth, Automotive, and Media) to derive and classify their service specific requirements for the platform. Based on this analysis, we have designed in T1.2 the high level architecture, describing resources and services orchestration functions and their relations to the overall 5G transport architecture including RAN, flexible fronthaul/backhaul, Core and MEC network components. The designed architecture is then validated through implementation (work carried mainly by WP5) and through the work carried in T1.3 through a techno-economic study of the envisioned system, placing special emphasis on the benefits and costs of the solution for vertical industries deployments. The achieved implementation of the designed architecture should finally contribute to fulfil one of the project KPIs about **reducing today's network management OPEX by at least 20%**.

#### 4.2.1.1 Task 1.1: Vertical analysis and requirements

The first period of the activity was devoted to the analysis of the vertical domains and their use case scenarios from different perspectives in order to provide a robust and coherent set of requirements that served to design the baseline architecture and its components. The defined set of requirements covers mainly technical aspects related to service provisioning and management (e.g., latency, capacity, performance requirements), environment (energy consumption), and social (cooperation among multiple telecom operators from different regions and interfacing with different vertical industries).

This task was led by CRF who was also the editor of D1.1. The weekly calls were chaired by ORANGE with help of CRF. All partners involved in this task participated to the weekly calls. In particular, partners responsible of vertical domains (ATOS, CRF, ORANGE, BCOM, TID, UC3M) presented at several occasions the use cases per vertical domain and elaborated the input for the use cases analysis in D1.1. CRF provided the methodology of the use case analysis as well as the requirements extraction and analysis. ORANGE, UC3M, NECLE and NOKIA helped on the finalization of D1.1 and its review. NECLE helped on providing a first analysis of the stakeholders and ecosystem. UC3M contributed on elaborating the KPIs analysis

The achieved work in this task was reported in deliverable D1.1 [1] and can be described as follows:

- **ECOSYSTEM AND STAKEHOLDERS ANALYSIS**

We provided an analysis of the ecosystem and stakeholders of 5G-TRANSFORMER as well as an overview of the challenges for each vertical domain involved in the project.

The stakeholders and ecosystem analysis included mainly a study of gaps between the different existing SDOs (mainly 3GPP, NGMN and ETSI) and tried to capture the challenges and opportunities in them for 5G-TRANSFORMER.

- **VERTICAL USE CASES ANALYSIS**

We provided a detailed analysis of the vertical industries (Automotive, eHealth, Media, e-Industry and MNO/MVNO), highlighting their peculiarities and the main characteristics of their use cases, in order to derive and classify an initial set of requirements for the telecommunication infrastructure and to guide activities related to the architecture design and the services definition. For this, we started with an analysis of the challenges for each vertical domain that outlined the technical, technological and business needs for each vertical sector. This analysis included:

- An overview of the vertical industry that highlights the main challenging characteristics, identifying eventually different operating scenarios.
- An UML Diagram illustrating the involved actors.
- A list of high-level needs that should be addressed by the 5G technologies.
- A description of the future challenges.

Based on this analysis, we provided a more a detailed technical description of use case scenarios that illustrates the needs and challenges defined in the previous analysis for each vertical domain. We used a template to provide the necessary information for each use case scenario. Besides, in order to facilitate later on the design of the network slice types, we performed a clustering of the use case scenarios identified for all the vertical domains into 3 main clusters that correspond to defined slice types in SDOs (e.g., 3GPP, NGMN).As such, the field "Cluster" in the template is used for this purpose with the following 3 main cluster types that we identified:

- Enhanced Mobile Broadband (eMBB).
- Mission Critical Services.
- Massive Internet of Things (Massive IoT).

During T1.1, we have identified and described 44 use cases covering all the vertical domains and listed in Table 1:

TABLE 1: EXHAUSTIVE LIST OF 5G-TRANSFORMER USE CASES

Vertical domains	Number of use cases	List of use cases
Automotive	25	<ul style="list-style-type: none"> <li>- Cooperative V2V Safety application.</li> <li>- V2I Safety application.</li> <li>- Driver monitoring application.</li> <li>- See through (Safety).</li> <li>- Vulnerable Road User (VRU) Discovery.</li> <li>- Cooperative Navigation &amp; Distributed Mobility Management.</li> <li>- Dynamic Reserved Lane Management (Emergency vehicle, Public transportation).</li> <li>- Collaborative Parking.</li> <li>- Smart Cities.</li> <li>- See ahead.</li> <li>- Road Issues Identification &amp; Notification.</li> <li>- Black Spot Identification &amp; Notification.</li> <li>- Dynamic High Definition Map Update.</li> <li>- Bird's Eye View.</li> <li>- Personalized &amp; Contextual Information.</li> <li>- Video streaming.</li> <li>- On line gaming.</li> <li>- Augmented reality.</li> <li>- OTA SW Upgrade.</li> <li>- Remote Driving.</li> <li>- Remote Processing for Vehicles.</li> <li>- Floating Car Data for Predictive Maintenance.</li> <li>- Automated overtake.</li> <li>- Cooperative Collision Avoidance.</li> <li>- High-Density Platooning.</li> </ul>
e-Entertainment	4	<ul style="list-style-type: none"> <li>- On-site live event experience.</li> <li>- Ultra-high fidelity media.</li> <li>- Immersive and Integrated Media.</li> <li>- User Generated Content.</li> </ul>
e-Health	3	<ul style="list-style-type: none"> <li>- Heart attack emergency.</li> <li>- Environmental information.</li> <li>- Remote surgery.</li> </ul>
e-Industry	6	<ul style="list-style-type: none"> <li>- Monitoring.</li> <li>- Cloud robotics.</li> <li>- Automated logistics.</li> <li>- Electrical utilities: Generation.</li> <li>- Electrical utilities: Transmission.</li> <li>- Electrical utilities: Distribution.</li> </ul>
MNO/MVNO	6	<ul style="list-style-type: none"> <li>- vEPCaaS.</li> <li>- Cloud data for URLLC.</li> <li>- vMonitoring as a Service.</li> <li>- MCPTT network deployment using private RAN.</li> <li>- MCPTT network deployment using local dedicated RAN (over on-boarded infrastructure).</li> <li>- MCPTT network deployment using local dedicated RAN (over operator's RAN).</li> </ul>

- **HIGH LEVEL REQUIREMENTS EXTRACTION**

From the previous detailed analysis of the use cases per vertical domain, we extracted a set of high-level requirements for each vertical domain based on the following methodology:

1. Listing of the requirements qualifying the identified service use cases: This step consists on listing the assumptions for the realization of each UC. Requirements were categorized as Functional or Non Functional. For this, we used a template to characterize each requirement (see Table 3).
2. Matching the UCs requirements to the KPIs: At this step, we started by defining the KPIs relevant to the different vertical domains. The definitions are provided in Table 2 along with the values that we used to characterize each KPI parameter. The methodology consists then on matching the UCs requirements to the KPIs. The challenge of this step resides in the fact that the clustered UCs of the different clusters identified in the previous step, might be in use at the same time. From a network point of view, this implies the necessity to satisfy very different requirements at the same time.
3. Pointing out the different requirements that shall be satisfied simultaneously

**TABLE 2: KPIs DEFINITION**

KPIs	Definitions	Values		
		Low	Medium	High
End-to-end latency [LAT][ms]	E2E latency or one trip time latency.	1-10	10-50	>50
Reliability [REL][%]	Refers to the continuity in the time domain of correct service and is associated with a maximum latency requirement. More specifically, reliability accounts for the percentage of packets properly received within the given maximum E2E latency (one trip latency or round trip time (RTT) depending on the service).	<95	95-99	>99
User data rate [UDR][Mbit/s]	Minimum required bit rate for the application/service to function correctly.	<50	50-100	100-1000
Density [DENS][device s/km <sup>2</sup> ]	Maximum number of devices per unit area under which the specified reliability should be achieved	<1000	1000-10000	≥10000
Mobility [MOB][km/h]	<b>No:</b> static users. <b>Low:</b> pedestrians (0-3 km/h). <b>Medium:</b> slow moving vehicles (3-50 km/h).	<3	3-50	>50



	<b>High:</b> fast moving vehicles, e.g., cars and trains (>50 km/h).			
Type of Traffic [TRA]	Depending on to the amount of data flowing across a network at a given point of time, the traffic can be: <ul style="list-style-type: none"> <li>• Continuous</li> <li>• Bursty</li> <li>• Event driven</li> <li>• Periodic</li> <li>• All types.</li> </ul>	Event Driven/ Periodic	Bursty/ Continuous	All types
Availability [A-COV] (related to coverage)	The availability in percentage is defined as the number of places (related to a predefined area unit or pixel size) where the QoE level requested by the end-user is achieved divided by the total coverage area of a single radio cell or multi-cell area (equal to the total number of pixels) times 100.	<95	95-99	>99
Positioning accuracy [POS][cm]	Maximum positioning error tolerated by the application.	100-1000	30-100	<30
Confidentiality [CON]	Preserving authorized restrictions on information access and disclosure, including means for protecting personal privacy and proprietary information. <ul style="list-style-type: none"> <li>- <b>Basic:</b> unauthorized disclosure of information could have a limited adverse effect.</li> <li>- <b>Moderate:</b> unauthorized disclosure of information could have a serious adverse effect.</li> <li>- <b>Elevated:</b> unauthorized disclosure of information could have a severe or catastrophic adverse effect.</li> </ul>	Basic	Moderate	Elevated
Integrity [INT]	Guarding against improper information modification or destruction, and includes ensuring information non-repudiation and authenticity. <ul style="list-style-type: none"> <li>• <b>Basic:</b> The unauthorized modification or destruction of information could be expected to have a limited adverse effect on organizational operations, organizational assets, or individuals.</li> <li>• <b>Moderate:</b> The unauthorized</li> </ul>	Basic	Moderate	Elevated

	<p>modification or destruction of information could be expected to have a serious adverse effect on organizational operations, organizational assets, or individuals.</p> <ul style="list-style-type: none"> <li>• <b>Elevated:</b> The unauthorized modification or destruction of information could be expected to have a severe or catastrophic adverse effect on organizational operations, organizational assets, or individuals.</li> </ul>			
Availability [A-RES] (related to resilience)	<p>Ensuring timely and reliable access to and use of information.</p> <ul style="list-style-type: none"> <li>• <b>Basic:</b> The disruption of access to or use of information or an information system could be expected to have a limited adverse effect on organizational operations, organizational assets, or individuals.</li> <li>• <b>Moderate:</b> The disruption of access to or use of information or an information system could be expected to have a serious adverse effect on organizational operations, organizational assets, or individuals.</li> <li>• <b>Elevated:</b> The disruption of access to or use of information or an information system could be expected to have a severe or catastrophic adverse effect on organizational operations, organizational assets, or individuals.</li> </ul>	Basic	Moderate	Elevated
Communication range [RAN] (m)	Maximum distance between source and destination(s) of a radio transmission within which the application should achieve the specified reliability.	<300	300-800	>800
Infrastructure [INF]	<p><b>Limited:</b> no infrastructure available or only macro cell coverage.</p> <p><b>Medium density:</b> Small number of small cells.</p> <p><b>Highly available infrastructure:</b> Large number of small cells.</p>	Limited	Medium density	Highly available
Energy reduction [NRG]	Reduction of the energy consumption of the overall system.	<20%	20-80%	>80%

	The most common metric that is used to characterize this KPI is the reduction in the consumed Joules per delivered bit.			
Cost [CST]	Expenditure of resources, such as time, materials or labor, for the attainment of a certain HW or SW module. OPEX and CAPEX are important components of the overall costs	TBD in T1.3	TBD in T1.3	TBD in T1.3
Service creation time [SER]	The time required to provision a service, measured since a new service deployment is requested until the service has been provisioned).	<90 seconds	90 minutes	>90 hours

- **SELECTED VERTICAL APPLICATION SCENARIOS**

We provided a detailed description of the use cases that are candidates for being validated via Proof of Concepts in the final demonstrators. The analysis of the selected use cases has been used as an input for T1.2 and T1.3 and the rest of technical WPs, enabling the definition of a suitable solution, coping with the intended vertical markets. Moreover, the output of this analysis is also used in T5.1 for the design and configuration of the vertical testbeds. For each vertical domain, the selection of use case was done considering the potential benefits given by the 5G infrastructure provided by the project. Each selected use case is analyzed through the following information:

- A general overview of the use case.
- A detailed use Case Description containing mainly the goal of the use case, a brief description, the list of actors, preconditions and post conditions, as well as a call flow for the use case execution.
- An UML UC diagram illustrating the involved actors and the related functions.
- A high-level Sequence Diagram showing the message exchanged between the main expected modules.
- A logical high-level architecture showing the main modules and their interaction.

Mainly, 5 use case application scenarios were identified (1 application scenario per Vertical domain). In Table 5, we capture these use case application scenarios and the relevant KPIs that characterize them from the previously mentioned KPI list in Table 4.

TABLE 3: USE CASE APPLICATION SCENARIOS AND THEIR ASSOCIATED KPIs

Vertical Use case application scenario	Description	Relevant KPIs
Automotive: <i>Cooperative Urban cross traffic</i>	An Intersection Collision Avoidance service that is able to calculate in real time the probability of collision and the speed profile and act consequently. The demonstrator shall verify that the service will be running correctly when a video streaming service is running on board at the same time.	<ul style="list-style-type: none"> <li>• High Reliability &amp; availability (99%).</li> <li>• Ultra-Low Latency (&lt;20 ms).</li> <li>• High Security.</li> <li>• High Priority.</li> <li>• Enhanced data rate.</li> </ul>
Entertainment: <i>On-site Fan experience</i>	A mobile device application (“Spectator App”) that will enrich the fan experience at a sport venue through features like access to all statistics and forecasts, watch live views from another position, automatic push notifications, replay best & most amazing moments, immersive experiences using AR, etc.	<ul style="list-style-type: none"> <li>• High User Data Rate.</li> <li>• High Reliability.</li> <li>• Low Latency.</li> <li>• High Density.</li> </ul>
E-Health: <i>Heart Attack Emergency</i>	The patient has a smart wearable which can monitor precise cardiac, respiratory, sleep and activity data. This information is transmitted in raw to the cloud using a 5G Network and is then processed and analyzed. If an issue is detected, an alarm is generated towards the user and an emergency event is reported to emergency services.	<ul style="list-style-type: none"> <li>• Low end-to-end latency.</li> <li>• High reliability.</li> <li>• High security.</li> <li>• High confidentiality and integrity.</li> </ul>
MNO/MVNO: <i>5G Network as a Service</i>	Offers a Network as a Service to MVNOs and MNO customers through the deployment of tailored slices for different needs and the combination of two usages: <ul style="list-style-type: none"> <li>• The deployment of a dedicated virtual core network vEPC to manage local multi-access technologies in a very dense environment.</li> <li>• The provision of mission critical services leveraging on the local infrastructure.</li> </ul>	<ul style="list-style-type: none"> <li>▪ Low End-to-end latency.</li> <li>▪ High Reliability.</li> <li>▪ High User data rate.</li> <li>▪ High Density.</li> <li>▪ Low Mobility.</li> <li>▪ High Type of Traffic.</li> <li>▪ High Availability.</li> <li>▪ High Confidentiality.</li> <li>▪ High Integrity.</li> <li>▪ High Availability (related to resilience).</li> <li>▪ Medium Infrastructure.</li> </ul>

<p>E-Industry: <i>Cloud Robotics for Industrial automation</i></p>	<p>A Cloud Robotics service for factory automation where robots and production processes are remotely monitored and controlled in a cloud, exploiting wireless connectivity (LTE/5G) to minimize infrastructure, optimize processes, and implement lean manufacturing. The objective of the demonstrator is to verify the interaction and coordination of multiple (fixed and mobile) robots controlled by remote distributed services.</p>	<ul style="list-style-type: none"> <li>• Ultra-Low Latency (this requirement depends on the functions moved in the cloud).</li> <li>• Enhanced data rate.</li> <li>• High Reliability &amp; availability (99.999%).</li> <li>• High Security.</li> </ul>
------------------------------------------------------------------------	---------------------------------------------------------------------------------------------------------------------------------------------------------------------------------------------------------------------------------------------------------------------------------------------------------------------------------------------------------------------------------------------------------------------------------------------	----------------------------------------------------------------------------------------------------------------------------------------------------------------------------------------------------------------------------------------------------------

- **KPI ANALYSIS**

The final outcome of the work in T1.1 is a common set of requirements and associated priorities in alignment with the project targeted KPIs, which are meant to be taken as input for T1.2 and T1.3 and the rest of technical WPs, enabling the definition of a carrier-grade solution, coping with the intended vertical markets. After the extended analysis of use cases per vertical domain, the extraction of their high level requirements, the selection of the relevant use case application scenario for the project per vertical domain, and the definition of the relevant KPIs, we went through an extended analysis of the project KPIs with regards to the 5G-PPP KPIs. For this purpose, we first clustered the KPIs in 3 categories indicating their level of relevance for the project (see Table 6). We did afterwards the mapping between these KPIs and the 5G-PPP KPIs (see Table 7).

**TABLE 4: KPIS CHARACTERIZATION AND RELEVANCE**

KPIs		Relevance
Performance KPIs		
P1	Providing 1000 times higher wireless area capacity and more varied service capabilities compared to 2010.	High
P2	Saving up to 90% of energy per service provided.	High
P3	Reducing the average service creation time cycle from 90 hours to 90 minutes.	High
P4	Creating a secure, reliable and dependable Internet with a “zero perceived” downtime for services provision.	Low
P5	Facilitating very dense deployments of wireless communication links to connect over 7 trillion wireless devices serving over 7 billion people.	Medium
Societal KPIs		
S3	European availability of a competitive industrial offer for 5G systems and technologies.	High
S5	Establishment and availability of 5G skills development curricula (in partnership with the European Institute of Innovation and Technology).	Medium

Business KPIs		
<b>B1</b>	Leverage effect of EU research and innovation funding in terms of private investment in R&D for 5G systems in the order of 5 to 10 times.	Medium
<b>B2</b>	Target SME participation under this initiative commensurate with an allocation of 20% of the total public funding.	High
<b>B3</b>	Reach a global market share for 5G equipment & services delivered by European headquartered ICT companies at, or above, the reported 2011 level of 43% global market share in communication infrastructure.	Medium

TABLE 5: MAPPING BETWEEN 5G-TRANSFORMER AND 5G-PPP KPIs

	5G-PPP KPIs						
	P1	P2	P3	P4	P5	S3	
LAT						X	
REL				X			
UDR	X						
A-COV					X	X	
MOB					X		
DEN					X		
POS					X		
CON				X			
INT				X			
A-RES				X			
TRA	X						
RAN					X		
INF					X		
NRG		X					
CST		X	X				
SER			X				

#### 4.2.1.2 Task 1.2: High-level architecture design of 5G-Mobile Transport and Computing Platform for Verticals

This task designs the overall 5G-TRANSFORMER architecture, supporting “verticals” and “legacy” networks, with regards to the requirements and analysis done in T1.1. The baseline architecture has been developed and fed into WP2/3/4 for their respective technology developments. The final outcome of the task is the system design of the 5G-TRANSFORMER architecture, which covers the underlying transport components, the main 5G network functions within 5G Edge encompassing MEC, and technological building blocks dedicated to resource and service orchestration for vertical slices. NECLE, UC3M, ORANGE, TID, Telefonica, NOKIA, MIRANTIS, NXW, BCOM, CTTC contributed actively to the design of the baseline architecture functions, the interfaces

between its main functional blocs and APIs (VS-SO, SO-MTP), as well as the elaboration of the main call flows (on-boarding, termination, instantiation). SSSA, EURECOM, MIRANTIS, NXW contributed to the MEC related discussions and the elaboration of their related services within the architecture. IDCC coordinated the work on possible implication of 3GPP standardization activities on system design activities. BCOM, ORANGE and NXW were actively contributing to the discussions about federation. Besides, NXW actively contributed to the discussions about the monitoring platform. In addition, a common document was elaborated to include the common input parts of WP1, WP2, WP3 and WP4.

Moreover, all partners involved in this task were actively participating to the dedicated technical architecture discussions and to the weekly calls. A dedicated call was held weekly and chaired by NECLE for this purpose. The output of T1.2 was reported in deliverable D1.2 [2] and can be summarized as follows:

- **5G-TRANSFORMER business ecosystem, its stakeholders model and the offered services**

Based on the definitions provided by 3GPP and NGMN, we further defined and identified the different 5G-TRANSFORMER stakeholders, the basic relationships established among them and the services offered or consumed by each of them (see Figure 3).

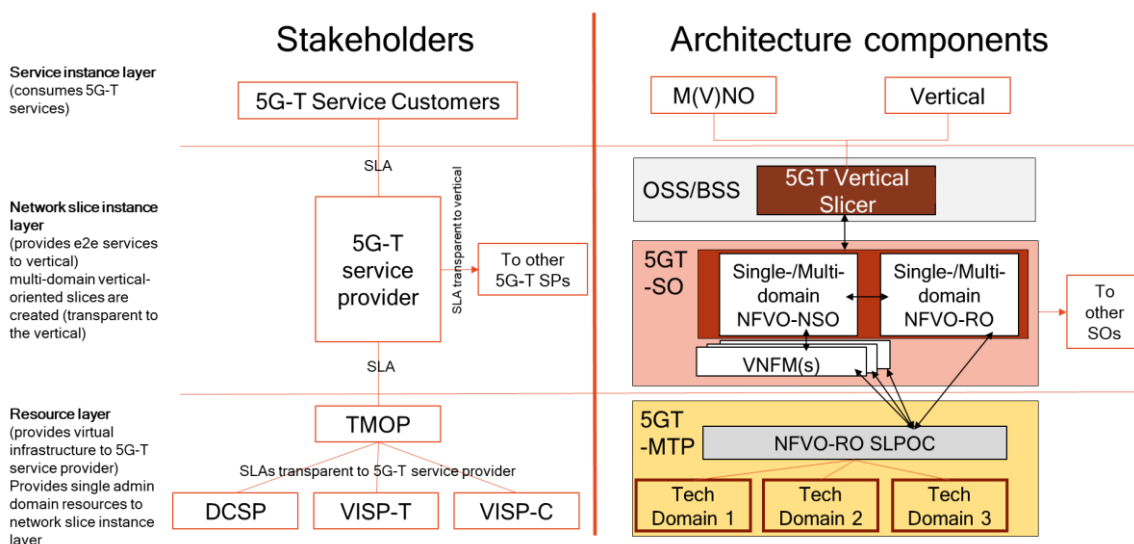

**FIGURE 3: 5G-TRANSFORMER STAKEHOLDERS MAPPING WITH THE SYSTEM ARCHITECTURE**

From a business perspective, 5G-TRANSFORMER Services (TS) are services focused on a specific industry or group of customers with specialized needs (e.g., automotive services, entertainment services, e-health services, industry 4.0). TS are offered by a 5G-TRANSFORMER Service Provider (TSP) to 5G-TRANSFORMER Service Consumers (TSC) such as verticals through its northbound interface or to other TSPs through the east-west interface (EBI/WBI). We defined a set of 4 types of 5G-TRANSFORMER vertical services as described in Table 8. In addition to these 4 services, we have also identified 2 services that can be consumed by TSPs in the case of federation. The interaction between the peering TSPs is done through the east-west interface (EBI/WBI) of 5GT-SOs. There are two types of service federation: 5G-

TRANSFORMER Service federation (TSF) and 5G-TRANSFORMER Resource federation (TRF).

**TABLE 6: 5G-TRANSFORMER SERVICES**

<b>5G-TRANSFORMER Services</b>	<b>Description</b>
<b>5G-TRANSFORMER Managed Vertical Service (TMVS)</b>	These vertical services are fully deployed and managed by the TSP and consumed as such by the vertical (i.e., without any interface available to modify the service logic, but only for getting operational information, at most)
<b>5G-TRANSFORMER Unmanaged Vertical Service (TUVS)</b>	Vertical services are deployed by the TSP (i.e., VNFs and their connectivity), but their logic is partly or fully managed by the vertical. This includes the configuration of VNF internals to control the logic of the vertical services at service level, e.g., the algorithms for ICA (Intersection Collision Avoidance) for the automotive use case. In this case, the lifecycle management of the NFV network service and its VNFs is still retained by the TSP.
<b>Network Slice as a Service (NSaaS)</b>	To provide a network along with the services that it may support. For instance, a TSP may provide a mMTC network slice as a service, which may support several services, including sensor monitoring, collision avoidance as well as traffic management, and warehouse automation. The TSC (i.e. the NSaaS customer) can, in turn, play the role of a provider itself, and offer to its own consumers its vertical services built on top of the services of the network slice (B2B2X). Based on mutual agreement, the relevant network slice characteristics and some limited network slice management capability need to be exposed.
<b>NFVI as a Service (NFVaaS)</b>	The tenant (e.g., a vertical or an MVNO) is offered a virtual infrastructure including associated resources (networking/computing/storage) under its full control, in which it can deploy and manage its own NFV network services on top of it. It is assumed that the vertical will deploy its own MANO stack. This is probably the most usual service consumed by M(V)NOs, since they have the knowledge and the need to customize their communication service offering for their own customers. Resources could be virtual cores, storage, virtual nodes and links, etc.

- **Selection of the final set of vertical services and use cases**

Based on the input from D1.1 about the selected use case application scenarios, partners representing vertical domains (ATOS, CRF, UC3M, ORANGE, TID) provided



an extended description of these use cases explaining for each of them the motivation of their selection. The selected use cases are summarized in Table 8 per vertical domain.

Vertical domains	Selected use cases
<b>Automotive</b>	Intersection Collision Avoidance (ICA) (UC A.01, UC A.02)
<b>e-Entertainment</b>	On-site live event experience (OLE) (UC.E01)
<b>e-Health</b>	Heart attack emergency (UC.H.01)
<b>MNO/MVNO</b>	vEPCaaS (UC M.01)
<b>e-Industry</b>	Cloud Robotics (UC I.02)

- **The 5G-TRANSFORMER system requirements**

The extracted requirements are split into two major groups: business and functional requirements. The functional requirements are grouped along the different phases of a vertical service instance: discovery, fulfillment, assurance, and decommissioning. This contribution was led by Telefonica. It was reviewed by ORANGE, NOKIA and NECLE.

- **The 5G-TRANSFORMER baseline architecture design**

The main contribution of the task T1.2 in D1.2 [2] is the design of the 5G-TRANSFORMER baseline architecture with its three main functional blocks, including the Vertical Slicer (5GT-VS), the Service Orchestrator (5GT-SO), the Mobile Transport and Computing Platform (5GT-MTP) and the interfaces among these components. The details of the contribution on the internal architectural design of these components and their related interfaces are detailed in the sections related to their WPs.

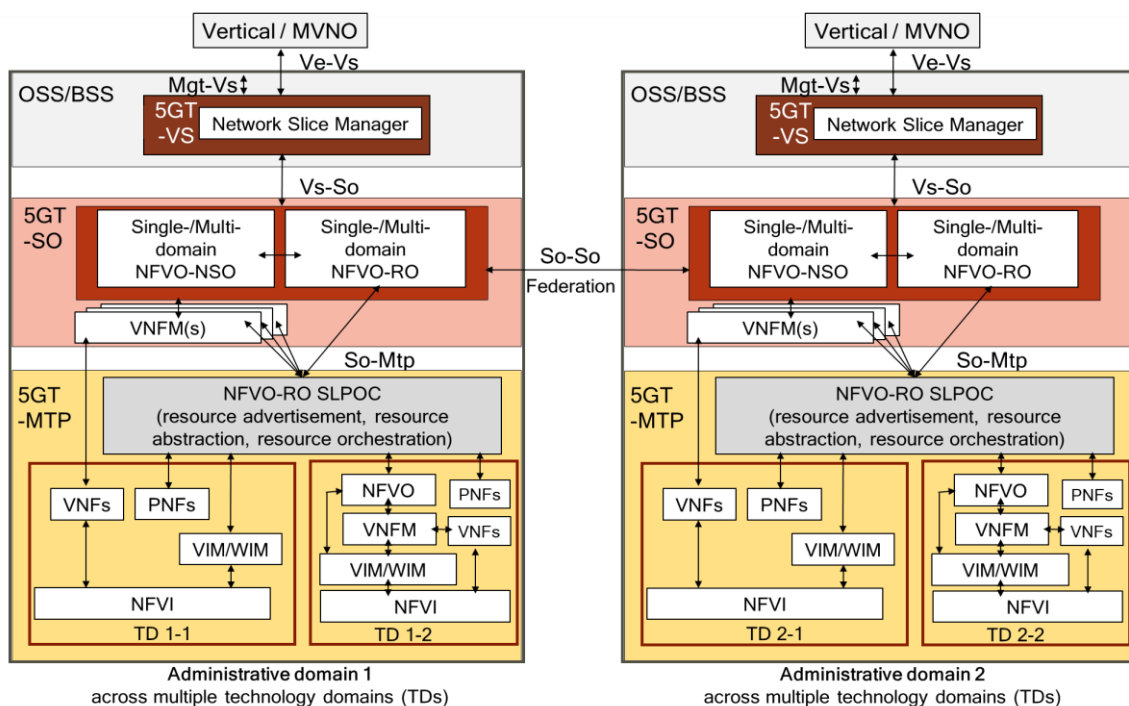

**FIGURE 4: 5G-TRANSFORMER SYSTEM ARCHITECTURE**

In D1.2 [2], the network slicing concept is introduced, and we explain how to map vertical services to network slices and how to manage them. We also provide a detailed discussion on the different architecture options for federation and Multi-access Edge Computing (MEC) integration. A glossary edited and led by NOKIA on the relevant terminology was also provided as Annex in D1.2. Most partners participated to the elaboration of the glossary definitions. In addition to the baseline architecture design presented hereafter in Figure 4, we also discuss the architecture challenges for service deployment in environments composed of multiple technology domains.

We also designed and described a monitoring architecture for our architecture framework. Each architectural component (i.e., 5GT-VS, 5GT-SO, 5GT-MTP) includes a monitoring service able to provide performance metrics and failure reports targeting the logical entities managed by each component. Following this approach, the 5GT-MTP monitoring service will produce monitoring data about the local physical and virtual resources, the 5GT-SO monitoring service will produce monitoring data about the managed VNFs and NFV-NSs, while the 5GT-VS monitoring service will produce monitoring data about network slices and vertical services. This hierarchy of monitoring services is shown in Figure 5, where the arrows indicate a consumer-provider interaction. In particular, the 5GT-SO monitoring service can be a consumer of the monitoring service provided by the underlying 5GT-MTP or by a federated 5GT-SO, while the 5GT-VS can be a consumer of the monitoring service provided by the local 5GT-SO. The monitoring data generated at each layer can be used to feed internal decisions within each architectural component or to serve external consumers of monitoring data.

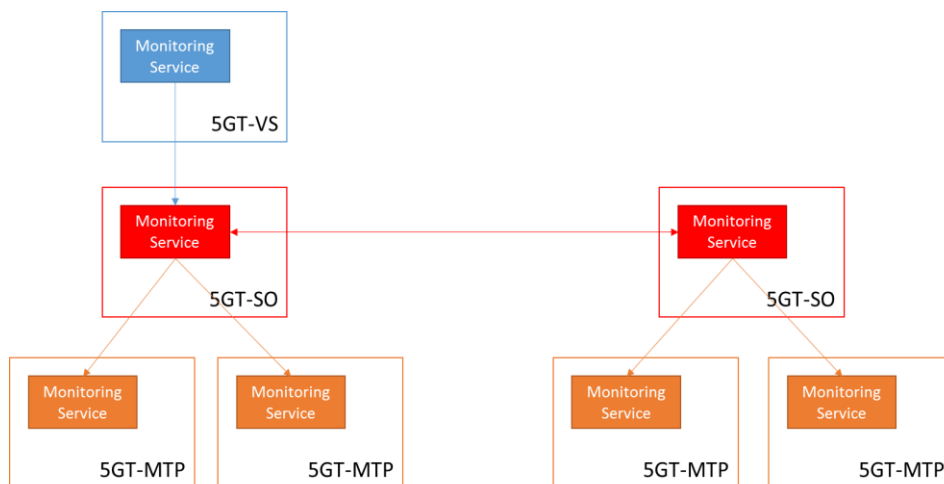

**FIGURE 5: HIERARCHY OF MONITORING SERVICES IN 5G-TRANSFORMER ARCHITECTURE**

- **The workflows among a vertical and the three main components of the system**

We detailed in D1.2 [2] the main workflows describing the ordered sequence of information and messages passed among the main building blocks of our 5G-TRANSFORMER architecture. We focused on the most important workflows. For instance, we detailed the workflows for on-boarding, instantiating, and terminating a non-nested vertical service. We also describe its modification and monitoring while being in operational status. We also described the workflow for instantiating a composite vertical service, embedding multiple nested services.

Dissemination of the 5G-TRANSFORMER architecture design and steering related standardization activities (activities collected by WP6), are of paramount interest of the project and has resulted in a number of contributions to academic journals and conferences [27][25][28][29] and standardization bodies [30][31][32][33]. The initial system architecture design has been also presented to the 5GPP Architecture WG in May, 2018.

#### 4.2.1.3 Task 1.3: Techno-Economic Analysis

5G-TRANSFORMER aims at offering an infrastructure composed of heterogeneous transport networking and computing resources from one or multiple administrative domains, providing network and vertical services offering business and cost benefits for traditional and potential new stakeholders. The activity in T1.3 aims at analyzing the market and business implications of 5G-TRANSFORMER by identifying the business opportunities for operators and service providers in a newly constructed ecosystem leveraging on the 5G-TRANSFORMER architecture, their capability to capture value and the potential appearance of the new actors and roles. This activity will use as basis the verticals' use cases and requirements from T1.1 and the high level architecture components from T1.2, as well as Techno-Economic analysis performed in relevant phase 1 projects like 5G-Crosshaul and 5GEx.

The task started at M12 and is led by Telefonica. For the time being, there is no significant output to be reported for this task in the first period of the project. Future output will be reported in the second period report.

#### 4.2.1.4 Deviations

Globally, the work package is proceeding as planned. No deviations have been noticed during the first period of the project.

#### 4.2.1.5 Corrective actions

No corrective actions are needed.

### 4.2.2 WP2

The 5GT-MTP is a single point of contact of the 5GT-SO and it is responsible for orchestration of resources and the instantiation of VNFs over the infrastructure under its control, as well as managing the underlying physical mobile transport network, computing and storage infrastructure. According to the 5G paradigm, processing and storage resources dedicated for vertical applications could be distributed in small data-centers that are connected to each other by the transport and mobile network resources. Hence the 5G-MTP has been defined as a novel block that manages the complexity of multi-domain transport and mobile resources providing a suitable abstract view to the 5GT-SO. This approach allows to decouple the operations on the networking resources orchestration that are delegated to the 5G-MTP with respect to the virtual function placements for vertical applications delegated to the 5GT-SO. The 5GT-MTP acts as single point towards the 5GT-SO providing the abstract view of the mobile and transport resources and, at its turn, translates the requests from the 5GT-SO in resources requests to the transport and mobile resources respectively.

In the first reporting period, the activity carried out in the WP2 related to the following main topics, which will be detailed in the related subsections of this chapter:

- The definition of the architecture of the 5GT-MTP, with related procedures and workflow, the definition of the API towards the 5GT-SO.
- The definition of the abstract model to expose to the 5GT-SO in order to hide the complexity and the heterogeneity of the transport and radio domains.

- The definition of the algorithms to optimize the resource usage.

Moreover, to assess the abstraction model and related API, a mapping of relevant vertical use cases defined by WP1 and described in D1.1 [1] has been done.

#### 4.2.2.1 Task 2.1: MTP orchestrator: architecture, procedures, API

The main activity of the first reporting period has been to define the architecture of 5GT-MTP taking care to be compliant with the general architecture of 5G-TRANSFORMER defined in WP1. Moreover, alignment with WP4 has been done for the 5G-MTP-5GT-SO interface (NECLE, SSSA, TEI).

IDCC coordinated the task and the editing of deliverable D2.1. TEI, SSSA, CTTC, NXW contributed to define the internal architecture of the 5G-MTP, while CTTC, IDCC, SSSA and TEI, on the basis of the abstraction methods defined in T2.2 (TEI, SSSA) provided an abstraction modelling for the API towards 5GT-SO. ATOS defined business requirements according to the general requirements defined in WP1 of the 5G TRANSFORMER architecture and the specific requirements of 5GT-VS (NOK-N) and 5GT-SO (NECLE).

An analysis of the status of the art (BCOM, ORANGE, UC3M, SSSA) has been done both considering European projects and standards (ETSI) in order to understand which part was missing in the existing solutions to deal with vertical services support. According to the 5G paradigm, processing and storage resources dedicated for vertical applications could be distributed in small data-centers that are connected to each other by the transport and mobile network resources. Moreover, transport and mobile networks could be complex (i.e., multi-domain, heterogenous technologies) and could belong to different providers. Hence, starting from the architecture defined by ETSI NFV, the functions of NFVO and resources orchestration have been basically split between the 5GT-SO and 5GT-MTP, delegating to the 5G-MTP the task to manage the complexity of transport and mobile resources and providing to the 5GT-SO a suitable abstraction view. An analysis of MEC support (EURECOM) has also been done and reported in D2.1.

As reported in Figure 6 the 5GT-MTP resources are data-centers (DC) for the applications for verticals, transport networks (WAN) usually consisting of multiple domains with heterogenous technologies and controlled by SDN, and mobile network resources. Typically, the data-centers are geographically connected to each other by WAN and mobile networks. The WIM is assumed as the entity devoted to control mobile and transport networks to provide the connections or communications among the DCs. The 5GT-MTP manages the complexity of such heterogenous resources (transport and mobile) exposing to the 5GT-SO one or more sets of logical links as connections among the DCs. Hence, internally the 5GT-MTP receives the requests from the 5GT-SO on the abstract view and translates them in the corresponding resources of the WAN, mobile network and DC to be configured and/or activated according to the different use cases.

This architecture extends the 5G-Crosshaul transport solution [11] with dynamic creation of slices and placement of VNFs to take into account the needs of vertical industries. Figure 6 presents the 5GT-MTP technology domains TD1-1 and TD1.2 mapping with the ETSI NFV MANO architecture, with related extensions, highlighting three architectural alternatives:

- Case 1: the 5GT-MTP exposes virtual resources and the possibility to instantiate entire VNFs through the VNFM.
- Case 2: the 5GT-MTP exposes PNFs that can be configured but not instantiated (e.g. a physical BTS). At the VIM/WIM level the 5GT-MTP only instantiates virtual resources related to networking.
- Case 3: the 5GT-MTP abstracts an entire network service to the 5GT-SO and it takes care internally about how to orchestrate it, through the NFVO - VNFM - VIM/WIM stack.

It is worth noting that case 1 and case 2 correspond to the 5GT-MTP TD1-1 while case 3 corresponds to the 5GT-MTP TD1.2.

TEI, SSSA, IDCC and NXW defined the internal work flow of the 5GT-MTP that has been discussed with WP3 (NOK-N) and WP4 (NECLE) to be compliant with the corresponding workflow of the 5GT-VS and the 5GT-SO. The analysed workflows have been associated with the following lifecycle events: instantiating a non-nested network service, modifying a non-nested network service, terminating a non-nested network service, VNF instantiation, VNF termination and monitoring of virtual resources.

As example, the internal interface between 5GT-MTP and the WAN has been defined and reported as appendix in the D2.1 (SSSA, TEI), based on IFA 005 [13].

All partners of T2.1 (UC3M, TEI, ATOS, IDCC, TID, ORANGE, BCOM, NXW, MIRANTIS, CTTC, EURECOM, SSSA, ITRI) have intensively participated both during the weekly meeting and in the conducted face-to-face meeting during the plenary meetings done so far.

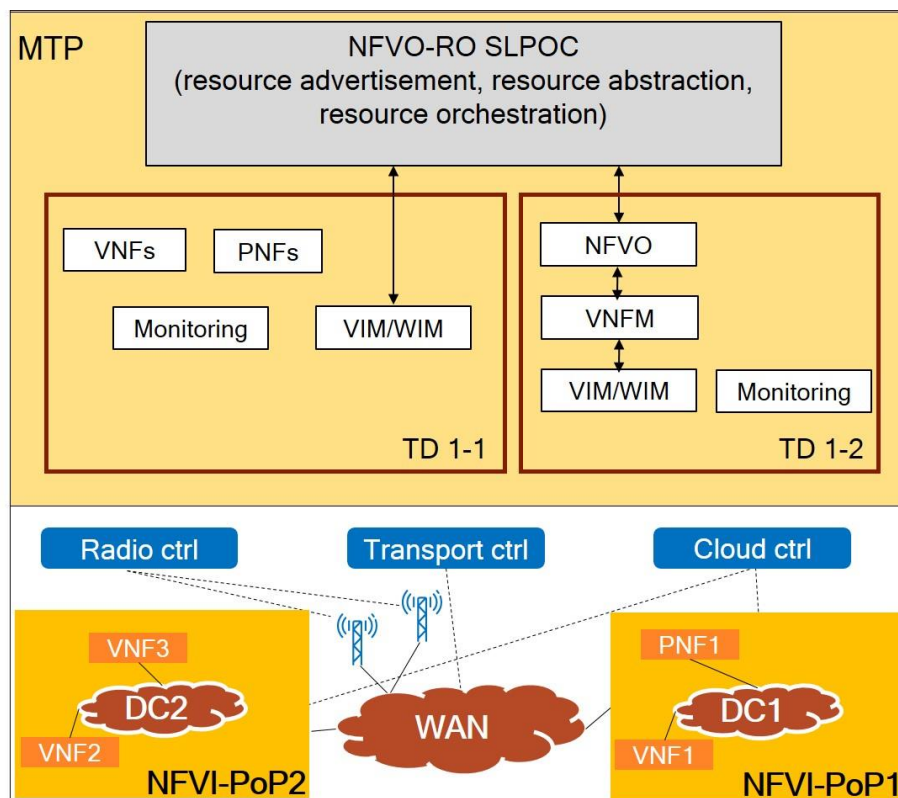

FIGURE 6: 5GT-MTP ARCHITECTURE

#### 4.2.2.2 Task 2.2: Mobile-Transport abstraction method in support of MEC services and Slicing

This task has defined abstraction models that have been assessed considering relevant use cases defined in WP1 according the requirements described in D1.1.

In tight interworking with the T2.1 and the general architecture defined in WP1, TEI and SSSA defined three models of abstractions: in the first model all resources from transport, mobile and data-centers are exposed; in the second model only transport resources and mobile resources implemented on dedicated hardware are abstracted in logical links, while the data-centers that can be utilized either for the applications of the verticals or to run virtual functions of the radio running on generic processing are not abstracted, but are exposed to the 5GT-SO; the third model includes in the logical links both transport and mobile resources independently if the mobile functions are implemented on dedicated hardware or on generic processing. Based on the scalability analysis, the second and third model have been considered as reference for the abstraction to 5GT-SO. Starting from the requirements of the services defined in D1.1, a list of parameters have been associated to each abstraction model. Such parameters (e.g. delay, availability, bandwidth, etc) are independent of the technical specific parameters of the WAN and mobile domains that provide them (e.g. optical parameters, etc.).

Specifically, POLITO, TEI, UC3M, ATOS jointly worked to perform the mapping of “Connected Car”, Cloud Robotics, eHealth, and Entertainment on the abstraction model and verify the suitability of the proposed model. Moreover, ORANGE and BCOM worked on the vEPCaaS (Virtual EPC as a service) as additional use case that differs from the first one because it provides mobile functions such as the vEPC as a service.

The abstraction models defined in T2.2 has been used as reference to define the 5GT-MTP-5GT-SO interface in T2.1 and optimization algorithms in T2.3.

TEI coordinated the task and the contribution of T2.2 topics in the deliverable D2.2 in order to be compliant with the interface with 5GT-SO and related abstraction model of the API defined in T2.1.

All partners actively participated on discussion both during the weekly meeting and during the F2F meeting providing fruitful contribution

#### 4.2.2.3 Task 2.3: Methods and optimization algorithms for optimal placement of virtual functions, selection of best radio splitting and transport resource to support MEC-oriented service

The principal objective addressed by this task is to provide innovation on algorithms and mechanisms to achieve cross-domain optimization of heterogeneous resources entailing cloud and networking (e.g. radio, packet, optical, etc.) when accommodating a myriad of network services used to deal with the vertical requirements. In other words, T2.3 activities are devoted on proposing the mechanisms and algorithms targeting multiple objective functions (e.g., minimize cost, satisfy QoS needs, etc.) being executed at a dedicated 5GT-MTP’s Resource Orchestration (RO) entity according to the specific vision kept by the 5GT-MTP.

CTTC has analysed the state of the art of algorithms and mechanisms produced in the literature. This work will be continually checked and updated in order to retrieve already presented works, identifying performance metrics, adopted view of the resources, complexity of the mechanisms, etc.

In a joint work, both CTTC and SSSA has focused on designing, validating and evaluating an on-line algorithm to provide quality-enabled VNFFG in remote datacenters interconnected though a multi-layer (packet over optical) network infrastructure. A scheme for recovery Distributed Unit (DU) and Central Unit (CU) connectivity upon optical metro link soft failure has been defined and analysed. This study showed that a two-step recovery scheme orchestrating lightpath transmission adaptation and evolved NodeB (eNB) functional split reconfiguration preserves the Virtualized RAN fronthaul connectivity even when network capacity is scarce.

POLITO worked on an algorithm aiming at minimizing the overall cost providing the most optimal VNF placement in a multiple datacenter scenario. To do that, POLITO is defining and proposing a reference model to be used at the time of devising any algorithm with the same objective functions. To this end, a queuing-based system model has been defined, accounting for all the entities involved in 5G networks. Then, a fast and efficient solution strategy yielding near- optimal decisions has been analysed. This approach has been evaluated in multiple scenarios that well represent real-world services and found to consistently outperform state-of-the-art alternatives and to closely match the optimum.

NECLE has investigated and explored algorithms addressing the RAN split.

Finally, all partners within T2.3 (i.e., TEI, UC3M, ATOS, ORANGE, BCOM, NXW, EURECOM, CTTC, SSSA, NECLE) have been intensively participated (i.e., proposing potential enhancements to cover other technologies of specific intricacies of the underlying infrastructure, etc.) in the conducted face-to-face meeting during the plenary meeting done so far.

An expected and planned outcome of this collaboration of the T2.3 involved partners is the production of a joint paper to be submitted to PIMRC conference algorithms and mechanisms for the VNF placement in 5G-TRANSFORMER.

#### 4.2.2.4 Deviations

Overall, the work package is proceeding as planned. There are changes for one partner regarding the effort they plan to spend within WP2. EURECOM is shifting 5PM related to MEC from WP3 to WP2.

#### 4.2.2.5 Corrective actions

No corrective actions are needed.

### 4.2.3 WP3

The Vertical Slicer (5GT-VS) is the entry-point for verticals to the whole 5G-TRANSFORMER system. Within WP3 there are three tasks focusing on the description of vertical services (T3.1), algorithms within the 5GT-VS (T3.2), and implementation of the 5GT-VS and support of vertical service implementations (T3.3).

#### 4.2.3.1 Task 3.1: Vertical service descriptors

Most importantly, the 5GT-VS allows the verticals to define vertical services - by selecting a Vertical Service Blueprint (VSB) from a catalogue and completing it to a Vertical Service Descriptor (VSD) - and to instantiate them without having to be experts in service orchestration. VSBs and VSDs are central concepts of the 5GT-VS. WP3 analyzed the use cases from WP1 for properties to be expressed in VSBs and VSD.

This analysis of the use cases was complemented by an analysis of existing approaches to describe network services.

WP3 (UC3M, ATOS, NOK-N, IDCC, ORANGE, BCOM, SAMUR, CRF, CTTC, POLITO) analysed the five use cases selected in WP1 (intersection collision avoidance, onsite live event experience, heart-attack emergency, cloud robotics for industrial automation, 5G-network as a service) for technical, business-related, and lifecycle requirements. Technical requirements are related to service level requirements of the actual vertical services, e.g. which communication latency is needed or how many UEs have to be supported. Business related requirements are related to how a vertical interacts with the 5G-TRANSFORMER system, e.g. a vertical shall be able to select a VSB from a catalogue. Lifecycle related requirements are related to instantiation, modification, terminating, and monitoring vertical service instances (VSI). The technical requirements had mostly been defined in D1.1 [1]. Business and lifecycle related requirements were described in D3.1 [4].

Service descriptions of ETSI NFV [12], TOSCA [17], and from the SONATA project [18] were analysed regarding their expressiveness. Eventually, a table based presentation format for VSBs and VSDs was proposed by NOK-N, IDCC, and TID. This format was described in D3.1 [4]. VSBs consist of three different groups of fields for identification, structural information, and service constraints. An example of a simple VSB for a service to determine latency among servers on different sites is shown in Table 7.

**TABLE 7: VSB FOR LATENCY PROBE**

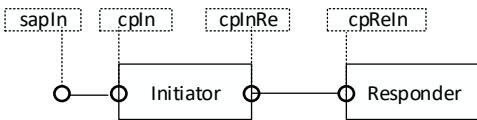
Field	Description
Name	Latency Probe
Description	An Initiator and Responder Linux Server are connected to each other. The vertical can login to the Initiator and trigger Pings to the Responder.
Version	2.0
Identity	Xyz4712_bp
Parameters	<loc1, Coordinate, "location of cpInRe", Service Constraints/cpInRe location> <loc2, Coordinate, "location of cpReIn", Service Constraints/cpReIn location>
Atomic functional components involved	stdLinux (see D3.1 [4])
Service sequence	VNFFG in textual notation (ETSI NFV IFA 014) of 
Connectivity service	sapIn - cpIn, cpInRe - cpReIn: L3VPN
External interconnection	sapIn
Internal interconnection	n/a



SST	n/a (see the field SLA instead)
Service constraints	cpInRe location: <<MetroArea of this sap>> cpReIn location: <<MetroArea of this sap>>  Geographical area: n/a; Security: low; Priority: medium; Cost: n/a; Synchronization: low; etc.
Management and control capabilities for the tenant	Provider managed
SLA	n/a
Monitoring	n/a
Lifetime	On-demand, 1h
Charging	To be defined

The fields for identification provide a name, description, version, internal reference, and most importantly the list of parameters of the VSBs. These parameters define what has to be provided by a vertical to turn the VSB in a complete VSD. The fields for structural information define the functional components, internal and external connection points, connectivity among functional components and connection points, and the type of service used to do so. This information is similar to the one provided in ETSI NFV Network Service Descriptors (NSD) [12]. Eventually, the service constraints describe various types of requirements on vertical services, e.g. technical requirements as explained before, expected lifetime of a service, or whether a vertical service instance is managed by the provider or the vertical.

A VSD has similar fields as a VSB. There is no longer a list of parameters, instead there is a field to indicate from which VSB a VSD was derived.

The example VSB in Table 7 is one of a set of VSB and VSD examples provided by ATOS, NOK-N, and IDCC. Examples covering services for sensor monitoring, onsite live event experience, latency measurements, and Cloud/Edge robotics, have been presented in D3.1 [4]. The definition of the VSBs and VSDs for the five UCs has been started by the partners working on the UCs.

When a vertical requests instantiation of a VSD, the VSD is mapped to a network slice instance (NSI) by the 5GT-VS, where network slices are described themselves by ETSI NFV NSDs. Actually, the 5GT-VS has to map VSDs to NSDs. Based on the expressiveness analysis mentioned before, UC3M, NOK-N, NXW, and EURECOM identified necessary extensions of NSDs. NSDs refer already to descriptors of virtual network functions (VNFD). To support multi-access edge computing (MEC), NSDs are extended to reference also to descriptor of MEC applications (AppD). Most SLA requirements of vertical services are translated by the 5GT-VS to deployment flavours. Some SLA requirements influence placement decisions, e.g. latency constraints among a connection point and a VNF. These placement decisions are made in the 5G-TRANSFORMER system by the service orchestrator (5GT-SO) and the corresponding SLA requirements have to be passed from the 5GT-VS to the 5GT-SO. We extended NSDs and their instantiation parameters with the possibility to express latency constraints along a path and to express location constraints of service access points.

Vertical services are of different complexity. Some can be described by a single VSB, others are composed from child services. Note, child services may have different owners, they may have different lifetimes, they may be mapped to the same or to different NSIs. UC3M, NOK-N, ATOS, ORANGE, and NXW analysed the impact of composed vertical services on VSBs and VSDs. Such composed services can be described within VSBs and VSDs by adding references to these descriptions, further extensions are not needed here. ETSI NFV NSDs can already be nested, no extensions are needed for them.

#### 4.2.3.2 Task 3.2: Algorithms for Verticals

Without going into the details of the 5GT-VS design there is a task of the 5GT-VS where algorithms play a central role. These tasks are the arbitration of resources among VSIs and the mapping of VSIs to NSIs. Both tasks are handled by the Arbitrator component of the 5GT-VS.

The underlying physical infrastructure may not have sufficient resources to accommodate all VSIs requested by verticals, even when federating with other infrastructure providers. Also, a vertical may have agreed with the service provider on a maximum amount of resources to be used for its VSIs to keep its costs under control. In both cases, there are VSIs which do not get as many resources as needed to achieve their intended Key Performance Indicators (KPI). UC3M, ATOS, NOK-N, ORANGE, NXW, CTTC, and POLITO have defined corresponding functionality to assign resources based on priorities to VSIs as well as the information to be exchanged with other components to perform this task. The goal of the Arbitrator design was to keep the business logic - definition of priorities and resource budgets and using this information - within the 5GT-VS and using the 5GT-SO purely as engine executing the decisions by the Arbitrator. Nevertheless, the Arbitrator works on the assumption that the 5GT-SO does its best to resolve resource shortages by scaling in underutilized VNFs, migrating VNFs within placement constraints, and acquainting additional resources via federation.

A vertical may agree with the 5G-TRANSFORMER service provider on a budget for resources of its VSIs. The resources considered so far are storage, memory, bandwidth, and processing. When a new vertical service is instantiated, the Arbitrator checks whether sufficient resources are left in the budget of the vertical. If not, the vertical is informed and can decide whether to continue nevertheless or whether to cancel the vertical instantiation. When going ahead the Arbitrator assigns resources to the VSIs based on priorities. The priorities of the VSIs are defined by the vertical itself. In total, there are still insufficient resources for all VSIs of a vertical, so the KPIs of some VSI will degrade. The Arbitrator ensures that low-priority VSIs experience the KPI degradation, whereas high priority ones continue to operate as usual.

The Arbitrator works on NSDs translated from VSDs. In these NSDs the service requirements have been translated already to information in deployment flavours (DF). The DF contain information such as bandwidth of virtual links, needed amount of CPUs, etc. The Arbitrator takes this information as input and modifies DFs or creates new ones according to its arbitration decisions.

Algorithms for arbitration and modifying DFs have been designed by UC3M, NXW, POLITO, and ITRI. The algorithms assign storage and memory resources to VSIs simply according to priority. For bandwidth and processing this is more complex. Eventually a required service latency needs to be satisfied, which consists of the

processing time and the network travel time. These times depend on the placement decisions done by the 5GT-SO, which are not known to the 5GT-VS. Therefore, the Arbitrator determines two DFs, one for a ‘best-case’ placement, where all VNFs are placed in one data center and network travel time is assumed to be zero, and another one for a ‘worst-case’ placement, where VNFs are placed in different data centers and substantial network travel time occurs. The Arbitrator extends the NSD with both DFs and passes them to the 5GT-SO when instantiating the service, asking for the best-case DF to be used by default. Nevertheless, depending on available resources, the 5GT-SO may use the other DF.

As an example, in the worst case, the Arbitrator assumes each VNF of a VSIV is deployed in a different server, thus implying the need for bandwidth allocation. Specifically, the allocated CPU,  $\mu^w$ , and bandwidth,  $\beta^w$ , now should satisfy the following constraints:

$$\sum_{v \in V} \frac{1}{f_v \mu^w - \lambda_v} + \sum_{(u,v) \in E} \frac{d_{v,w}}{f_{u,v} \beta^w} \leq D_s$$

$$\mu^w \leq C ; \beta^w \leq B$$

where  $f_{(u,v)}$  is the relative bandwidth requirement for the VL connecting VNFs  $u$  and  $v$ . Also,

- the first inequality accounts for the latency due to both the VNF execution and the travel time over the VLs connecting any two adjacent VNFs ( $E$  denotes the set of edges in the VNFFG). In other words, sufficient processing resources and bandwidth are provided to keep the sum of processing times and network travel time within the required limits;
- the second and third inequalities impose that both the total CPU and bandwidth allocations do not exceed the corresponding budget available to the vertical.

In addition to the algorithms for resource assignments, partners have investigated various other algorithms:

- Translation from VSD to NSD with DF parameters (NXW).
- Arbitration decisions about sharing of network slices (NXW).
- Preventing resource shortage at the Arbitrator (ORANGE, POLITO).
- VNF forwarding graph placement (BCOM).
- Three-layer network optimization algorithms for VNF placement in MEC integrated architectures (UC3M).
- Planning tool evaluation for planning of network slices on 5GT-VS level (TID).

#### 4.2.3.3 Task 3.3: Vertical service implementation

In this task WP3 provides implementations of components and functionalities to support verticals in the implementation of vertical services and to integrate the vertical services in an orchestration environment and WP3 provides the implementation of the 5GT-VS.

BCOM, NXW, and POLITO provided the architecture of the 5GT-VS, see Figure 7. The 5GT-VS interacts with verticals and MVNOs through a Vertical front-end component to select VSBs, define VSDs, and request lifecycle operations on vertical services. The

5GT-VS interacts as well with an enclosing Operating/Business Support System (OSS/BSS) to define tenants and resource budgets and to onboard the VSBs.

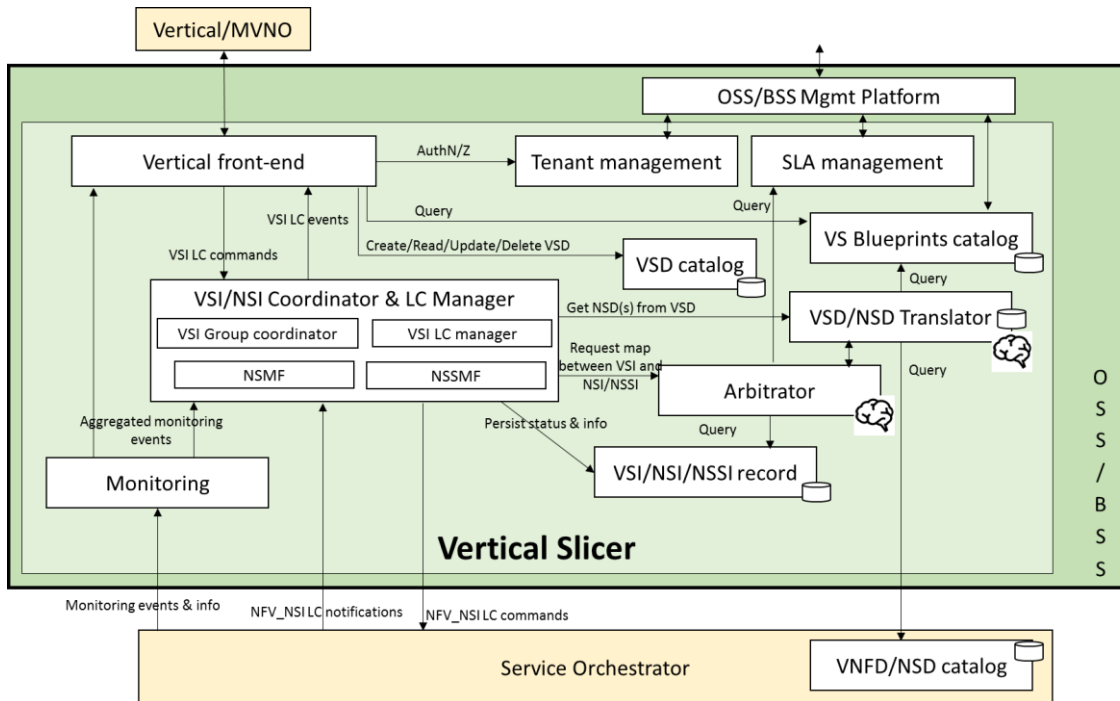

**FIGURE 7: THE VERTICAL SLICER ARCHITECTURE**

The lifecycle (LC) of VSIs and the corresponding NSIs are handled through the component called “VSI/NSI Coordinator & LC Manager”. This component implements the central engine of the 5GT-VS: it manages the association between VSIs and NSIs, handles the finite state machines for VSIs and NSIs lifecycle, coordinating commands and events associated to them. The network slice management is handled through requests for instantiation, modification and termination of the corresponding NFV-NSs, interacting with the 5GT-SO. The status and the current characteristics of VSIs and NSIs are stored persistently in the VSI/NSI records.

While the “VSI/NSI Coordinator & LC Manager” manages the lifecycle of slices and services, the complete 5GT-VS decision logic is implemented in the VSD/NSD Translator and in the Arbitrator. The VSD/NSD Translator selects the descriptors of the NFV network services able to support the requested vertical services. It identifies the DF most suitable to guarantee the performance and the characteristics of the VSD. The Arbitrator decides about the sharing of network slices among different vertical services and the resource assignment of vertical services based on service priority and resource budget in verticals’ SLAs.

The 5GT-VS Monitoring Service collects monitoring data to produce metrics and KPIs for NSIs and VSIs. These metrics can be used as input for SLA verification or to make decisions about the lifecycle of a network slice, for example triggering a scale up action in case of decreasing performance.

BCOM, NXW, and POLITO also defined the north- and southbound interfaces (NBI, SBI) of the 5GT-VS. Whereas the SBI is based on ETSI NFV IFA013 [12] with slightly extended NSDs, the NBI has been defined as two reference points: (see Figure 8):

- **Ve-Vs**, between a vertical and the 5GT-VS. This reference point provides the mechanisms to allow the vertical to retrieve VSBs, to manage VSDs, to request operational actions on VSIs, like instantiation, termination, modification, and to monitor performance and failures of instantiated vertical services.
- **Mgt-Vs**, between the OSS/BSS Management Platform and the 5GT-VS. This reference point provides primitives to manage tenants, SLAs and VSBs. It is used mainly for management and administrative issues and it is handled internally within the 5G-TRANSFORMER service provider.

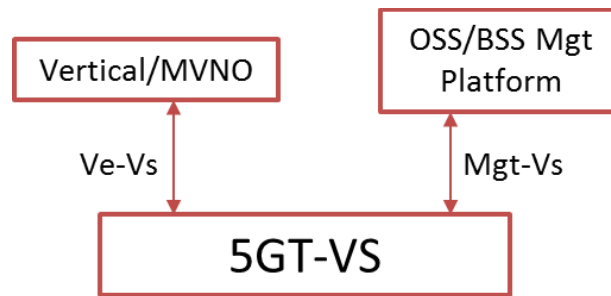

**FIGURE 8: REFERENCE POINTS OF THE 5GT-VS NBI**

The Ve-Vs reference point identifies the following operations:

- Query VSBs.
- Create, query, update, and delete VSDs.
- Instantiate, query, terminate, modify VSIs.
- Notifications about vertical service lifecycle events.
- Query monitoring parameters for VSIs.
- Subscriptions/notifications about vertical service monitoring parameters.
- Notifications about vertical service failures.

As an example, see the Query VS blueprints operation in Table 8. This operation allows a vertical to retrieve one or more VSBs from the 5GT-VS catalogue.

**TABLE 8: QUERY VS BLUEPRINTS MESSAGES**

Message	Direction	Description	Parameters
Query VS blueprint request	Vertical → 5GT-VS	Request to retrieve one or more VSBs matching the given filter.	• Filter (e.g. VSB ID, ...) Vertical ID.
Query VS blueprint response	5GT-VS → Vertical	Response including the details of the requested VSBs.	• List<VSB>.

The Mgt-Vs reference point between the OSS/BSS Management Platform and the 5GT-VS identifies the following operations:

- Create, query and delete tenants.
- Create, query, modify and delete SLAs.
- Create, query and delete VSBs.

The architecture of the 5GT-VS as described above and in more detail in D3.1 [4] is suitable to support the definition and instantiation of vertical services as well as handling the NFV infrastructure as a service (NFVlaaS) and network slice as a service (NSaaS) use cases. The architecture can be used as well in the context of MEC. NXW

and EURECOM investigated the impact of MEC on the 5GT-VS. This impact is limited to the addition of AppDs to NSDs, see Section 4.2.3.1, and to include references to the MEC Platform in VSBs.

The operations at the 5GT-VS NBI trigger sequences of operations within the 5GT-VS and at the 5GT-VS SBI. NOK-N, ATOS, and EURECOM defined corresponding workflows for operations such as Onboarding VSBs, defining VSD, and instantiating vertical services both on system level (in D1.2 [2]) and on the component level of the 5GT-VS (in D3.1 [4]). As an example, see the workflow for creating a VSD from a VSB in Figure 9.

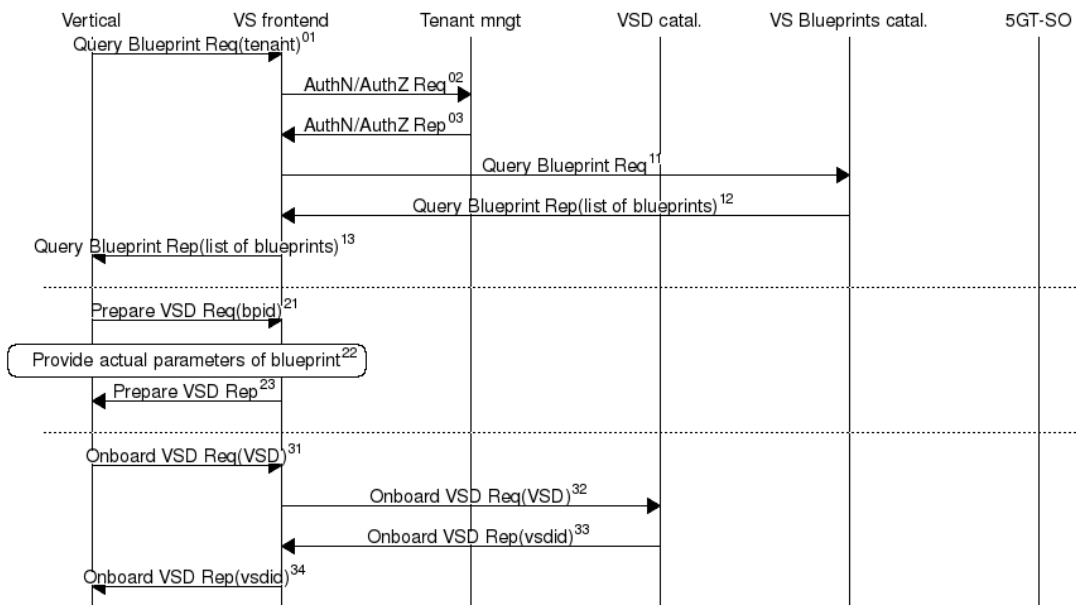

**FIGURE 9: WORKFLOW FOR VSD PREPARATION**

The use of the workflows to validate the 5GT-VS architecture has been complemented by an analysis of SLA management in a slicing environment (TID).

The implementation of the 5GT-VS has been started by NXW and ITRI with a first demonstration shown at EUCNC 2018. This version of the 5GT-VS provides basic functionality: it allows to select a VSB of a simple vertical service, create a VSD, instantiate the vertical service and pass the NSD to a service orchestrator. The implementation of the corresponding NFVO driver to connect to the 5GT-SO developed in WP4 has been started by ATOS.

The requirements on monitoring within the 5GT-VS and the corresponding interfaces have been defined by NXW. In addition to the support of monitoring within the 5GT-VS, the applications need to support monitoring as well. Here, NOK-N has started the implementation of a real-time monitoring probe. This is a virtual machine measuring the accuracy of time operations. This allows to assess verticals from within virtual machines to determine whether applications requiring real-time computations have been deployed by the 5GT-SO and 5GT-MTP to suitable hosts.

#### 4.2.3.4 Deviations

Overall, the work package is proceeding as planned. There are changes for two partners regarding the effort they plan to spend within WP3. EURECOM is shifting 5PM related to MEC from WP3 to WP2. Vice versa, NXW is shifting 5PM from WP4 to WP3 to widen the scope of the 5GT-VS implementation.

#### 4.2.3.5 Corrective actions

No corrective actions needed.

#### 4.2.4 WP4

WP4 focuses on the design and development of Service Orchestrator (5GT-SO). On the one hand, the 5GT-SO offers the 5GT-VS (and ultimately the different verticals accessing the system) services and/or resources across single administrative domains or federated administrative domains. On the other hand, the 5GT-SO exploits either (i) a mobile transport and computing platform (5GT-MTP) in order to deploy services and expose abstracted (virtual) resources, or (ii) federated service orchestrator(s). The design of the 5GT-SO internal architecture has been aligned with the 5G-TRANSFORMER system architecture design in the WP1 and described in D1.2 [2].

##### 4.2.4.1 Task 4.1: Service Orchestration

This task focuses on the design of 5GT-SO by defining its main functionalities and architecture, as well as developing orchestration algorithms for both service and resource orchestration. The main achievements of this task in the first period include:

- Design of the internal architecture of the 5GT-SO;
- Specification of essential operations, procedures and workflows;
- Design of interfaces and APIs for the 5GT-SO NBI towards the 5GT-VS, the 5GT-SO SBI towards the 5GT-MTP, and the EBI/WBI towards federated service orchestrators.

##### *5GT-SO Architecture and Key Operations*

SSSA, as the task leader, led the architecture discussions together with the partners in T4.1 (UC3M, NECLE, ATOS, ORANGE, NXW, MIRANTIS, CTTC, POLITO, EURECOM) during the weekly meetings as well as through face-to-face discussions in the plenary meetings done so far.

The functional architecture of the 5GT-SO defined in this first period is shown in Figure 10. The 5GT-SO design follows ETSI NFV guidelines [9] and is in line with orchestration system designs developed in related EU projects (i.e., 5GEx [10] and 5G-Crosshaul [11]). The main building blocks comprising 5GT-SO are the following:

- **NBI Exposure Layer:** This layer offers a Northbound API towards the 5GT-VS to support requests for service on-boarding, service creation, service instantiation, service modification, and service termination.
- **NFV-NS/VNF Catalogue DB/Manager:** Catalogue DB is the repository of all usable Network Service Descriptors (NSDs) and VNF Descriptors (VNFDs) that can be accessed through the Catalogue Manager. A NSD describes a Network Service (NFV-NS) that 5GT-SO is able to provision (either by its own or by leveraging neighboring SOs); and it is expressed in terms of chaining of VNF components and providing description of their connectivity (i.e., virtual links) and resource requirements. A VNFD describes a VNF in terms of its deployment and operational behavior requirements. The NSD/VNFD is used by the 5GT-SO in the process of NFV-NS/VNF instantiation and its lifecycle management to obtain relevant information, e.g., deployment flavors or out-scaling rules. The Catalogue Manager also takes care of the advertising of NFV-NSs for federation purpose.

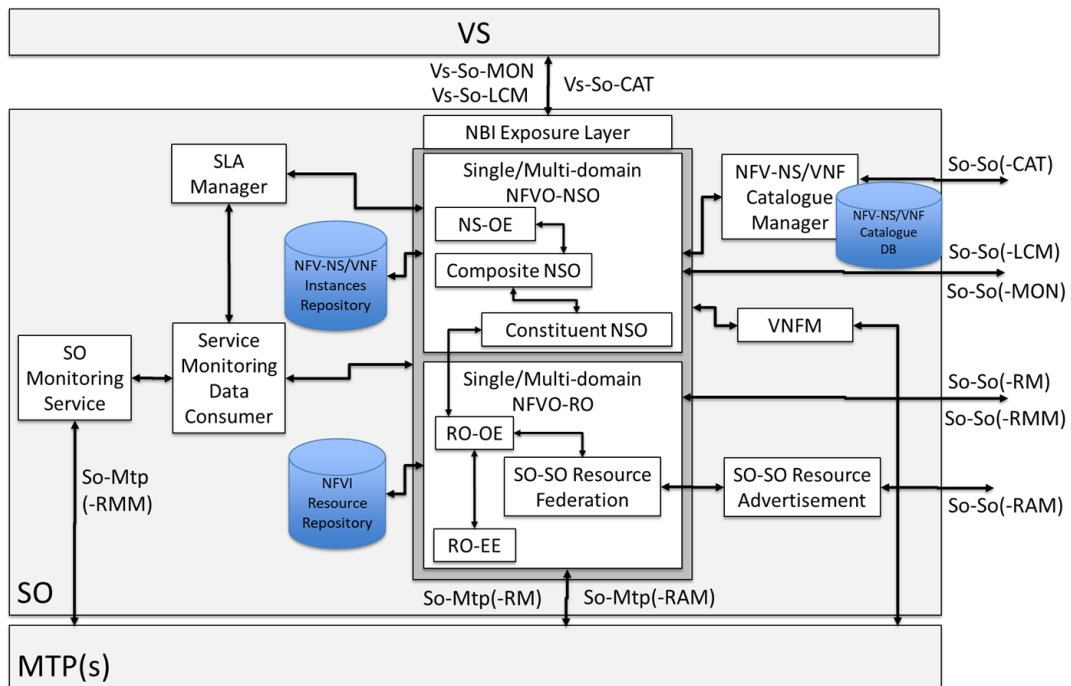

**FIGURE 10: 5GT-SO SYSTEM ARCHITECTURE - BUILDING BLOCKS AND THEIR INTERACTIONS**

- **NFV Orchestrator (NFVO):** NFVO has the responsibility of orchestrating virtual resources across multiple domains, fulfilling the Resource Orchestration (NFVO-RO) functions, as well as of coordinating the deployment of NFV-NSs along with their lifecycle management, thus fulfilling the Network Service Orchestration (NFVO-NSO) functions. More specifically:
  - NFVO-NSO coordinates all the NFV-NS deployment operations including Authentication, Authorization and Accounting (AAA) as well as formal checks of service requests based on attributes retrieved from NSDs and VNFDs. In particular, the Composite NSO, using the algorithms implemented in the NFV-NS Orchestration Engine (NS-OE), decomposes the NSDs into several segments and decides where to deploy them, i.e., whether using a local 5GT-MTP or leveraging neighbor SOs. Accordingly, the Composite NSO requests (i) the Constituent NSO and then the local NFVO-RO to implement the NFV-NS segment into its administrative domain; and/or (ii) the federated NFVO-NSO to implement the NFV-NS segment(s) into the other administrative domains. Finally, the NFVO-NSO is responsible for the network service lifecycle management including operations such as service on-boarding, instantiation, scaling, termination, and management of the VNF forwarding graphs associated to the network services.
  - NFVO-RO maps the NFV-NS segment into a set of virtual resources through the RO Orchestration Engine (RO-OE) by deciding the placement of each VNF within the virtual infrastructure, based on specified computational, storage and networking (e.g., bandwidth) requirements. The decision is based on available virtual resources that are exposed by the 5GT-MTP via the So-Mtp Southbound Interface (SBI) or by other domains through the So-So/East-Westbound Interface (EBI/WBI). In the latter case, the sharing of



abstract views is needed to build-up a comprehensive view of resources available from different domains and is carried out by the SO-SO Resource Federation element. Then, the RO Execution Entity (RO-EE) takes care of resource provisioning by managing the coordination of correlated actions to execute/forward the allocation requests to either 5GT-MTP or to the 5GT-SO NFVO-RO of other domains.

- **VNF Manager (VNFM):** the VNFM is in charge of the lifecycle management of the VNFs deployed by the 5GT-SO using either local or remote resources (or a combination of thereof). It receives relevant VNF lifecycle events from the local NFVO and provides reconfiguration according to specified counteractions decided by the NFVO based on VNFDs (e.g., auto-scaling).
- **SO-SO Resource Advertisement:** This block is in charge of exchanging abstract resource views (e.g., abstract topologies, computing and storage capabilities) with other domains while feeding the 5GT-SO Resource Federation entity that consolidates inputs and stores federated resources into the NFVI Resource Repository.
- **NFVI Resource Repository:** This repository stores consolidated abstract resource views received from the underlying 5GT-MTPs, either from the So-Mtp Southbound Interface (SBI) or from the SO-SO Resource Federation block in case of abstract resource views received from other SOs/domains through the So-So/East-Westbound Interface (EBI/WBI).
- **NS/VNF Instance Repository:** This repository stores the instances of VNFs and NFV-NSs that have previously been instantiated.
- **SO Monitoring Service:** This block provides the measurement reports for the 5GT-SO to support 5GT-SO monitoring management including performance monitoring and fault management, based on the collected monitoring data provided by the 5GT-MTP.
- **Service Monitoring Data Consumer:** This block supports the lifecycle management of instantiated VNFs/NFV-NSs by collecting measurement reports from the 5GT-SO Monitoring Service and reports data to the NFVO (e.g., to trigger auto-scaling actions based on scaling rules in the NSD) and/or to the SLA Manager (e.g., to enable SLA on-line verification). Performance reports can be also used to trigger healing actions to recover from failures or service degradations. The aim is to adapt deployed services or provisioned resources while preventing service degradations due to the concurrent usage of resources from different services.
- **SLA Manager:** This block elaborates performance reports from the Service Monitoring Data Consumer during the service lifecycle and assures that the agreed SLAs are continuously satisfied through on-line SLA verification. In the event a requested SLA is not met, the SLA Manager may trigger scaling actions to prevent or recover from SLA violations.

The above functional modules support a number of essential operations in 5GT-SO. Namely, (1) detection of other SOs for federation, (2) Resource/Service capabilities advertisement, (3) deployment, (4) SLA assurance, and (5) Reconfiguration. According to these operations, we specified the workflows for a selected set of essential procedures, including: (1) Service On-boarding, (2) Service Instantiation, (3) Service Modification, (4) Service Termination, (5) Service Assurance, (6) Service Federation, (7) Resource Federation, and (8) NFV-NS instantiation when including MEC applications. These workflows show the interaction between the different components

in 5GT-SO internally, as well as between these and 5GT-VS, 5GT-MTP or external 5GT-SOs. The detailed workflows have been reported in D4.1 [5] Section 5.

### Interfaces

NXW, SSSA, CTTC and UC3M devoted their efforts to the design of interfaces of the 5GT-SO and their corresponding reference points for the NBI towards the 5GT-VS, the SBI towards the 5GT-MTP, and the EBI/WBI towards federated service orchestrators.

#### **Vs-So Interface**

The 5GT-SO NBI is the interface between the 5GT-VS and the 5GT-SO, based on the ETSI NFV IFA 013 interface (reference point *Os-Ma-nfvo* between the OSS/BSS and the NFVO in the NFV MANO architecture) [12]. This interface is used for: (i) network service lifecycle management and forwarding of information related to the status of the NFV network services; (ii) management of NFV NS Descriptors, VNF packages and PNF Descriptors (PNFDs); and (iii) monitoring of Network Service Instances (NFV-NSI).

The interactions between the 5GT-VS and 5GT-SO implement the three reference points: **Vs-So (-LCM - LifeCycle Management)**, **Vs-So (-MON - MONitoring)**, and **Vs-So (-CAT - CATalogue)**. The mapping between the three Vs-So reference points and the specific interfaces defined in the ETSI NFV IFA 013 is reported in deliverable D3.1 [4], together with the required extensions in terms of descriptors' information model (e.g. in support of MEC applications integrated in NFV-NSs) and interfaces' information elements (e.g. in support of geographical or latency constraints specification).

#### **So-Mtp Interface**

The 5GT-SO Southbound Interface (SBI) addresses the interworking between the 5GT-SO and the 5GT-MTP building blocks of the 5G-TRANSFORMER architecture. It is worth mentioning that the 5GT-SO and 5GT-MTP may follow a 1:N relationship. That is, a single 5GT-SO may interact via multiple SBI instances with N MTPs which handle the configuration and programmability of a number of domains including heterogeneous virtualized resources for compute, storage and networking. The 5GT-SO SBI is based on the following reference points, mostly related to ongoing standard document produced within the ETSI NFV, namely, ETSI GS-NFV IFA 005, IFA 006 and IFA 008 [13] [14] [16]: **So-Mtp(-RAM)**, **So-Mtp(-RM)**, **So-Mtp(-RMM)** and **So-Mtp(-VNF)**. For more details, refer to D2.1 [3] and D4.1 [5].

#### **So-So Interface**

The 5GT-SO provides the interface to another external 5G-TRANSFORMER system. Therefore, the eastbound/westbound interface (EBI/WBI) of the 5GT-SO is as well the EBI/WBI of the 5G-TRANSFORMER system. Six reference points are defined at the EBI/WBI of the 5GT-SO, which are based on ETSI NFV IFA 013 and ETSI NFV IFA 005: **So-So(-Life Cycle Management)**, **So-So(-MONitoring)**, **So-So(-Catalogue)**, **So-So(-Resource Management)**, **So-So(-Resource Monitoring Management)**, and **So-So(-Resource Advertising Management)**. For more details, refer to D2.1 [3] and D4.1 [5].

#### **4.2.4.2 Task 4.2: Service-aware Monitoring**

This task is in charge of the design and implementation of a flexible monitoring platform for end-to-end infrastructure services to support the management of vertical services at the run-time. NXW, as the task leader, leads this task with the support of the partners in T4.2 (UC3M, NECLE, ATOS, ORANGE, NXW, MIRANTIS, CTTC, EURECOM, SSSA, ITRI).

The main achievements of this task in the first period include:

- Collecting and analysis of the monitoring requirements from all the 5G-TRANSFORMER use cases;
- Definition of monitoring service;
- Design of the 5GT-SO monitoring platform

### Monitoring requirements

Since the 5G-TRANSFORMER Monitoring Platform has the objective of supporting the management of the vertical services at run-time, the project has designed the 5G-TRANSFORMER monitoring platform starting from analysis of the monitoring requirements of the use cases studied in WP1 in D1.1 [1].

In order to collect the monitoring requirements from the different use cases, NXW has proposed a common methodology to identify the monitoring-related requirements for all use cases, with particular focus on “which kind of monitoring data” and “which kind of processing” are needed. The detailed analysis of the monitoring requirements for the different use cases, namely automotive use case, entertainment use case, e-Health use case and e-Industry use case, have been provided in D4.1 in Annex II [5].

The result of this analysis has allowed to identify not only the functional requirements of the monitoring platform (e.g. which parameters must be monitored and how), but also its non-functional requirements (e.g. how much storage is required? What is the frequency for notifications or polling mechanisms?). Based on this analysis, NXW has generalized the requirements for the entire monitoring platform and derived a high level design of the monitoring framework compatible with the main architectural principles and business roles defined for the whole 5G-TRANSFORMER system. This framework is described in the following.

### Monitoring Service

The 5GT-SO Monitoring Service is in charge of producing monitoring reports related to the performance or to failure events associated to the managed NFV network services and their VNFs. The generated monitoring reports can be used internally at the 5GT-SO, for example to validate SLAs or as triggers to auto-scaling procedures, according to the auto-scaling rules defined in the NSDs of the instantiated network services. Moreover, the monitoring reports produced by the 5GT-SO Monitoring Service can be also provided to the 5GT-VS through the Vs-So(-MON) reference point (see Section 4.2.4.1 for details).

The 5GT-SO Monitoring Service collects elementary monitoring data from different sources and correlates or aggregates them to global monitoring reports about the logical entities managed by the 5GT-SO, i.e. NFV network services and VNFs. Examples of performance metrics that can be elaborated at the 5GT-SO Monitoring Service are the amounts of vCPU or RAM consumed in a time interval by a specific VNF or by an entire network service, the number of packets lost on a virtual link, or VNF-specific indicators. The rules to correlate the elementary data received by the monitoring sources (e.g. vCPU consumption in single VMs as received by the 5GT-MTP Monitoring Service) are embedded in the monitoring algorithms. These rules allow obtaining the performance record for entire VNFs or NFV network service instances, as specified for the different metrics encoded in the NSDs.

### Monitoring Platform

To support the defined monitoring service for the 5GT-SO, NXW and MIRANTIS jointly proposed the design and implementation of the monitoring platform, depicted in Figure 11. At the southbound, the monitoring collector retrieves monitoring data from different monitoring sources through dedicated agents that translates between different information models, monitoring mechanisms or message protocols.

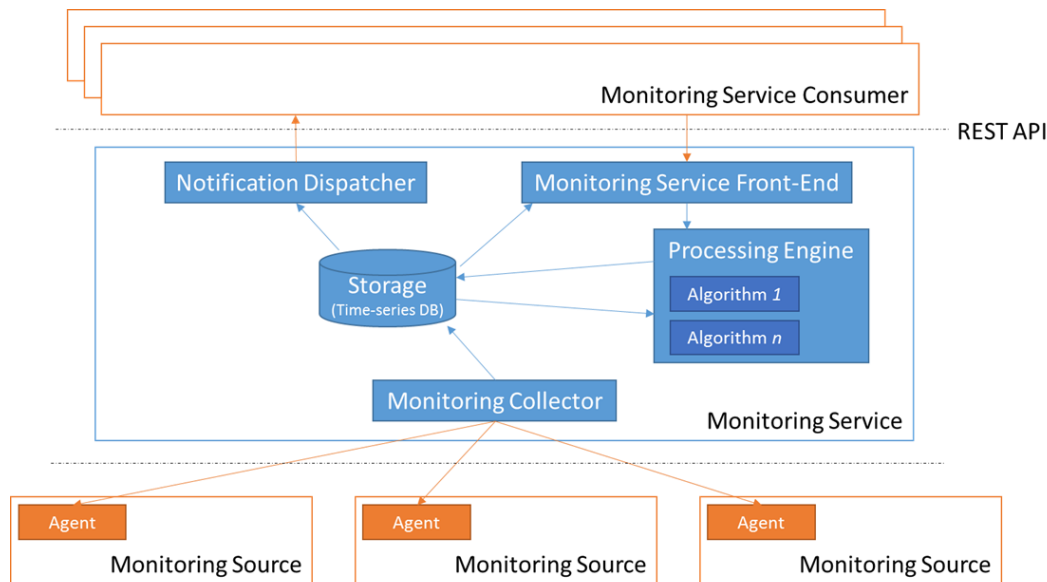

**FIGURE 11: FUNCTIONAL ARCHITECTURE OF THE 5GT-SO MONITORING PLATFORM**

In the 5GT-SO case, a number of interfaces are adopted to collect information from the different monitoring sources, as follows:

- The 5GT-MTP monitoring platform exposes monitoring data from VIMs and WIMs about virtual resources and, optionally, physical resources. This interface is based on the ETSI GS NFV-IFA 005 specification [13], which defines the reference points between NFVO and VIM.
- The federated 5GT-SOs' monitoring platforms expose monitoring data about nested network services or VNFs and virtual resources, depending on the type of service. In the NFV-NSaaS case the interface is based on the ETSI GS NFV-IFA 013 specification [12], while in the NFVlaaS case the interface is based on the ETSI GS NFV-IFA 005 [13] specification.
- The VNFMs expose VNF indicators collected by the VNFs or their EMs or VNFs' performance metrics. In this case the specific interface may vary with the target VNF. For example, it might be based on the ETSI GS NFV-IFA 007 specification [15], which defines the reference points between NFVO and VNFM, or, in case of proprietary VNFMs, proprietary protocols may be adopted.

The elementary monitoring data collected by these sources is then stored in the internal storage, typically a time-series DB to enable more efficient queries. These data can be used as input for further elaboration at the processing engine, which aggregates and correlates elementary data using specialized algorithms, according to the rules and filters specified by the monitoring service consumers. The post-processing data are also stored in the internal DB, so that they are made available for the consumers, which

can retrieve them through queries (through the Monitoring Service Front-End) or notifications (through the Notification Dispatcher).

The 5GT-SO Monitoring Service APIs should be compliant with the abstract messages defined in the ETSI GS NFV-IFA 013 reference point [12], with particular reference to the “NS Performance Management Interface” and the “NS Fault Management Interface”. The Performance Management Interface provides messages for creating, deleting and querying Performance Monitoring jobs (PMON jobs) as well as subscriptions and notifications to receive monitoring reports. The Fault Management Interface provides subscriptions, notifications and queries about alarms related to NFV network services’ and VNFs’ failures. Subscriptions and notifications can be also based on thresholds, in order to receive events only when a specific condition occurs. This is particularly useful to efficiently trigger NFV network service lifecycle commands, like scaling actions, to automatically react in case of performance degradation or SLA violation. Moreover, the ETSI GS NFV-IFA 013 [12] messages include several parameters to customize the desired behaviour of the monitoring platform, for example in terms of filtering and attributes selection in the queries, threshold specification, collection and reporting periods for monitoring threads.

It should be noted that the 5GT-SO Monitoring Service APIs are also used in the interaction between federated 5GT-SOs. In this case the APIs are used not only for monitoring of NFV network services and VNFs (at the So-So-MON reference point), but also for the monitoring of virtual resources provided by the peering administrative domain (at the So-So-RMM reference point).

To support the implementation of the proposed monitoring platform, MIRANTIS has given a detailed study of different OpenSource monitoring platforms and solutions. Based on this study, MIRANTIS and NXW have proposed Prometheus<sup>1</sup> for monitoring and Telegraf<sup>2</sup> for data collecting for the implementation of the 5G-TRANSFORMER monitoring platform. To support the different partners to use the monitoring platform, MIRANTIS has also provided a monitoring platform tutorial for the project. This tutorial includes exporters, Prometheus, Alert Manager deployment and configuration.

#### 4.2.4.3 Task 4.3: APIs and Service Federation

This task focuses on the design of federation mechanisms including the definition of the federation procedures, workflows, interfaces and APIs, as well as federation algorithms to provide end-to-end services and aggregate resources across multiple administration domains.

UC3M leads this task with the support of the partners in T4.3 (NECLE, TID, ORANGE, NXW, MIRANTIS, CTTC, EURECOM, SSSA, ITRI).

The main achievements of this task in the first period include:

- Definition of the federation mechanisms, related procedures and workflows;
- Design of the EBI/WBI towards federated service orchestrators;
- Starting the design of the federation algorithms.

#### Federation Mechanisms and EBI/WBI

Federation is a mechanism for integrating multiple administrative domains at different granularity into a unified open platform where the federated resources and services can

---

<sup>1</sup> <https://prometheus.io/>

<sup>2</sup> <https://www.influxdata.com/time-series-platform/telegraf/>

trust each other at a certain degree. An administrative domain is a collection of network services and resources operated by a single organization. The administrative domain is viewed as a single compact entity, where its internal structure is hidden or unimportant from outside. The resources and services inside the administrative domain operate with high degree of mutual trust among themselves, but the interaction with other administrative domains is subject to stringent trustworthiness constraints, with a default high level of alert. The federation is formed to increase the degree of trust among different administrative domains with a goal of better interoperability of services and resources. The embodiment of a service/business-level agreement or partnership between two administrative domains is a federation of trust [19].

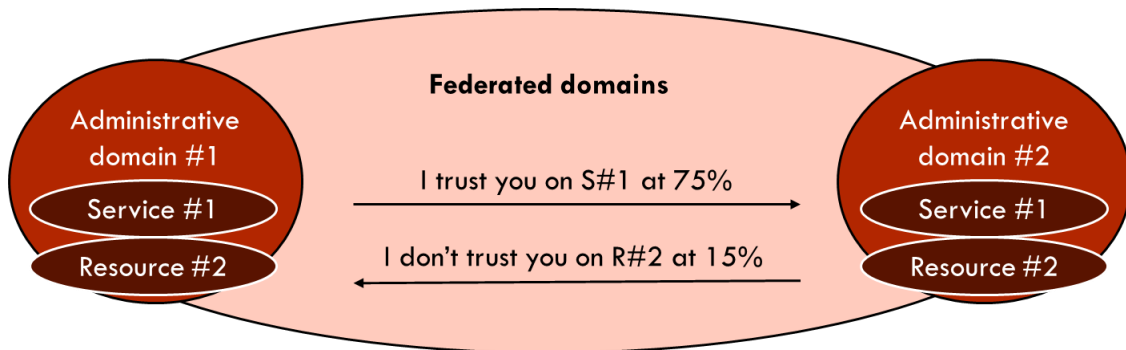

FIGURE 12: FEDERATION AS A DOMAIN UNIFIED BY MUTUAL TRUST [19]

In 5G-TRANSFORMER, the federation assumes already established business level and service level agreements. It is assumed that the complete relationship between external administrative domains is already defined. The federation levels are taken into account and the scope is on the technical level. In the architecture of 5G-TRANSFORMER, all federation procedures are executed on the 5GT-SO level using the EBI/WBI. More precisely, all external connections are established by the 5GT-SO via EBI/WBI (described in section 4.2.4.1).

We consider two types of federation:

- **Service federation** allows an administrative domain to request services that are instantiated and managed by other peering administrative domains. Service federation is corresponding to *Network Service as a Service (NSaaS)* for federation of services.
- **Resource federation** allows an administrative domain to request, use, and manage resources (including different types of resources, namely, networking, storage and computing resources) that are owned by other peering administrative domains. Resource federation is corresponding to *NFVI as a Service (NFVaaS)* for federation of resources.

The federation of services and federation of resources are two separate procedures that take place in different phases of the service instantiation/modification within the 5GT-SO. As shown in Figure 13, out of the six reference points composing on the EBI/WBI (as described in section 4.2.4.1), two are used for service federation and three for resource federation.

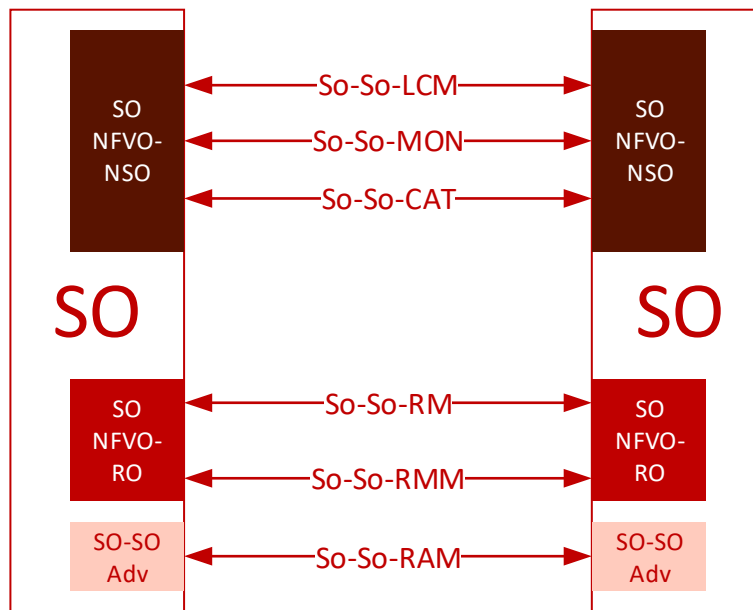

**FIGURE 13: 5GT-SO EBI/WBI REFERENCE POINTS**

The details on the proposed federation procedures and the corresponding workflows have been reported in D4.1 [5].

### Federation Algorithms

In the first period of the project year, the design of the federation algorithms has started with service/resource abstractions and specification of the high-level procedures that should be handled by 5GT-SO's algorithmic framework. This is work in progress, and the development of the algorithms is planned for the second period of the project.

For the services, abstractions (i.e., lower level of details) are applied already during the business negotiations. All information is hidden from a peering administrative domain. Once the provider 5GT-SO NFVO-NSO enables a federation of NFV network service to a consumer 5GT-SO, during the active phase it provides monitoring information with abstracted parameters and indicators. These abstractions do not reveal the underlying NFVI infrastructure, VNFs, PNFs, etc., that are enabling the federated NFV network service. The level of revealed details on the information exchanged/exposed between peering administrative domains depends on the agreed federation level according to the business/level agreements.

For the federation of resources, the abstraction is applied twice. First, the 5G-MTP applies resource abstraction on the underlying NFVI infrastructure. The abstraction applied in the 5GT-MTP Resource Abstraction block is applied to hide some details of NFVI resources from the local 5GT-SO. The second abstraction is applied upon calculation of federation capabilities in the 5GT-SO NFVO-RO. The 5GT-SO NFVO-RO reads information of available resources in the NFVI database (which are already generated and stored abstractions from the 5GT-MTP) and performs calculation. The outcomes of the calculations are categorized in federation levels. The categorized information is sent to the SO-SO Advertisement block. This block broadcasts the categorized resource abstractions to peering SOs according to the established federation level.

Another case of federation is when the whole process is dynamically created. The complete dynamical federation would consist of sharing service level agreements, establishing connections, initiating federation services or resources, lifecycle of federated services or resources. The realization of the dynamic approach can be centralized or distributed as explained in D4.1 [5].

#### 4.2.4.4 Deviations

Overall, the work package is proceeding as planned. There are changes for two partners regarding the effort they plan to spend within WP4. MIRANTIS gave the leadership to UC3M for the task T4.3, so as to focus the effort on the 5GT-SO implementation. Instead, NXW is shifting 5PM from WP4 to WP3 to widen the scope of the 5GT-VS implementation.

#### 4.2.4.5 Corrective actions

No corrective actions needed.

### 4.2.5 WP5

The main objective of this work package is to integrate the 5G-TRANSFORMER platform developed in WP2, WP3 and WP4 together with the different technologies available at the four test-beds available in the project and the proof of concepts (PoCs) established for the different use cases of the project. With this goal in mind, this WP is divided in three tasks with different objectives: the definition and setup of the vertical testbeds (T5.1), the integration of the platform and demonstration of the first PoCs (T5.2), and finally a task fully advocated to experiment and evaluate the results (T5.3).

#### 4.2.5.1 Task 5.1: Definition and set up of vertical testbeds

In T5.1 the main goal is to establish an initial planning for the integration between the four different testbeds of the project, namely: ARNO (in Pisa, Italy), 5TONIC (in Madrid, Spain), EURECOM (in Sophia Antipolis, France) and CTTC (in Barcelona, Spain), and the PoCs associated to the different UCs from the different vertical industries that are part of the project: Automotive, Entertainment, E-Health and E-Industry and also the MNO/MVNOs UCs. To achieve this goal, the work has been taken following two different directions. From one side the approach focused on describing the testbeds in terms of technologies, establish an initial plan for the integration among them and setup the physical connections that will support the integration. The other approach focused on describing the PoCs associated with the different UCs and establish a mapping between these PoCs and the technologies required from the testbeds and the functionalities required from the 5G-TRANSFORMER platform.

The result from the testbed description, as established by ERICSSON, UC3M, NECLE, SSSA, EURECOM and CTTC, is summarized in Figure 14, Figure 15, Figure 16, Figure 17, Figure 18 and Figure 19. For further details about the infrastructure of each testbed we refer to D5.1 [6].



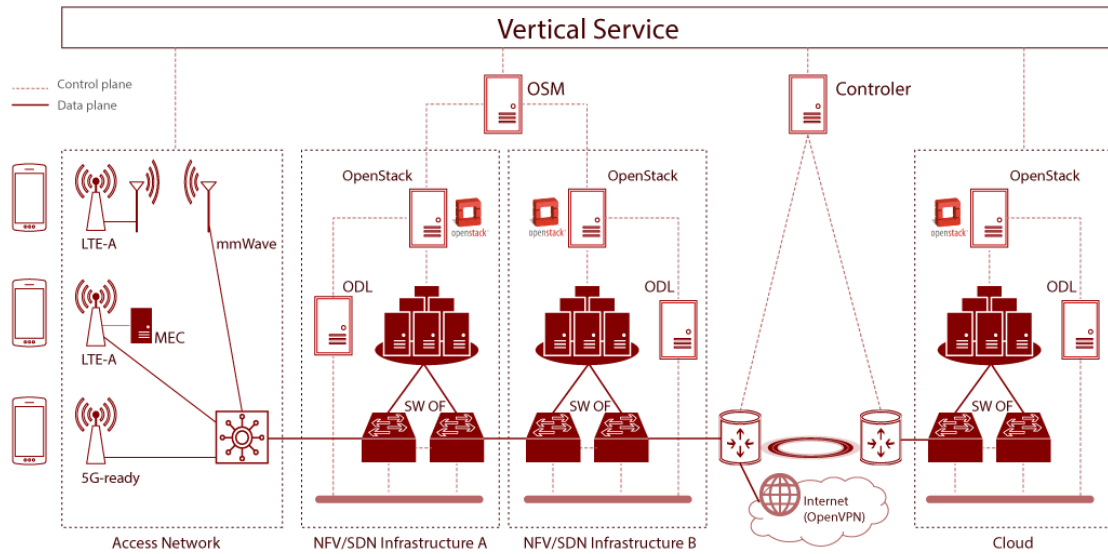

**FIGURE 14: 5TONIC INFRASTRUCTURE (PARTNERS INVOLVED: UC3M, ERICSSON, NECLE)**

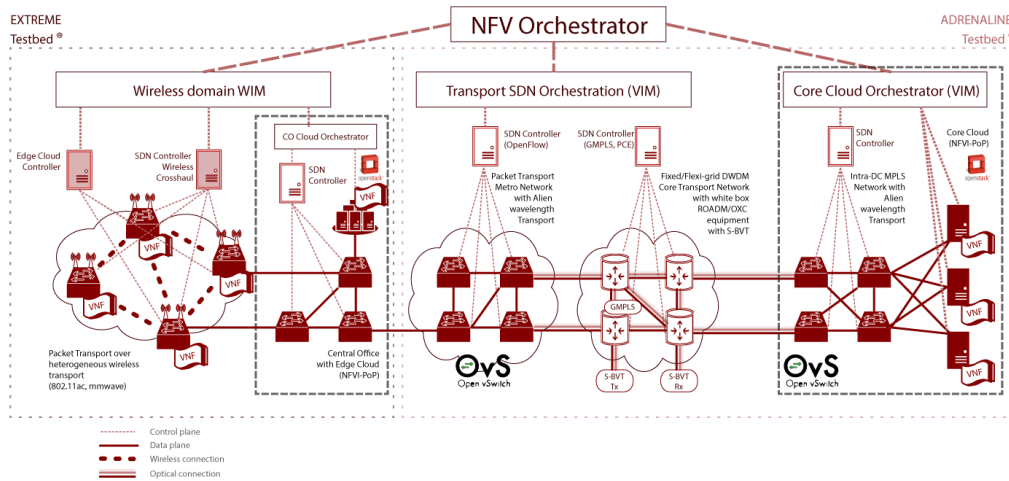

**FIGURE 15: CTTC TESTBED INFRASTRUCTURE (PARTNERS INVOLVED: CTTC)**

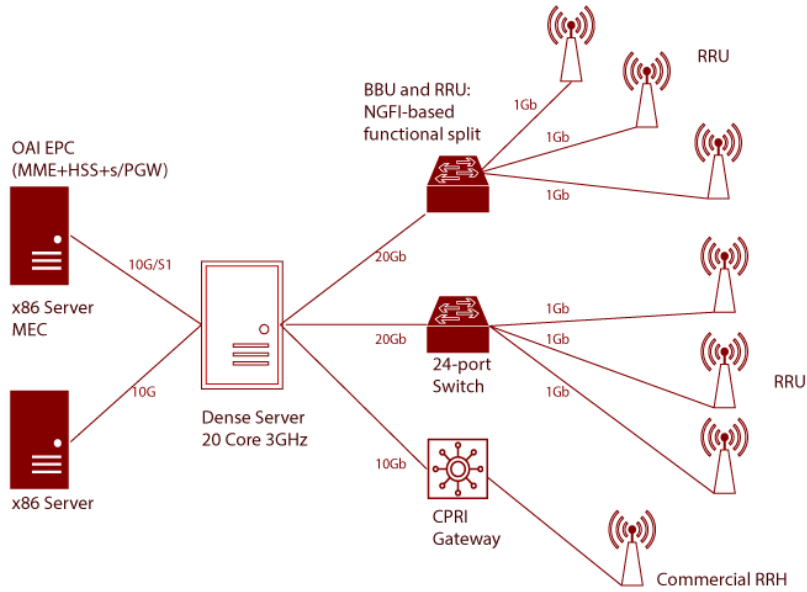

FIGURE 16: EURECOM INFRASTRUCTURE (PARTNERS INVOLVED: EURECOM)

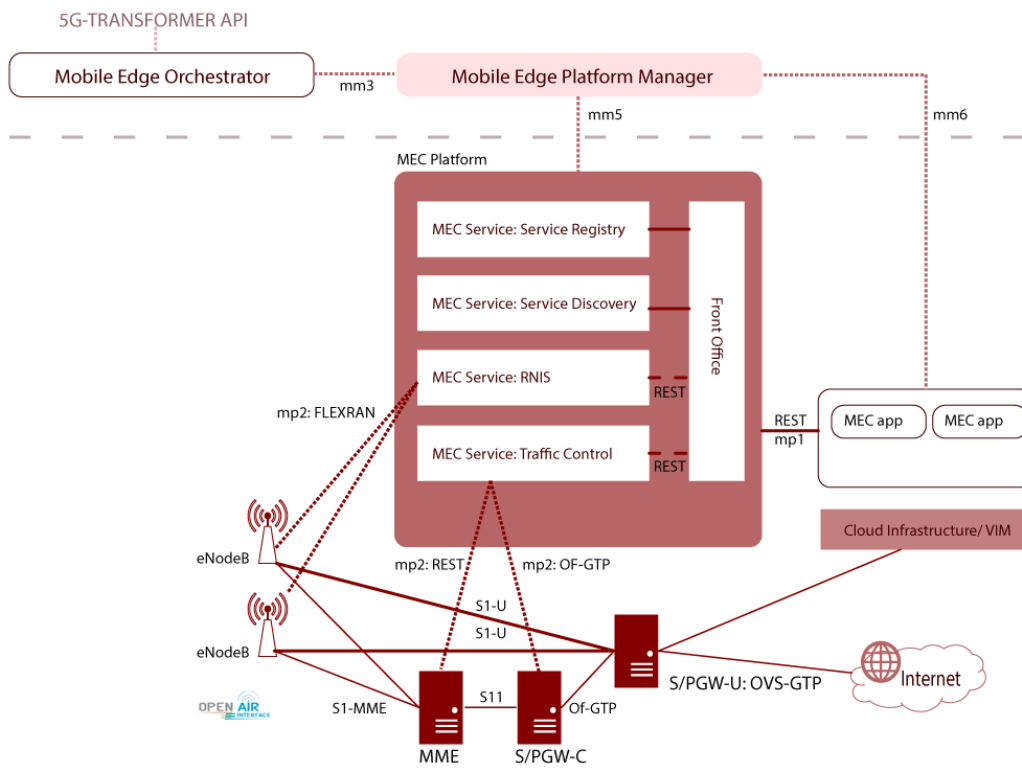

FIGURE 17: EURECOM MEC PLATFORM (PARTNERS INVOLVED: EURECOM)

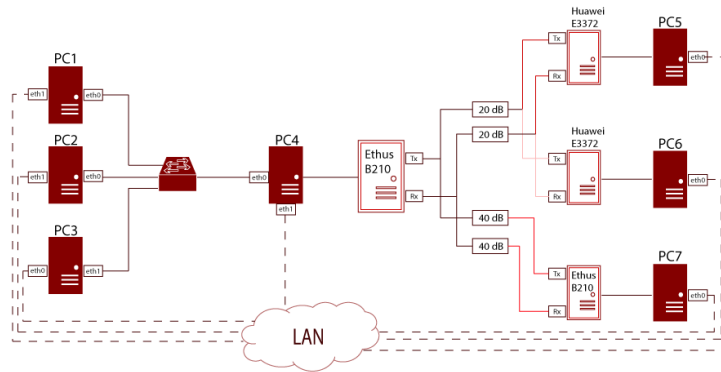

FIGURE 18: ARNO ACCESS (PARTNERS INVOLVED: SSSA)

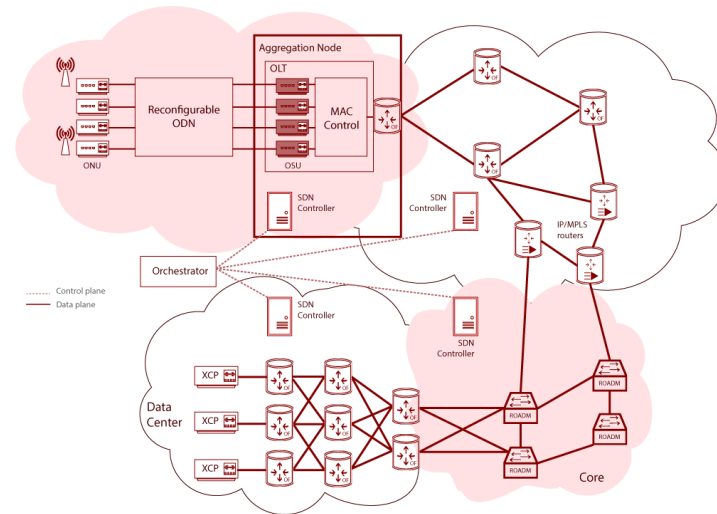

FIGURE 19: ARNO INFRASTRUCTURE (PARTNERS INVOLVED: SSSA)

In terms of technologies we obtained the set of technologies available in the integrated testbed as shown in Table 9 (please refer to D5.1 [6] for the technology identifiers). The first phase contains the technologies already available in the testbeds since M1, while the second phase shows the ones planned to be included after M18.

TABLE 9: INTEGRATED TESTBED TECHNOLOGIES (UC3M, SSSA, ERICSSON, NECLE, EURECOM AND CTTC)

ID	First phase (M1)	Second phase (M18)
<b>Heterogeneous</b>		
<b>T1.a</b>	USRP cards and OAI software, LTE-A microcells, virtualized EPC, mmWave base stations for fronthaul and backhaul traffic, user equipment for LTE-A. Spectrum licenses: 1.8(FDD-LTE), 2.6 (FDD-LTE), 3.5 (TDD-LTE), 2.4 and 5.2 (Wifi). Channel Bandwidth: 5MHz, 10MHz, and 20 MHz (FDD-LTE). C-RAN with Option 8 and Option7-1 functional splits support. Emulated IoT environment (InstantContiki). XGS-PON.	C-RAN (radio access with different functional splits), massive MIMO. Wireless transmission in unlicensed bands.

<b>Targeted Virtual Networks (VNF)</b>		
<b>T2.a</b>	OpenStack with different tenants. Not guaranteeing SLAs yet. RAN and EPC slice creation and instantiation using a customised version of OAI and a Slice Orchestrator. OpenFlow controllers (NOX/Floodlight/ODL/ONOS) OpenStack controller and XCP Virtual Machine Manager SONA framework for SDN-based OpenStack networking Orchestrators for cloud DCs and edge SDN networks. Reconfiguration/Orchestration in SDN network domains.	Integration with MANO. Plan to include joint orchestration across SDN and Cloud domains.
<b>T2.b</b>	VNFs implementing routers, firewalls, EPC and part of eNodeB. Service Function Chaining. NS-3 LENA modules (access and core) for mobile network emulation. A programmable RAN based on FlexRAN protocol (OAI-based). A SDN-based EPC architecture (split of S/P-GW: S/P-GW-C and S/P-GW-U). Virtualized DU, CU, and EPC via Virtualbox, KVM, Docker container.	VNFs implementing the different components of an EPC.
<b>T2.c</b>	ETSI OpenSourceMANO v2 as MANO controlling several OpenStack as the VIMs. Different SDN controllers (e.g., Ryu, ONOS, etc.) based on different implementations and relying on separated APIs (OFP, NETCONF/YANG) for heterogeneous switching capabilities and technologies. Shell-based flexible functional split (Option 8 to Option 7a) Reconfiguration/Orchestration in a single domain. Multidomain resource advertisement based on BGP-LS.	ETSI OpenSourceMANO v3 or beyond. Federation of testbeds. Interconnection (at some extent) of (two) Service Orchestrators. Flexible functional split (Option 8 to Option 7a) Reconfiguration/Orchestration based on Kubernetes in a single domain.
<b>T2.f</b>	End-to-end performance measurements for LTE and C-RAN (including core) with OAI	
<b>Cloud and Edge computing functions (CLD)</b>		
<b>T3.b</b>	MEC platform based on OAI. It implements mp1 (REST) and mp2 (FlexRAN and OpenFlow) interfaces. It provides the following MEC services: Traffic redirection, RNIS (a part), Service Registry and Service Discovery.	Enrich the RNIS API and integrate with a NFV MANO.
	OpenVPN to access the laboratory. ARNO testbed federated in Fed4FIRE through jFed where users can access LTE/C-RAN components.	

Enhanced privacy and Security Techniques (PRIV)	
T4.a	OpenVPN to access the laboratory. ARNO testbed federated in Fed4FIRE through jFed where users can access LTE/C-RAN components.
Broadcast and Streaming Functions (eMBB)	
T5.b	VNF SIP proxies
IoT Enabler Functions (mMTC)	
T6.a	WiFi Direct devices.

From the testbed integration perspective, in T5.1 we have also been working on an integration map that would enable us to demonstrate all the features from the project related to the physical infrastructure. In Figure 20 we show the initial testbed integration map. We have purposely omitted the names of the testbeds in this diagram, since this exact mapping is subject of further discussion as described at the end of this section.

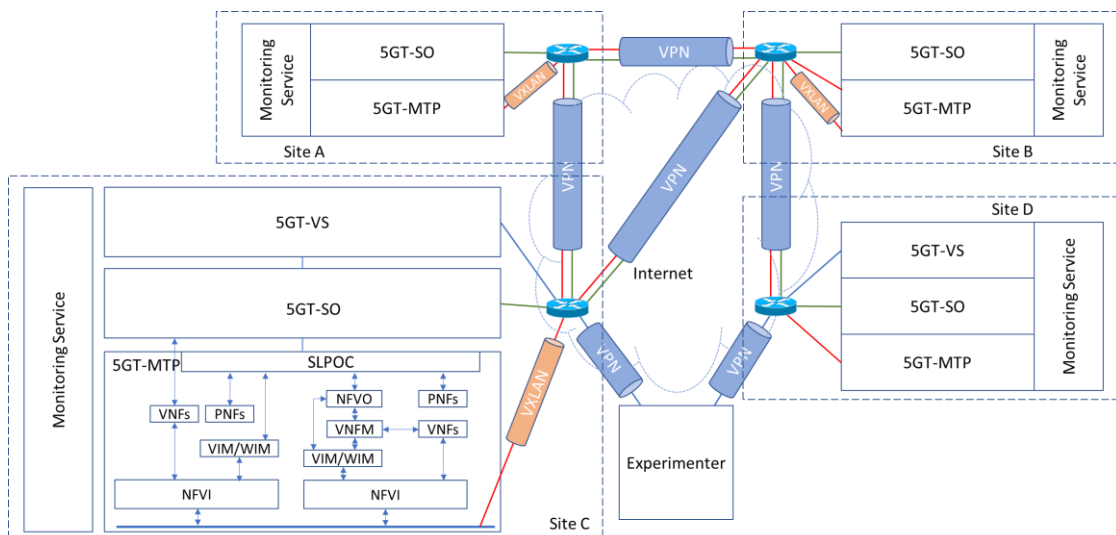

**FIGURE 20: TESTBED INTEGRATION PLAN (UC3M, SSSA, ERICSSON, NECLE, EURECOM)**

The second approach focused on understanding the expectations from the vertical industries, represented by: CRF, ATOS, SAMUR, TEI (with the support of NOK-N and UC3M) and the MNO/MVNOs represented by BCOM and ITRI. The outcome of this analysis is summarized in Table 10 as a set of functional requirements for the 5G-TRANSFORMER (also described in D5.1 [6]).

**TABLE 10: 5G-TRANSFORMER FUNCTIONAL REQUIREMENTS (ATOS, UC3M, CRF, BCOM, NOK-N, SAMUR, TEI)**

Id	Name	Description	Architectural components involved
FR1.	Federation	Seamlessly deploy a vertical service using resources or network services belonging to different administrative domains.	5GT-SO
FR2.	Vertical Service	Instantiate vertical services that	5GT-VS

	Composition.	use the instances of other vertical services.	
FR3.	Lifecycle management of vertical service.	Control the lifecycle of the vertical service.	5GT-VS
FR4.	Dynamic Changes of vertical service.	Give the VNFs/VAs composing the vertical service the possibility of scaling up/down the resources assigned to the service based on internal triggers.	5GT-VS
FR5.	Arbitration.	Automatic mechanism to act on resource outage based on vertical service priorities, etc.	5GT-VS
FR6.	Vertical service distribution across multiple Data Centers.	Integrate the resources and network services instantiated over multiple data centers.	5GT-MTP
FR7.	Lifecycle management of network slices.	Give the verticals the possibility of controlling the network slices associated to their vertical services.	5GT-VS
FR8.	SLA definition.	Define and enforce service level agreements.	5GT-VS, 5GT-SO
FR9.	Monitoring	Provide the verticals the capability of monitoring all the monitoring items associated to the vertical service.	5GT-VS, 5GT-SO, 5GT-MTP
FR10.	Orchestration-Placement	Provide the verticals the possibility of defining rules or algorithms that could influence the placement decisions.	5GT-VS, 5GT-SO
FR11.	Orchestration-Scaling	Provide the verticals the possibility of defining rules or algorithms that could influence the scaling decisions.	5GT-VS, 5GT-SO
FR12.	MEC Integration	Seamlessly integrate the MEC platform.	5GT-VS, 5GT-SO, 5GT-MTP

These functional requirements are aligned with the contributions of the project and identify which are the features that the partners are most willing to demonstrate. This set was also used in WP2, WP3 and WP4 to establish a release roadmap for the platform.

Finally, in T5.1 we used the UCs selected for demonstration (which are reported in D1.2 [2]), and described them in D5.1 [6] as a set of PoCs which are mapped to the technologies and functional requirements from Table 9 and Table 10. Table 11 summarizes the PoCs established in D5.1 by CRF, POLITO, NXW, Atos, SAMUR, UC3M, TEI, BCOM and ITRI.

**TABLE 11: 5G-TRANSFORMER PoCs**

PoC id	Description	Functionalities to be tested	Required technologies	Verification
<b>Automotive (CRF, POLITO, NXW)</b>				
1.1	The vehicle exchanges messages (CAM, DeNM) with a road-site unit (RSU) deployed on MEC host. A Video streaming service is deployed in the MEC host and delivered to the vehicle UE.	Slice creation and instantiation in MEC host, Data and control connectivity between vehicle and infrastructure. (FR2, FR12)	T1.a, T5.b	Required Traffic flows from the vehicle to the RSU.
1.2	CIM (in the MEC host) receives and processes messages from the vehicle and the traffic simulator	Slice creation and third party Application Server Instantiation	T3.b,T2.h, T2.c, T2.d	Required traffic flows between the MEC and all involved entities (including traffic simulator input to CIM).
1.2 plus	Integration of real radio equipment	Data plane connectivity among radio transport and cloud	T1.a, T1.d, T3.b,T2.h, T2.c, T2.d	Required E2E latency (radio protocol contribution between modem and SGi interface, transport contribution, SGi interface and MEC processing time of algorithm)
1.3	The Extended-Sensing in the MEC host processes context data from CIM and compute decision (special message) to be notified to the vehicle.	Car Maker Application Server Instantiation and configuration in the car maker slice	T2.b, T2.d, T2.f, T3.b	Communication between VAs in MEC host Required latency and impact of Extended-Sensing algorithm
1.4	In vehicles Integration + Backends (optional)	Cloud functionalities	T3.a, T2.i, T2.b, T2.d	End to End communication among all the service components
1.5	Increase the amount of connected vehicle	SLA Monitoring. Service	T2.d, T2.b, T2.f	Monitor the assigned

	and slices (for different services, e.g. video streaming). The slice instance resources should be increased to adapt to the new requirements.	Scaling, Service Arbitration (FR3, FR4, FR5, FR6, FR8, FR9)		resources.
<b>Entertainment (Atos)</b>				
2.1	A MEC platform is in place, and the platform instantiates the appropriate NSDs when the vertical service is requested. The spectator app requests an UHD video. The system provides the video feed to the app.	Network slice creation or instantiation. Data and control connectivity between the spectator app and a local video cache (FR12, FR3)	T1.a R, T1.d R, T2.a R, T2.b R, T3.b R, T4.a, T2.f R	Traffic flows from the system to the app.
2.2	Connect the Video Distribution service with a PNF providing live stream.	Physical Network Function connectivity.	T1.a R, T1.d R, T2.b R, T2.a R, T2.g,	Communication between the VA and the live stream.
2.3	Instantiate a separate vertical service (i.e providing video metadata), and connect it to the service instantiated in PoC 2.1	Connectivity between slices, Vertical Service composition. (FR2)	T1.a R, T1.d R, T2.b R, T2.a R, T2.c R	Traffic flows between all involved entities using the network slice.
2.4	Interconnection of a secondary datacentre for backup source.	Data plane connectivity between different DC. (FR6)	T1.a R, T1.d R, T2.b R, T2.a R, T1.c	Monitoring, Traffic flow between DC.
2.5	Instantiate the video service over multiple Administrative Domains.	Data plane connectivity between AD. (FR1)	T1.a R, T1.d R, T2.b R, T5.a R, T7.a R, T2.c R	Monitoring, Traffic flow between AD.
2.6	Increase the amount of connected devices. The service instance resources should be increased to adapt to the new requirements.	Service Aware Monitoring. Service Scaling. (FR8, FR9, FR10, FR11, FR4)	T1.a R, T1.d R, T2.b R, T2.d R, T2e R	Monitor the assigned resources.
<b>E-Health (SAMUR, UC3M)</b>				
3.1	The wearable transmits information towards the eServer, which analyse the information. When an issue is detected, the	Data and control connectivity between the wearable and the eServer,	T1.a R, T1.d R, T4.a R, T4.d	Wearable off and on → alarm and cancel. Wearable off → alarm and confirmation.



	eServer contacts the wearable to confirm or discards the alert.	data analysis, alert confirmations. (FR1, FR3, FR6, FR10)		
3.2	A MEC platform is deployed over the instantiated network slice.	MEC functionalities (FR8, FR12)	T3.b R	Required traffic flows between the MEC and all involved entities.
3.3	After an alarm is confirmed, the wearable starts searching for paramedics in the neighbour area. If any paramedic is found, a communication is established.	Device-to-device communication.	T6.a R	Communication between patient and paramedic devices is established.
3.4	After an alarm is confirmed, the eServer requests the configuration of a network slice among all involved entities is instantiated.	Network slice creation or instantiation. (FR4, FR5, FR9, FR11)	T2.a D, T2.b R, T2.c R, T5.b D, T7.a D.	Traffic flows between all involved entities using the network slice.
<b>E-Industry (TEI)</b>				
4.1	Preparatory experiment for cloud robotics (CR) service activation.	Traffic isolation. (FR8)	T2.a R, T2.b R	Verify the latency requirements and service isolation. This test will enable the network slice creation and instantiation in a next step.
4.2	CR service activation	Data plane connectivity among Radio Transport and Cloud (FR3, FR7, FR6)	T1.a R, T1.d R, T4.a R, T6.b R	Check if latency requirements are met in different virtualization scenario and different (v)EPC location.
4.3	Monitoring of failures on the transport domain	Monitoring of the transport domain for enabling recovery of degraded connectivity (FR9)		5G-MTP perform the monitoring for enabling recovery.
<b>MNO/MVNO (BCOM, ITRI)</b>				
5.1	MNO requests the instantiation of a specific 5G network	Network slice template provision (SLA)	T2.a R,	Vertical slicer order sent to 5GT-SO for network service

	with local access to the infrastructure, in a split vEPC mode	(FR8)		instance creation
5.2	End to end network slice set up and vEPC network service are instantiated, connected to local small cells and Wi-Fi APs.	Network slice/service instantiation. Multi-access CP/UP split. Access to local and central cloud. Interconnection with legacy MNO services (HSS at least) (FR1, FR2, FR3)	T1.a R, T1.d R, T2.a R, T2.b R, T2.f R, T2.c R.	VNFs are up and running
5.3	End-users are provided with multi connectivity (4G/5G/Wi-Fi), homogeneous QoE and unified authentication	Multi access, unified authentication	T2.b R, T4.a R, T2.f D	UE connectivity via Cellular access and WiFi access towards Internet
5.4	Direct access to local cloud allows end users to share and store their data locally with low delay and high bandwidth;	Local servers, applications (cache, CDN) (FR6, FR7)	T3.a R, T5.a D.	UE retrieve content cached in local Data Center
5.5	Monitoring allows troubleshooting operations	Virtualized monitoring (FR9)		Traffic probe instantiated, monitoring dashboard

The remaining effort in T5.1 will focus on further detailing the integration map between the testbeds, the PoCs and the functionalities from the platform. This discussion will involve all the testbed representatives and the partners contributing with the implementation of the UCs, and will consider: the PoCs established for the UCs, the result of the performance tests and the feasibility for the testbeds to embrace the different components of the architecture.

#### 4.2.5.2 Task 5.2: Integration and proof of concept

In T5.2, which started on M8, we first focused on establishing an integration plan which considers the PoCs (from Table 11) and the releases of the platform. The outcome of this is shown in Figure 21.

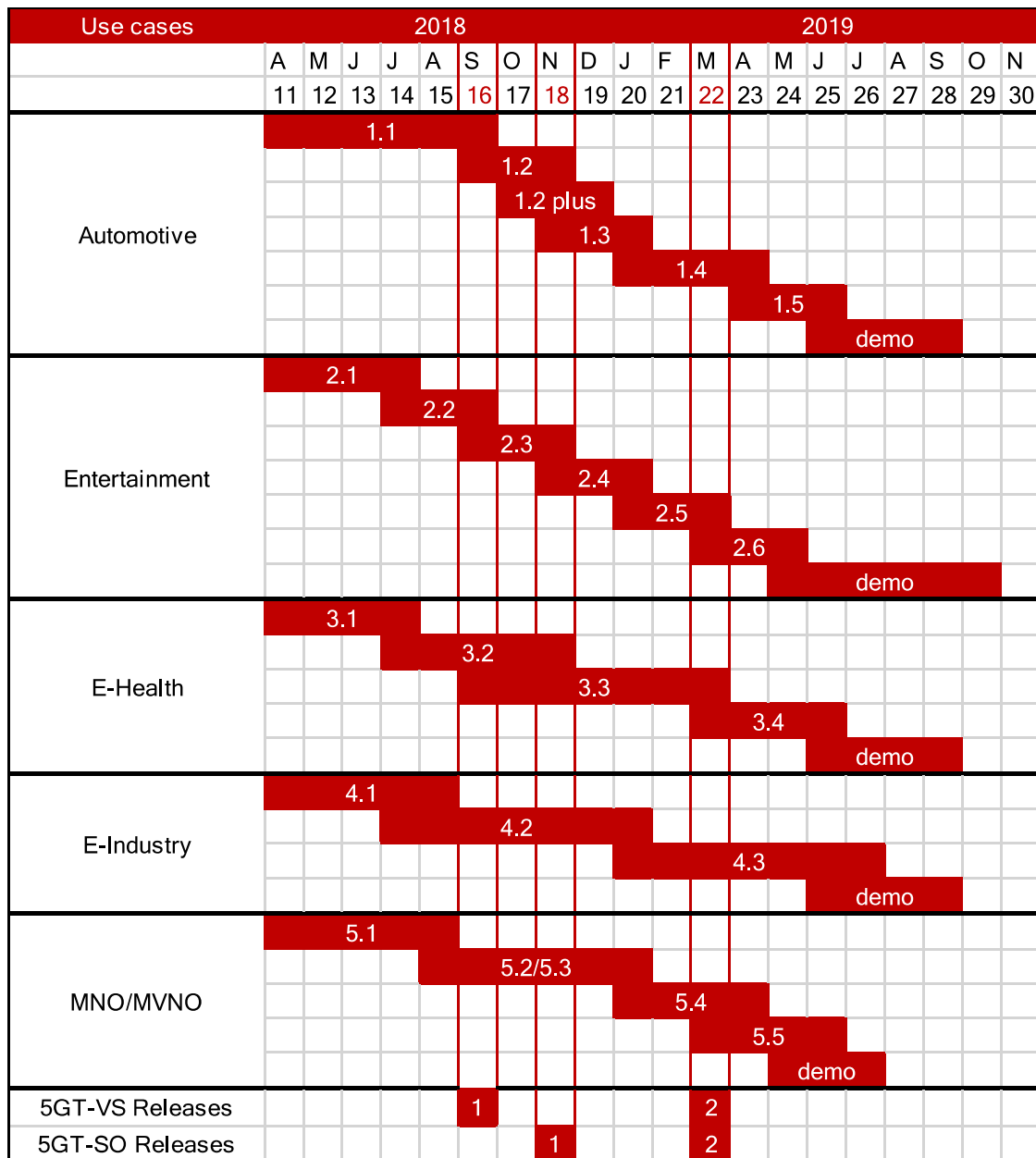

FIGURE 21: PoC SCHEDULING

With this schedule in mind, and using the release map from WP2, WP3 and WP4 we planned three demonstrations exhibited at the EuCNC 2018.

The first demonstration, involving NXW, ATOS and UC3M, aimed to show a prototype of the 5GT-VS running on top of the NFVO used in the 5G-Crosshaul project, to deploy the key components of the Entertainment UC of the project. The objective is to demonstrate how the 5GT-VS can translate the parameters of the vertical service into different network service descriptors. Particularly, the demo will show how the number of users can be used as a parameter to instantiate services with different amount of resources. In this case the number of users is used to determine the number of video caches in the edge of the network.

The second demonstration, presented by IDCC and EURECOM, at the EUCNC will show the application cases for the Radio Network Information Service (RNIS) with a focus on cloud robotics. We are demonstrating an LTE network where a robot equipped

with an LTE interface is attached to an OpenAirInterface eNodeB and EPC. The RNIS is exposed and applications can consume it over a REST API to retrieve, among others, run-time Channel Quality Indications (CQI) per UE. The RNIS collects this information from agents built into eNodeBs using the FlexRAN southbound protocol. The purpose of this demonstration is to show how applications can make the best of the RAN-level awareness offered by the RNIS for real-time adaptations, particularly focusing on cloud robotics scenarios.

Finally, the third demonstration, by MIRANTIS, ATOS and UC3M, used Cloudify (i.e. the platform chosen as reference for the 5GT-SO in WP4) to orchestrate the key components of the Entertainment use case using private and public clouds (5tonic and Amazon AWS respectively). The main goal is to demonstrate a custom plugin developed for Cloudify which can automatically provision the VPN endpoints and create the tunnels to connect different network clouds, and how a vCDN service can be built on top of this.

The next steps in T5.2 will be focused on the development of the PoCs of the UC, and use the output generated by the integration map in T5.1 to advocate the effort to prepare the testbeds.

#### 4.2.5.3 Task 5.3: Experimentation and evaluation

T5.3 started in M10 and aims to further detail how the different PoCs will demonstrate the KPIs established for the project. We refer to section 4.6.1 for details about the KPIs of the project and how these are mapped to the ones identified by the 5GPPP. The effort in this task, by ATOS, UC3M, SAMUR, TEI, CRF, ITRI, BCOM and SSSA, has been set on identifying which KPIs are most relevant for each UC (and the correspondent values) and setting a common methodology to collect the quantitative and qualitative information. Since this task is inherently related to the monitoring platform, we have been working in tight collaboration with the rest of the WPs to ensure a full support from the platform to collect the required information.

The demos at the EUCNC18 by ATOS, MIRANTIS and NXW, detailed in the previous section, already produced in terms KPIs: namely the service instantiation time, end to end latency and data rate (LAT, UDR and SER from Table 19). Once we finish with the process of mapping the KPIs to the UCs and establishing the methodology, we will focus on analysing if it is feasible to demonstrate KPIs not originally considered in the project.

#### 4.2.5.4 Deviations

In September 2017, Juan Brenes replaced José Enrique González as WP5 leader (both from ATOS).

#### 4.2.5.5 Corrective actions

No corrective actions needed.

### 4.2.6 WP6

As far as this project is concerned, and in accordance with common practice at the EU level [1],[8], *Communication* includes all the activities related with the promotion of the project and its results beyond the project's own community. This includes the interaction with other research projects (e.g., H2020 5G PPP) as well as communication of its research in a way that is understood by the non-specialist, e.g. the media and the public. Notice, though, that even if collaboration with other projects is presented under

communication, it also spans dissemination and exploitation. *Dissemination* includes activities related with raising awareness of its results in a technical community working on the same research field. In general, this will be done through publications, and participation and organization of technical events. Finally, *exploitation* (in accordance with the European IPR Helpdesk) covers activities aiming at using the results in further research activities other than those covered by the project, or in developing, creating and marketing a products or processes, or in creating and providing a service, or in standardization activities.

Though a brief global overview is provided in the following paragraphs, the detailed work carried out in WP6 is reflected in various sections throughout this document according to the template. Communication activities (i.e., the outcome of task 6.1) are presented in this section, Dissemination activities (i.e., the outcome of task 6.2) are presented in section 3, and Exploitation activities (including standardization) are presented in section 4.5, and are also as an outcome of task 6.2. Finally, section 5 refers to D6.2 [22] (just released) for an updated communication, dissemination, and exploitation plan (CoDEP) of 5G-TRANSFORMER.

In accordance with the communication, dissemination, and exploitation plan (CoDEP) presented in the DoA (see FIGURE 22), the first period of the project is mainly devoted to **raise awareness** about the scope and approach of 5G-TRANSFORMER. This phase starts with the preparation of communication material as well as the website and social media and ends with the demonstrations carried out at EUCNC'18 in the 5G-TRANSFORMER booth (which was prepared in cooperation with 5GEx and 5G-CORAL projects).

Therefore, task 6.1 has a starring role in this respect. In this direction, various project partners presented the project in various events, participated in coordination calls with other 5G-PPP projects and prepared the website and social media of the project. This allowed achieving the milestone set for M3 (August 2017), which also included the preparation of communication material, such as the leaflet and poster (and also a reference communication presentation). Since the project started, there has been a steady increase of the web and social media impact, for instance, reaching 4000 visits on the web or 32000 Twitter impressions.

Communication actions for society at large were also carried out. Various events were also co-organised by 5G-TRANSFORMER with other H2020 projects (most of them 5G-PPP ones). More specifically, the joint work with other 5G-PPP projects was carried out in various forms. Events organized during 2017 are: The O4SDI workshop, the 5G and automotive workshop, or one WWRF39 session. A workshop co-located with IEEE WCNC'18 (1<sup>st</sup> COMPASS) was also submitted, accepted and already took place on April 2018. A workshop co-located with IEEE BMSB'18 was also accepted (2<sup>nd</sup> COMPASS) as well as one at EUCNC'18 jointly with other 5G-PPP projects (Multi-provider, multi-vendor, multi-player orchestration: from distributed cloud to edge and fog environments in 5G). Additionally, 5G-TRANSFORMER also participates in the workshop organized at EUCNC'18 by the 5G-PPP Software Networks working group (From cloud ready to cloud native transformation: What it means and Why it matters). Finally, a PIMRC'18 workshop jointly organized with 5G-AURA was also accepted.

In addition to jointly organized events, the project is regularly participating in 5G-PPP working groups, and preparing joint papers. The project also regularly participates in 5G-PPP COMMS group, an activity organized by the To-Euro-5G CSA towards a joint

dissemination strategy of all 5G-PPP projects, and so, regularly exploits these joint channels.

Several talks (technical and general public), publications, student supervision, etc. were also given during this period.

As for dissemination and exploitation (task 6.2), several actions were also carried out. A number of papers (6 in Journals, 20 at conferences and 9 at workshops) were accepted and presented in international journals and conferences (e.g., IEEE Transactions on Mobile Computing, EUCNC, IEEE INFOCOM).

Furthermore, the participation of the project at the Mobile World Congress (MWC) held in Barcelona (26 Feb-1 Mar) is also relevant in this respect. Additionally, four demonstrations were presented at EUCNC, in a joint booth with 5G-Ex and 5G-CORAL, and one at IEEE INFOCOM 2018. A demonstration to the PSA group was also performed at 5TONIC premises.

Moreover, the first months were also devoted to refining the CoDEP originally presented in the proposal, with especial emphasis on the exploitation plan (incl. standardisation). A number of results in terms of standardisation were also achieved, since the ETSI MEC group approved the creation of a work item on “Slicing and Federation across distributed MEC platforms”, which was promoted by 5G-TRANSFORMER partners. Other standardization results were also obtained, from creation of new work items to publication of IETF drafts, to contributions to 3GPP. A standardization advisory committee (SAC) was specifically created to coordinate the work, continuously refine the roadmap and maximize impact. As part of these roadmap, a number of contributions, mostly to ETSI MEC and IETF working groups (e.g., NFVRG, CCAMP) were submitted. 16 contributions to four different SDOs: 10 to IETF, 1 to 3GPP, 4 to ETSI MEC, and 1 to NGMN.

Finally, let us also highlight that the project was granted all five services requested for the Common Dissemination Booster, jointly with other projects (5G-Crosshaul and 5G-Coral), which started its operation in May 2018.

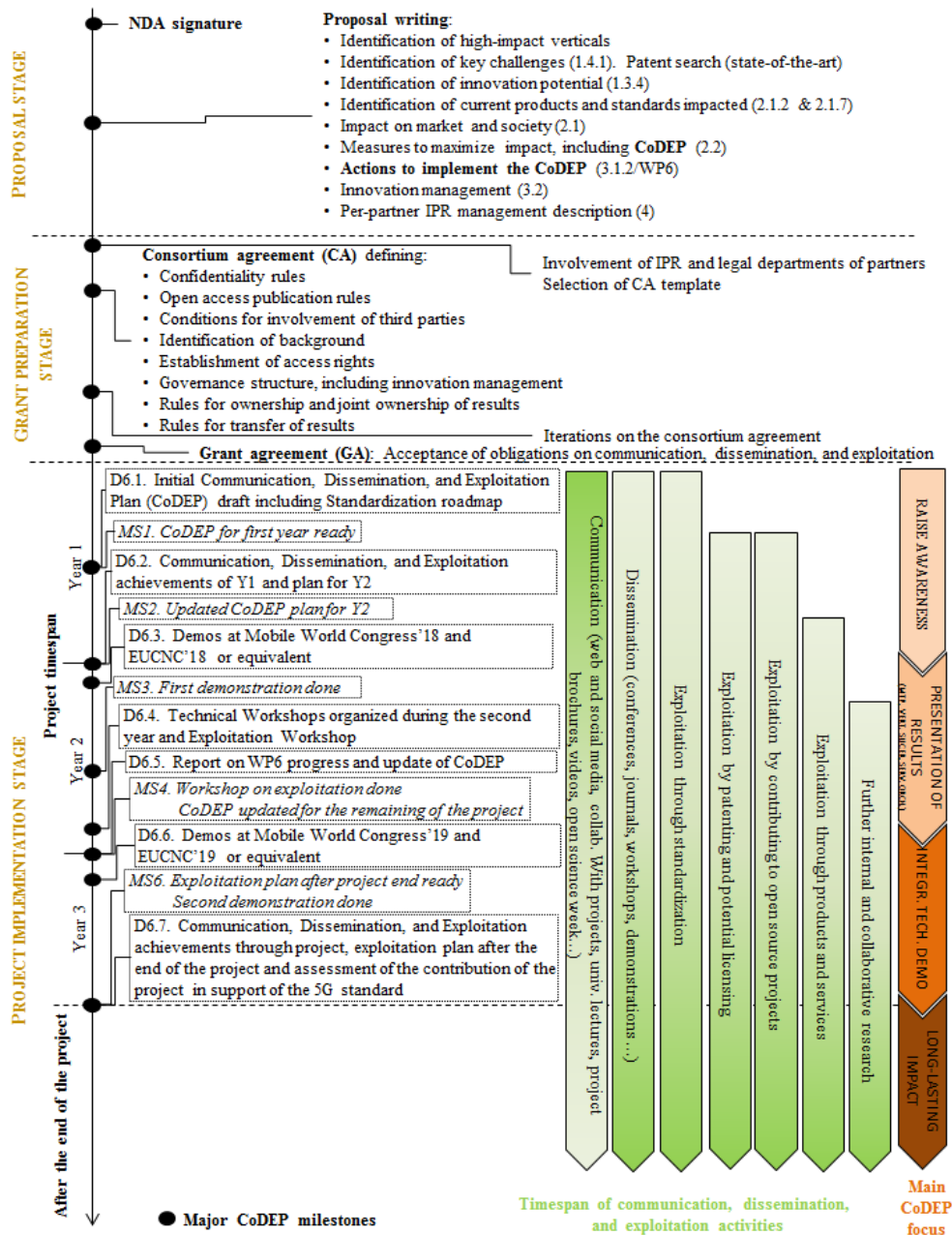

**FIGURE 22: 5G-TRANSFORMER COMMUNICATION, DISSEMINATION, AND EXPLOITATION PLAN (CODEP)**

As mentioned above, the following subsection focuses on communication activities since dissemination and exploitation ones have their own one.

**4.2.6.1 Communication activities**

This section reports on the communication activities undertaken related to the society at large and the events fostering interaction with other projects. Each subsection describes different activities and events for the promotion of the 5G-TRANSFORMER project. All 5G-TRANSFORMER partners promote the 5G-TRANSFORMER project to the general public at large, and many activities (e.g., social media and video post, press releases and news release, communication articles published, etc.) were carried out, as seen in the following subsections.

#### 4.2.6.1.1 Web, social media, and project communication material

Following the project kick-off on June 1, 2017 in Stockholm, activities have been undertaken towards fulfilling the objectives set above. Additionally, the official project press release was released in Madrid, Spain in June 2017. Additionally, partners also released their own internal (company-wide) and external press releases as listed in Section 4.2.6.1.4. More details can also be found in the project website (<http://5g-transformer.eu/>).

The social media accounts of 5G-TRANSFORMER were also set up, and are the following:

- Twitter: [https://twitter.com/5g\\_transformer](https://twitter.com/5g_transformer)
- LinkedIn: <http://linkedin.com/in/5g-transformer-eu-project-a05311144>
- Instagram: [https://www.instagram.com/5g\\_transformer/](https://www.instagram.com/5g_transformer/)
- YouTube: [https://www.youtube.com/channel/UCIQXD0lCxTK9eh\\_mQzMweww](https://www.youtube.com/channel/UCIQXD0lCxTK9eh_mQzMweww)

By looking at the metrics, one can conclude that there has been a steady increase of the impact of the website and of social media, which is a relevant outcome as part of the CoDEP execution during the *raise awareness* phase of the project. More specifically, for the website, we have observed around 4000 visits and 1800 visitors in the last quarters with the most visited page reaching more than 1000 visits (/publications). As for Twitter, the number of followers reached 275. The number of impressions (i.e., times a user is served a Tweet in timeline or search results) moved from thousands during the initial months of the project to 10s of thousands in recent quarters (up to a max. of almost 33000). The same trend as in Twitter is observed in the rest of social media (Instagram, LinkedIn and YouTube), though with a lower intensity. For instance, in Instagram, as of April 2018, the project has 19 followers and 172 LinkedIn followers. Furthermore, the 5G-TRANSFORMER high-level video had more than 500 visualizations since February 2018 (in addition to those during the events in which it was played, such a Mobile World Congress). More technical videos will be recorded and published on the YouTube channel for some of the demonstrations of the project (e.g., EUCNC).

#### 4.2.6.1.2 Communication leaflets and poster

Various communication leaflets and posters were produced. They were used in various events and available on the web for the promotion of the 5G-TRANSFORMER project. A specific version was generated to be used in the 5G-Infrastructure Association booth and booths from partners during Mobile World Congress 2018. Figure 23 presents an example of leaflet prepared for Mobile World Congress 2018.





## 5G-Transformer: 5G Mobile Transport Platform for Verticals

### 5G TRANSFORMER

**PROJECT COORDINATOR**  
 Arturo Azcorra  
 UNIVERSIDAD CARLOS III DE MADRID (UC3M)

**TECHNICAL MANAGER**  
 Xavier Costa  
 NEC LABS EUROPE (NEC)

**PARTNERS**

**START DATE:** 01/06/2017  
**END DATE:** 30/11/2019  
**COST:** 7.985.582,41€

**MORE INFORMATION**  
[www.5g-ppp.eu/5G-Transformer](http://www.5g-ppp.eu/5G-Transformer)

**CONTACT**  
[5G-Transformer-Contact@5g-ppp.eu](mailto:5G-Transformer-Contact@5g-ppp.eu)

### MAIN OBJECTIVES

5G-Transformer aims to transform today's rigid mobile transport networks into an SDN/NFV-based Mobile Transport and Computing Platform (MTP), which brings the "Network Slicing" paradigm into mobile transport networks by provisioning and managing MTP slices tailored to the specific needs of vertical industries. The technical approach is twofold:

- (1) Enable vertical industries to meet their service requirements within customised MTP slices; and
- (2) Aggregate and federate transport networking and computing fabric, from the edge all the way to the core and cloud, to create and manage MTP slices throughout a federated virtualized infrastructure.

The goal of 5G-Transformer is to design, implement and demonstrate a 5G platform that addresses the aforementioned challenges.

### USE CASES

The project will demonstrate several vertical industry use cases:



### CHALLENGES

5G-Transformer defines three novel building blocks that will be developed and demonstrated integrating the aforementioned vertical industries:

- (1) Vertical Slicer as the logical entry point (i.e., one stop shop) for verticals to request the creation of their respective transport slices in a short time-scale (in the order of minutes).
- (2) Service Orchestrator for end-to-end service orchestration and federation of transport networking and computing resources from multiple MTP domains and for management of their allocation to slices.
- (3) Mobile Transport and Computing Platform as the underlying unified transport stratum for integrated fronthaul and backhaul networks, hence building on the foundations of 5GPPP Phase 1 projects.



[https://twitter.com/5g\\_transformer/](https://twitter.com/5g_transformer/)



[https://www.instagram.com/5g\\_transformer/](https://www.instagram.com/5g_transformer/)

<https://goo.gl/uB5TIL>



<https://www.linkedin.com/in/5g-transformer-eu-project-a05311144/>

FIGURE 23: MOBILE WORLD CONGRESS 2018 5G-TRANSFORMER LEAFLET

#### 4.2.6.1.3 Communication videos

The 5G-TRANSFORMER general video was published on the 19 February, 2018. This video introduces the use cases considered in the 5G-TRANSFORMER project: eHealth, Automotive, M(V)NO, Media, Cloud robotics. It also explains how 5G-TRANSFORMER can enable vertical industries to meet their service requirements within customized 5GT-MTP slices and how it can also enable the federation among transport networking and computing fabric from the edge up to core and cloud belonging to different domains.

Also, this video was shown in Mobile World Congress in Barcelona, Spain, 2018 in the 5G-Infrastructure Association booth as well as in the booth of partners.

Additionally, this video was registered to participate in the “Showcase your project!” initiative (<http://ec.europa.eu/research/investeuresearch/index.cfm>), which builds a library of videos explaining how European research impacts the daily lives of citizen. It is available at: <https://www.youtube.com/playlist?list=PLvpwljZTs-LjHDvRTqlyjfLeflXDak5er>

An interview to Prof. Arturo Azcorra, deputy coordinator of 5G-TRANSFORMER, recorded at EuCNC 2018 has also been published.

#### 4.2.6.1.3.1 Demo videos

As part of the technology demonstrations efforts, videos are expected to be recorded throughout the project lifetime and made available through our website. These videos will present the goals and scenario of the demo and explain in detail all the steps followed. They also show the final result after the 5G-TRANSFORMER service is deployed.

As of the time of writing, videos of the EuCNC 2018 demonstrations (see Table 2) were recorded and have been uploaded to the video gallery of the 5G-TRANSFORMER website (<http://5g-transformer.eu/index.php/dissemination/video-gallery/>).

#### 4.2.6.1.4 Press releases and news

A list of the press releases on 5G-TRANSFORMER project that appear in 5G-TRANSFORMER website. Two official project-wide press releases were published, for the kick-off and for Mobile World Congress 2018:

- <http://5g-transformer.eu/index.php/2017/06/20/5g-transformer-press-release/>
- <http://5g-transformer.eu/index.php/2018/02/23/the-5g-transformer-project-presents-the-future-5g-mobile-transport-platform-for-verticals-at-mwc18/>

Furthermore, the project regularly publishes news on relevant events and results. For instance, one was published on the participation to the Common Dissemination Booster and two on the presence at EUCNC 2018, among others:

- <http://5g-transformer.eu/index.php/2018/06/21/5g-transformer-presence-at-eucnc-2018-ljubljana-slovenia/>
- <http://5g-transformer.eu/index.php/2018/06/22/the-european-commission-representatives-visited-the-5g-coral-5g-transformer-and-5g-ex-joint-booth-at-eucnc-2018/>
- [http://5g-transformer.eu/index.php/2018/06/05/5g\\_in\\_cbd/](http://5g-transformer.eu/index.php/2018/06/05/5g_in_cbd/)

Additionally, several press releases were also issued by various partners at various stages of the project, which were promoted through their respective communication channels (including their website):

- <https://www.mirantis.com/blog/network-slicing-and-5g-and-wireless-oh-my/>
- <http://www.cttc.cat/european-industrial-and-academic-partners-join-to-develop-a-5g-mobile-transport-platform-for-verticals/>
- <https://www.ericsson.com/research-blog/5g-transformer-eu-project-underway/>
- <https://www.networks.imdea.org/whats-new/news/2018/investigadores-uc3m-presentan-sus-novedades-sobre-5g-mobile-world-congress-2018>

- <http://www.cttc.cat/cttc-contributes-to-the-future-5g-mobile-transport-platform-for-verticals-at-mwc18/>
- <http://5g-xcast.eu/2018/04/26/prof-narcis-cardona-presentation-at-the-5g-forum-in-malaga/>
- <http://www.madrid.es/portales/munimadrid/es/Inicio/Emergencias-y-seguridad/SAMUR-Proteccion-Civil/?vgnnextfmt=default&vgnextoid=c88fcd31d3b28fe410VgnVCM100000d90ca8c0RCRD&vgnnextchannel=f9cd31d3b28fe410VgnVCM1000000b205a0aRCRD&idCapitulo=6149819>
- [http://s3platform.jrc.ec.europa.eu/digital-innovation-hubs-tool?p\\_p\\_id=%20digitalinnovationhub\\_WAR\\_digitalinnovationhubportlet&p\\_p\\_lifecycle=0&p\\_p\\_state=normal&p\\_p\\_mode=view&p\\_p\\_col\\_id=column-%201&p\\_p\\_col\\_count=1&formDate=1524592222123&freeSearch=5tonic&evolutionStages=3](http://s3platform.jrc.ec.europa.eu/digital-innovation-hubs-tool?p_p_id=%20digitalinnovationhub_WAR_digitalinnovationhubportlet&p_p_lifecycle=0&p_p_state=normal&p_p_mode=view&p_p_col_id=column-%201&p_p_col_count=1&formDate=1524592222123&freeSearch=5tonic&evolutionStages=3)
- <http://5g-transformer.eu/index.php/2018/04/20/5g-transformer-in-collaboration-with-samur-proteccion-civil/>

But most notably, the project also had some presence in relevant technical communication media, such as sdxcentral or globenewswire:

- <http://www.globenewswire.com/news-release/2017/06/21/1027019/0/en/European-Industrial-and-Academic-Partners-Join-to-Develop-a-5G-Mobile-Transport-Platform-for-Verticals.html>
- <https://www.sdxcentral.com/articles/news/new-european-5g-group-will-focus-on-network-slicing-industry-verticals/2017/06/>
- <https://www.sdxcentral.com.cdn.ampproject.org/c/s/www.sdxcentral.com/%20articles/news/trials-use-cases-top-5g-developments-2017/2017/12/amp/%20Network%20Slicing%20Gets%20Traction>

The channels available through the 5G-PPP COMMS group, coordinated by the To-Euro-5G CSA were also exploited throughout the first year of the project. This is a group established at the 5G-PPP projects level to raise awareness of the activities of these projects among them and also outside, through various media (e.g., newsflash, social media, periodic audioconferences). For instance:

- <https://5g-ppp.eu/european-industrial-and-academic-partners-join-to-develop-a-5g-mobile-transport-platform-for-verticals/>
- <https://5g-ppp.eu/newsflash-october-2017/>
- <https://5g-ppp.eu/the-5g-transformer-project-presents-the-future-5g-mobile-transport-platform-for-verticals-mwc18/>

#### 4.2.6.1.5 Communication articles

In addition to publishing technical papers, the project also promotes the project scope and vision at a higher-level. Table 12 lists the communication articles published to introduce the 5G-TRANSFORMER project from the point of views of a mobile network operator and verticals.

TABLE 12: COMMUNICATION ARTICLES

	Title	Venue
1	A Network Service Provider Perspective on Network Slicing	IEEE Softwarization, January 2018
2	5G-TRANSFORMER (5G Mobile Transport Platform for Verticals) (sent)	5G Annual Journal Third Edition

#### 4.2.6.1.6 Communication presentation/lectures

Table 13 lists the presentations and talks targeting a wide general audience. This includes high-school students or society at large. It also includes lectures given to undergraduate and graduate students, as part of this general, but a bit more technical audience. And finally, it also includes general talks given at more technical for a but not necessarily specifically working on the same topics as 5G-TRANSFORMER (e.g., 5G Summit) as part of the interaction with other projects. They all describe the project general ideas and scope without entering too much into technical details.

TABLE 13: COMMUNICATION PRESENTATION AND LECTURES

	Activity
1	Talk entitled “5G Networks to realize Network society“ at the “5G technology for automotive domain” workshop, 2017, including the 5G-TRANSFORMER approach.
2	A talk on 5G in general, and more specifically, on 5G-TRANSFORMER was given to high-school students and general public in the context of 22nd Open Science Week (Setmana de le Ciència) in November 2017. It is organized by the Catalan Research and Innovation Foundation (FCRi). Information available at: <a href="http://www.cttc.cat/the-cttc-will-participate-in-the-22nd-edition-of-the-science-week-2017/">http://www.cttc.cat/the-cttc-will-participate-in-the-22nd-edition-of-the-science-week-2017/</a>
3	Organization of the Internet Festival ( <a href="http://www.internetfestival.it/">http://www.internetfestival.it/</a> ), the Robotics Festival 2017 ( <a href="http://www.festivalinternazionaledeellarobotica.it/en/">http://www.festivalinternazionaledeellarobotica.it/en/</a> )
4	Three-hour course taught at the National Chiao Tung University (NCTU) in Taiwan on topics related with 5G-TRANSFORMER
5	Master courses in UC3M on NFV and SDN for 5G networks
6	SSSA presents 5G-TRANSFORMER in 5G Summit in Trento
7	5G-TRANSFORMER presentation: 5G Mobile Transport Platform for Verticals in EuCNC workshop in 2017
8	POLITO presents 5G-TRANSFORMER in IEEE 5G Summit 2017 talk
9	SAMUR participation and presentation in 5G Forum in Malaga

#### 4.2.6.1.7 Collaboration with other projects

A series of activities have been carried out together with 5G-PPP projects in the framework of the various working groups. Table 14 lists the main activities within the 5G PPP CSA Working Groups (WGs). A variety of other activities, like joint organization of events or special sessions, joint booth applications at events, or joint writing of papers were carried out. They will be explained in the corresponding sections below. This section focuses on the 5G-PPP working group activities.

TABLE 14: ACTIVITY WITHIN 5G PPP CSA WGS

	Activity with 5G PPP WGs
1	Presentation to EC H2020 5G Infrastructure PPP Technical board on Performance KPIs and 5G-TRANSFORMER status in this respect. Active participation on this activity (periodic calls).
2	Inputs on 3GPP and 5G-TRANSFORMER to 5G-PPP Pre-Standardization

	Working Group (WG). Various conference calls, including one with the WG Chair on including other non-3GPP activities.
3	Input on 5G-TRANSFORMER for preparation of a brochure for EUCNC. 5G PPP Network Management & QoS WG
4	Participation to 5G PPP Trials WG and the roadmap (5G Pan-European trials roadmap 3.0.) generated by the group ( <a href="https://5g-ppp.eu/5g-trials-roadmap/">https://5g-ppp.eu/5g-trials-roadmap/</a> ).
5	Participation to 5G PPP Architecture WG. The group organized a session at EuCNC 2018.
6	Active participation to the 5G PPP Software Networks WG. The 5G-TRANSFORMER project was presented in September 2017. 5G-TRANSFORMER contributed actively to the white paper 'From Webscale to Telco, the Cloud Native Journey'. The white paper will be presented at a EUCNC 2018 workshop, to which 5G-TRANSFORMER participates as well.

#### 4.2.6.2 Deviations

During this first reporting period, the project achieved all its milestones in due time and progress was as expected. So, no deviations had to be handled.

#### 4.2.6.3 Corrective actions

No corrective actions needed.

#### 4.2.7 WP7

The management of the project, dedicated WP in the DoA, is led by UC3M.

The main activities in this period are related to ensure that the project runs successfully, that the partners successfully and efficiently collaborate and that the technical objectives are achieved taking care of the time and the costs of the project. The project coordinator (PC) administered the financial contribution, allocating it between the beneficiaries, and activities in accordance to the Grant Agreement. The payments have been done with no delay. The PC kept the records and financial accounting, and informed the European Commission of the distribution of the EU financial contribution. The PC verified consistency between the reports and the project tasks and monitors the compliance of beneficiaries with their obligations.

In M1 the Deliverable D7.1 (Project Handbook), was delivered on time. It includes the management procedures for the proper development and implementation of the project.

During this reporting period an amendment has been carried out. The main changes implemented in this amendment are listed below:

- Included NECLE as new beneficiary due to a partial takeover, replacing NECLE for NECLE in Work Packages, Deliverables and Milestones.
- Change in WP1 and WP5 Leaders; and change in Innovation Manager.
- Updated the Project Logo.

##### 4.2.7.1 Task 7.1: Project administrative, financial, and legal management

In this period (M1-M13) four plenary meeting were held: the Kick-off Meeting and three progress meetings:

- Kick-off Meeting on June 1-2, 2017 in Stockholm (hosted by TEI). This meeting focused on the general aspects of the project, the main objectives and the main activities of each partner. The first activities are related to the definition of the vertical uses cases and the identification of the associated requirements.

- 2nd plenary meeting on September 20-22, 2017 in Madrid (hosted by UC3M). The meeting focused on the refinement of the use cases and requirements, as well as an initial discussion on the initial architecture of the project.
- 3rd plenary meeting on January 16-18, 2018 in Rennes (hosted by BCOM). The main topics discussed during the meeting were overall architecture refinement and internal 5GT-MTP, 5GT-SO and 5GT-VS architectures. Planning of D2.1, D3.1 and D4.1 was also discussed.
- 4th plenary meeting on April 9-11, 2018 in Pisa (hosted by NXW, TEI and SSSA). The meeting focused on WP1, WP2, WP3, WP4, WP5 and WP6 progress and planning of activities and next deliverables.

Initially, weekly technical remote meetings (per WP) were held to allow synchronization between the different partners using a collaborative tool for audioconferences (gotomeeting). As the project made more progress, some of these meetings have changed to bi-weekly frequency. A shared calendar is used to reflect and share the planned remote meetings to keep the partners informed about the date and hour.

A report of the project progress in terms of technical activities and resources allocation is planned each three months by means of the Quarterly Management Reports. A final report is planned for the end of the project (M30).

The Consortium used the following tools for the management of the project:

- Redmine: a web based tool for the description of the activities and the coordination between the partners. A dedicated section has been created as repository of the meeting minutes. This includes a shared calendar for meetings bookkeeping.
- SVN repository: the repository where documentation and software have been stored and shared among the partners.
- Several mailing lists have been created in order to communicate with the partners: 5g-transformer-all, 5g-transformer-wp1, 5g-transformer-wp2, 5g-transformer-wp3, 5g-transformer-wp4, 5g-transformer-wp5, 5g-transformer-wp6, 5g-transformer-wp7, 5g-transformer-pmt, 5g-transformer-admin and 5g-transformer-contact.

The 5G-TRANSFORMER website is available from the beginning of the project (<http://5g-transformer.eu>). Moreover, Twitter ([https://twitter.com/5g\\_transformer](https://twitter.com/5g_transformer)), Instagram ([https://www.instagram.com/5g\\_transformer/](https://www.instagram.com/5g_transformer/)), LinkedIn (<http://linkedin.com/in/5g-transformer-eu-project-a05311144>) accounts and a YouTube channel ([https://www.youtube.com/channel/UCIQXD0ICxTK9eh\\_mQzMweww](https://www.youtube.com/channel/UCIQXD0ICxTK9eh_mQzMweww)) have been created.

#### 4.2.7.2 Task 7.2: Technical coordination, Innovation and Quality management

This task is led by NECLE as technical manager and UC3M and TEI participate as project coordinator and innovation manager, respectively. NECLE as the project technical manager, leads the technical innovations for the project and coordinating the work of all WPs. UC3M as project coordinator ensures the project progresses towards its objectives. TEI as the innovation manager has monitored the innovation and exploitation activities.

#### 4.2.7.3 Task 7.3: Technical coordination, Innovation and Quality management

Within 5G PPP, the project participates in the cross-project work groups (WGs), where the work of multiple projects can converge into identifying the shared issues and developing supported program level position on technical and strategic items. 5G-TRANSFORMER actively participates in seven working groups. Table 15 only lists the main representatives of the project. Other partners may participate as well.

**TABLE 15: 5G-TRANSFORMER AND 5G PPP CSA WGS**

5G PPP CSA WG	Description of the activities	5G-T representative
<b>Pre-Standardization WG</b>	Attendance to periodic conference calls, including one with the WG Chair on including other non-3GPP activities. Reporting of 3GPP activities and 5G-TRANSFORMER.	IDCC
<b>5G Architecture WG</b>	Attendance to periodic conference calls, including one where 5G-TRANSFORMER architecture was presented. Participation to 5G PPP Architecture WG. The group organized a session at EuCNC 2018, where 4 representatives of the project participated representing different stakeholders/views: Operators, Verticals, Vendors and the project as a whole.	NECLE
<b>Software Networks WG</b>	Active participation to the 5G PPP Software Networks WG. The 5G-TRANSFORMER project was presented in September 2017. 5G-TRANSFORMER contributed actively to the white paper ‘From Webscale to Telco, the Cloud Native Journey’. The white paper will be presented at a EUCNC 2018 workshop, to which 5G-TRANSFORMER participates as well.	NOK-N, UC3M
<b>Vision and Societal Challenges WG</b>	Attendance to periodic conference calls.	TEI
<b>Trials WG</b>	Participation to 5G PPP Trials WG and the roadmap (5G Pan-European trials roadmap 3.0.) generated by the group ( <a href="https://5g-ppp.eu/5g-trials-roadmap/">https://5g-ppp.eu/5g-trials-roadmap/</a> ).	UC3M
<b>Network Management &amp; QoS WG</b>	Attendance to periodic conference calls. Input on 5G-TRANSFORMER for preparation of a brochure for EUCNC. 5G PPP Network Management & QoS WG	POLITO
<b>Automotive WG</b>	Attendance to periodic conference calls	CRF

Additionally, ATOS and ORANGE participate in the EC H2020 5G Infrastructure PPP Technical board on Performance KPIs.

Last, but not least, NECLE and UC3M attends the Technical Board and Steering Boards.

#### 4.2.7.4 Deviations

Overall, the work package is proceeding as planned.

#### 4.2.7.5 Corrective actions

No corrective actions needed.

### 4.3 Deliverables

<b>Deliverable Progress</b>			
	On Schedule	Delayed	Completed
D1.1			X
D1.2			X
D1.3	X		
D1.4	X		
D2.1			X
D2.2	X		
D2.3	X		
D2.4	X		
D3.1			X
D3.2	X		
D3.3	X		
D3.4	X		
D4.1			X
D4.2	X		
D4.3	X		
D4.4	X		
D5.1			X
D5.2	X		
D5.3	X		
D5.4	X		
D5.5	X		
D6.1			X
D6.2			X
D6.3			X
D6.4	X		
D6.5	X		
D6.6	X		
D6.7	X		
D7.1			X
D7.2			X
D7.3			X
D7.4	X		
D7.5	X		



## 4.4 Milestones

Milestones Progress			
	On Schedule	Delayed	Completed
MS1			X
MS2			X
MS3			X
MS4			X
MS5			X
MS6			X
MS7			X
MS8	X		
MS9	X		
MS10	X		
MS11	X		
MS12	X		
MS13	X		
MS14	X		
MS15	X		
MS16	X		
MS17	X		
MS18	X		

## 4.5 Exploitable Results

### 4.5.1 Exploitation on commercial products and PoC developed internally to the companies

An exploitation strategy has been outlined to maximize the impact of the project results on products and solutions of the verticals and manufacturer partners participating in the project.

This preliminary identification activity has been reported in the Initial CoDEP D6.1 where said products and services have been grouped following the three main architectural building blocks envisioned by the project: Vertical Slicer, Service Orchestrator, and Mobile Transport and Computing Platform. Such categorization will facilitate conceptually reporting how results and outcomes achieved in the three building blocks, and in the relevant WPs, will be exploited. In this direction, there will be a continuous monitoring task to identify the key technology innovations and to evaluate how they may impact the products and services developed by the partners.

In view of the high importance given by the project to the exploitation activities, the project has appointed an Innovation Manager (Dr. Giulio Bottari from Ericsson) to lead the work and ensure successful exploitation of the innovations from the project.

Table 16 reports an initial mapping between the project main building blocks and the target PoCs, products, services, and solutions, indicated by the project partners.

**TABLE 16: MAPPING BETWEEN BUILDING BLOCKS OF THE PROJECT THE RELEVANT PARTNERS' PoCs, PRODUCTS, SERVICES AND SOLUTIONS**

Block	PoC/Product/Service/Solution	Partner
<b>Vertical Slicer</b>	Smart Platform	ATOS
	Cloud Infrastructure	ATOS
	FCA car models	CRF
	Chordant Platform	IDCC
	Converged Unifier Gateway	BCOM
	Symphony	NXW
	Sealux	NXW
	NFV Mano Solution	NXW
	Smart T-Shirt	SAMUR
<b>Service Orchestrator</b>	Backhaul Resource Manager (BRM)	NECLE
	WizHaul	NECLE
	Mirantis Cloud Platform (MCP)	Mirantis
	Cloudify	Mirantis
<b>Mobile Transport and Computing Platform</b>	5G BTSs	NOK-N
	Airframe	NOK-N
	Airframe data center	NOK-N
	NFV-based packet core	NOK-N
	MEC Platform	NOK-N
	NEC Control Platform	NECLE
	NEC iPASOLINK	NECLE
	Fronthaul 6020/6080	Ericsson
	Cloud and NFV Infrastructure	Ericsson
EdgeHaul	IDCC	

In addition to bringing project outcomes in specific commercial products, the demos and test-beds planned in the context of WP5 are expected to activate a fruitful ecosystem for experimentation where verticals, manufacturers, SMEs, operators, and academia can share requirements, constraints, feasibility of specific features and functionalities.

#### 4.5.2 Exploitation on the realization of common platform among the 5G-TRANSFORMER partners by means of testbed and demos

In Table 17 we report the plan for demo and testbed integration to show the key outputs of the 1<sup>st</sup> year of the project. We refer to section 4.2.5 for further details about the Proof of Concepts and the planning.

**TABLE 17: PLAN FOR DEMONSTRATION AND TESTBED**

Vertical Industry	Testbeds	Partners	Description	Y1 Functions (Table 10)
<b>Automotive</b>	CTTC, ARNO	CRF, CTTC, NXW, POLITICO	Message exchange with the vehicle (CAM, DeNM) with an RSU deployed on a MEC host. Video streaming service delivered to the vehicle UE.	
<b>Entertainment</b>	EURECOM, 5Tonic	ATOS	UHD video streaming service delivered to the UE using MEC resources.	FR3
<b>E-Health</b>	5Tonic,	UC3M,	Communication between an	FR3

	CTTC	SAMUR	eServer and a wearable. Logic on the eServer to generate alarms based on the information received.	
<b>E-Industry</b>	5Tonic	TEI	Network service with tight SLA requirements and using resources in private and public clouds.	FR8
<b>MNO/MVNO</b>	5Tonic, CTTC, EURECOM	BCOM, TID, ORANGE, ITRI	Network slice provisioned with tight SLA requirements.	FR8

#### 4.5.3 Exploitation on standards

5G TRANSFORMER thrust into standardization bodies is significant with a considerable amount of contributions bringing 5G TRANSFORMER technology into key SDOs forums such as ETSI MEC, IETF and 3GPP.

As shown in Table 18, 5G TRANSFORMER is quickly approaching to meeting its goals as the project has been able to bring a significant number of contributions to key SDOs out of which 6 of them have been adopted or agreed. The following table summarized the current status of the standardization effort in 5G TRANSFORMER.

**TABLE 18: 5G-TRANSFORMER CONTRIBUTIONS TO STANDARDS**

Target SDOs	Standards Contribution into Key SDO or foundation enabler	Status	Date
ETSI MEC	Creation of WI ETSI MEC by 5G-TRANSFORMER	Agreed	21/11/2017
NGMN	NGMN abstraction based on 5G-TRANSFORMER E2E Architecture diagram		25/07/2017
SAC	Creation of Standardization Activities Roadmap (SAR) within the 5G-TRANSFORMER project	Done	09/04/2018
ETSI MEC(24)	<ol style="list-style-type: none"> <li>1. Instantiating a Network Slice integrating MEC applications, using 3GPP elements.</li> <li>2. Use case on creation and termination of a slice</li> <li>3. MEC reference architecture in a NFV environment</li> <li>4. Managing Traffic Redirection from the Mobile Edge Platform: Approaches to Address Issue#9 of ETSI MEC017</li> </ol>	Accepted	07/05/2018
MEC	MEC meeting presentation by IDCC, requirements for MEC Systems with 3 <sup>rd</sup> Parties		10/05/2018
IETF (DMM WG)	Proxy Mobile IPv6 extensions for Distributed Mobility Management ( <a href="https://tools.ietf.org/html/draft-bernardos-dmm-pmipv6-dlif-01">https://tools.ietf.org/html/draft-bernardos-dmm-pmipv6-dlif-01</a> )	Adopted	02/03/2018
IRTF (NFVRG)	Network Virtualization Research Challenges ( <a href="https://datatracker.ietf.org/doc/draft-irtf-nfvrg-gaps-network-virtualization/">https://datatracker.ietf.org/doc/draft-irtf-nfvrg-gaps-network-virtualization/</a> ) draft-irtf-nfvrg-gaps-network-virtualization	Adopted	03/07/2017 (+ updates)

IETF (NFVRG)	Multi-domain Network Virtualization ( <a href="https://datatracker.ietf.org/doc/draft-bernardos-nfvrg-multidomain/">https://datatracker.ietf.org/doc/draft-bernardos-nfvrg-multidomain/</a> ) draft-bernardos-nfvrg-multidomain		05/03/2018 (+ updates)
IETF (SFC WG)	Service Function discovery in fog environment ( <a href="https://datatracker.ietf.org/doc/draft-bernardos-sfc-discovery/">https://datatracker.ietf.org/doc/draft-bernardos-sfc-discovery/</a> ) draft-bernardos-sfc-discovery		05/03/2018
IRTF (NFVRG)	IPv6-based discovery and association of Virtualization Infrastructure Manager (VIM) and Network Function Virtualization Orchestrator (NFVO) ( <a href="https://datatracker.ietf.org/doc/draft-bernardos-nfvrg-vim-discovery/">https://datatracker.ietf.org/doc/draft-bernardos-nfvrg-vim-discovery/</a> ) draft-bernardos-nfvrg-vim-discovery		05/03/2018
IETF (COMS BoF)	COMS Architecture ( <a href="https://datatracker.ietf.org/doc/draft-geng-coms-architecture/">https://datatracker.ietf.org/doc/draft-geng-coms-architecture/</a> ) draft-geng-coms-architecture		05/03/2018
IETF (COMS BoF)	Problem Statement of Common Operation and Management of Network Slicing ( <a href="https://datatracker.ietf.org/doc/draft-geng-coms-problem-statement/">https://datatracker.ietf.org/doc/draft-geng-coms-problem-statement/</a> ) draft-geng-coms-problem-statement		05/03/2018
IETF (CCAMP WG)	A YANG Data Model for Microwave Topology ( <a href="https://datatracker.ietf.org/doc/draft-ye-ccamp-mw-topo-yang/">https://datatracker.ietf.org/doc/draft-ye-ccamp-mw-topo-yang/</a> ) draft-ye-ccamp-mw-topo-yang		05/03/2018
IETF (CCAMP WG)	A framework for management and control of microwave and millimeter wave interface parameters ( <a href="https://datatracker.ietf.org/doc/draft-ietf-ccamp-microwave-framework/">https://datatracker.ietf.org/doc/draft-ietf-ccamp-microwave-framework/</a> ) draft-ietf-ccamp-microwave-framework	Adopted	05/01/2018
IETF (CCAMP WG)	A YANG Data Model for Microwave Radio Link ( <a href="https://datatracker.ietf.org/doc/draft-ietf-ccamp-mw-yang/">https://datatracker.ietf.org/doc/draft-ietf-ccamp-mw-yang/</a> ) draft-ietf-ccamp-mw-yang		03/03/2018
3GPP SA2	(S2-183925-S2-183923) New Key Issue: Identify scenarios when Network Slices cannot coexist within a single PLMN	Agreed	16/04/2018

## 4.6 Impact

5G-TRANSFORMER targets ICT-07-2017: 5G PPP Research and Validation of critical technologies and systems which challenge is to eliminate the limitations of network infrastructures, by making them capable of supporting a wider array of requirements, with respect to the current situation, and with the capability of flexibly adapting to different "vertical" application requirements. This challenge includes optimisation of cost functions and of scarce resources (e.g. energy, spectrum), as well as migration towards new network architectures.

Section 2.1 of the DoA has indicated how the project will contribute to the specific challenge of the topic ICT-07-2017 with seven impact criteria. In the following it is

reported how results obtained in the first year of the project are progressing towards the said expected impacts.

**Expected Impact 1: Overarching impact: 40% of the world communication infrastructure market for EU headquartered companies (all strands).**

The technologies developed in 5G-TRANSFORMER are expected to strengthen the position of EU companies in the upcoming 5G Mobile Network market, both in Europe and worldwide, for the whole value chain: the architecture and the relevant building blocks of 5G-TRANSFORMER are broad enough so that basically all actors of the ICT domain are involved in its key innovations: Verticals, Operators/Service Providers, Manufacturers, and SMEs.

In the first year of the project, Vertical industries partners (i.e. CRF, ATOS and SAMUR) have provided a clear picture of all the needs that are specific of their sector of interest, identifying the key innovation areas that need to be advanced, and the relevant use-cases demanding very different requirements. D1.1 [1] reports said use cases and relevant requirements also outlining the key project performance indicators and how they relate to the ones identified by 5G-PPP.

As described in Section 1.2 of the current report, the first year of project activity led to the following relevant outputs:

- Definition of use cases and scenarios to be used to challenge the system architecture.
- Design of the baseline architecture, aligned with the SDOs relevant in the area.
- Initial design of the 5GT-MTP architecture.
- Initial design of the 5GT-VS architecture.
- Initial design of the 5GT-SO architecture.
- Design and setup of the interconnection of the different test sites.
- First integration plan towards the implementation of several proofs of concept around the vertical use cases considered in the project.

Such results have been achieved thanks to the continuous interworking of the 5G-TRANSFORMER partners that includes:

- Two leading Mobile Network Operators (MNOs), namely Orange and Telefonica, have business interests in 11 countries in Europe (e.g., France, UK, Germany, Spain, Poland, etc.), plus more than other 30 countries across different geographical areas (mainly in Africa and America), accounting for about 22% of the EU market share (84M Orange, 84M Telefonica).
- Four manufacturers: Ericsson, Nokia, NEC, and Interdigital. They represent leading providers of mobile network equipment and solutions for Telecom Operators in Europe and worldwide. Their product portfolios cover most aspects of Mobile Broadband (MBB) deployment, including LTE Radio Access Networks, Transport Networks, Evolved Packet Core equipment, MEC solutions, and SDN software products, acting as worldwide leaders in all those areas. These manufacturers have declared a direct impact of 5G-TRANSFORMER outcomes on their products (see Section 4.5.1).
- The SMEs add novel complementary technologies to the project such as NFV and Cloud orchestration (Mirantis), Unified Gateway (BCOM), SDN control (Nextworks). The project has recognised the importance of SMEs in the economic development of Europe, hence allocating 20.9% of its budget to SMEs.

**Expected Impact 2: Novel business models through innovative sharing of network resources across multiple actors (all strands).**

By reducing the entry barrier through virtualization and standardized interfaces based on open APIs or protocols, 5G-TRANSFORMER accelerates the integration of new services over existing and new networks, creating a new business model which includes Mobile Network Operators (MNO), Mobile Virtual Network Operators (MVNO), Over The Top (OTT) service providers, and providers of vertical services in different, heterogeneous, sectors.

5G-TRANSFORMER have defined a novel architecture which provides, through the Vertical Slicer (5GT-VS) block, all these actors with high-level APIs for the creation of network slices that integrate network and computing resources belonging to the physical network infrastructure of one or multiple network operators. Through said APIs, the system hides unnecessary details from the verticals, allowing them to focus on the definition of the services and the required Service Level Agreements (SLAs)

Having defined a Service Orchestrator (5GT-SO) module, a network slice is handled as a service: it is created, enforced, and managed over a shared infrastructure which includes transport and computing.

In summary, the 5GT-VS eases service definition for verticals and the 5GT-SO provides a uniform view of federated infrastructures, lowering the entry barrier for new actors.

**Expected Impact 3: Definition of 5G network architecture and of core technological components (strands 1 and 3).**

5G-TRANSFORMER aims at building a novel architecture integrating transport and core networks into a common sliceable transport stratum to provide verticals with end-to-end services, relying on SDN, NFV, and MEC as core technological components.

The architecture is based on three major components, each addressed by a dedicated working package of the project: 5GT-VS, 5GT-SO and 5GT-MTP. 5GT-VS is the entry point for the vertical requesting a service and it handles the association of these services with slices as well as network slice management. 5GT-SO is responsible for end-to-end orchestration of services across multiple domains and for aggregating local and federated resources and services and exposing them to the 5GT-VS in a unified way. 5GT-MTP provides and manages the virtual and physical IT and network resources on which service components are eventually deployed. It also decides on the abstraction level offered to the 5GT-SO.

**Expected Impact 4: Proactive contribution to the 3GPP standardisation activity on 5G, and to other standardisation activities, e.g., ONF, ETSI-NFV, IEEE; proactive contribution to the WRC 19 preparation for 5G spectrum (all strands).**

The standardization framework of 5G-TRANSFORMER is wide thanks to its mixture of enabling technologies such as NFV, SDN, and MEC, which are hot areas of standardization and open source developments in various Standard Development Organizations (SDO) and forums (e.g., 3GPP, ETSI, IETF, IEEE, ONF).

With the scope to boost the contribution to SDOs, 5G-TRANSFORMER has formed a Standardization Advisory Committee (SAC) composed of standardization experts supporting 5G-TRANSFORMER in all the key relevant SDOs. These include 3GPP, IETF, ETSI MEC, and IEEE. Members and Moderator of the SAC have been appointed from expert researchers from partners of 5G TRANSFORMER with relevant and

operational involvement in each of the key SDOs, which have been identified as essential within the project. This list of experts is outlined in D6.1 [21].

A Standardization Activity Roadmap (SAR) has been produced and agreed during the 5G TRANSFORMER plenary meeting held in Rennes, France, on January 2018.

Details on the standardization activity in period one and on the SAR are reported in D6.2 [22].

**Expected Impact 5: Proof-of-concept and demonstrators beyond phase one and validating core functionalities and KPI's in the context of specific use cases with verticals closely associated to the demonstrations and validation. Indicative sectors include: automotive, connected cars; eHealth; video/TV broadcast; Energy management; very high density locations and events (strands 1 and 3).**

One of the main goals of 5G-TRANSFORMER is to validate the technology components designed and developed in the project through demonstrators and proof-of-concepts (PoC). WP5 oversees integrating all the technological components provided by WP2, WP3, and WP4 and include these components in an integrated testbed formed by four different sites, provided by partners of the project. The testbed description is illustrated in D5.1 [6], which also includes the initial planning of the PoCs and the relevant technological and functional requirements.

Using the developed testbed, the use cases selected for 5G-TRANSFORMER will be deployed and functionally validated. The goal is to validate the 5G-TRANSFORMER architecture and functions in realistic conditions and demonstrate the KPIs of each specific use case. In particular:

- eHealth use case will focus on ubiquitous coverage and service creation time (i.e., to create/extend a service in a different area)
- Video/TV broadcast and events use case will focus on data rate (i.e., 4K videos and beyond), density (i.e., number of devices), e2e latency (i.e., content delivered at the same time to different devices), reliability (i.e., maximum packet loss), and coverage.
- Automotive use case will focus on low latency and mobility (i.e., autonomous cruise control), position accuracy (i.e., centimetres), reliability and communication range (i.e., collaborative ADAS), and data rate (i.e., over-the-air updates).

Feedbacks, insights, and key learnings obtained from the testbed operation and real-world deployments of use cases will be exploited to improve the 5G-TRANSFORMER system.

**Expected Impact 6: Network function implementation through generic IT servers (target) rather than on non-programmable specific firmware (today) (strand 3).**

5G-TRANSFORMER defines a programmable architecture for heterogeneous verticals to deploy their services over a common multi-domain infrastructure using virtual slices composed by VNFs running in the cloud or MEC on generic IT servers. In terms of deployment, the project platform relies on recent virtualization techniques for VNF composition/decomposition and orchestration algorithms to place VNFs over the transport and computing infrastructure, providing business-driven network slices, i.e., a differentiated, virtually isolated view of the network.

Per-tenant RAN functions (i.e., integrated fronthaul/backhaul, flexible functional split) and core services (i.e., MME, S-GW, P-GW) will be run in cloud data centres scattered through the transport network.

The deployed 5G-TRANSFORMER entities will use Application Programming Interfaces (API) among components through which the system hides unnecessary details from the verticals, allowing them to focus on the definition of the services and the required Service Level Agreements (SLAs) and enabling services to be deployed on commodity hardware.

**Expected Impact 7: Trustworthy interoperability across multiple virtualized operational domains, networks and data centres (all strands).**

5G-TRANSFORMER envisions the creation of network slices by federating transport and computing resources from different network operators' domains. These can be operated, managed, and orchestrated using different VIM or transport technologies.

The 5G-TRANSFORMER architecture includes a common orchestration system, interoperating with the different technologies used by the network domains through well-defined interfaces, which enable service and resource federation across different administrative domains, allowing 5G-TRANSFORMER service providers to enhance their service offerings to their customers by peering with other providers. Project defined APIs allow a provider to become user of another provider's service towards a true multi-domain end-to-end service.

More details are included in D4.1 [5].

#### 4.6.1 Progress towards the 5G-PPP Key Performance Indicators

In Table 19 we detail the KPIs which are most relevant for the project as described in [1], and in Table 19 we show how these KPIs map to the ones established by the 5G-PPP [26] (notice that we only mention the 5G-PPP KPIs which are relevant for the project). We refer to section 4.2.5.3 to see progress of this in terms of implementation and demos.

**TABLE 19: 5G-TRANSFORMER KPIs**

KPI	Acronym	Description
End-to-end latency	LAT	E2E latency, or one trip time (OTT) latency, refers to the time it takes from when a data packet is sent from the transmitting end to when it is received at the receiving entity, e.g., internet server or another device.
Reliability	REL	Refers to the continuity in the time domain of correct service and is associate with a maximum latency requirement. More specifically, reliability accounts for the percentage of packets properly received within the given maximum E2E latency (OTT or RTT depending on the service).
User data rate	UDR	Minimum required bit rate for the application to function correctly.
Availability (related to coverage)	A-COV	The availability in percentage is defined as the number of places (related to a predefined area unit or pixel size) where the QoE level requested by the end-user is achieved divided by the total coverage area of a single radio cell or multi-cell area (equal to the total number of



		pixels) times 100.
Mobility	MOB	No: static users Low: pedestrians (0-3 km/h) Medium: slow moving vehicles (3-50 km/h) High: fast moving vehicles, e.g. cars and trains (>50 km/h)
Device density	DEN	Maximum number of devices per unit area under which the specified reliability should be achieved.
Positioning accuracy	POS	Maximum positioning error tolerated by the application, where a high positioning accuracy means a little error.
Confidentiality	CON	Preserving authorized restrictions on information access and disclosure, including means for protecting personal privacy and proprietary information.
Integrity	INT	Guarding against improper information modification or destruction, and includes ensuring information non-repudiation and authenticity.
Availability (related to resilience)	A-RES	Ensuring timely and reliable access to and use of information.
Traffic type	TRA	Depending on to the amount of data moving across a network at a given point of time, traffic can be: <ul style="list-style-type: none"> <li>• Continuous.</li> <li>• Bursty.</li> <li>• Event driven.</li> <li>• Periodic.</li> <li>• All types.</li> </ul>
Communication range	RAN	Maximum distance between source and destination(s) of a radio transmission within which the application should achieve the specified reliability.
Infrastructure	INF	<ul style="list-style-type: none"> <li>• Limited: no infrastructure available or only macro cell coverage.</li> <li>• Medium density: Small number of small cells.</li> <li>• Highly available infrastructure: Big number of small cells available.</li> </ul>
Energy reduction	NRG	Reduction of the energy consumption of the overall system. The most common metric that is used to characterize this KPI is the reduction in the consumed Joules per delivered bit.
Cost	CST	Expenditure of resources, such as time, materials or labour, for the attainment of a certain HW or SW module. OPEX and CAPEX are important components

		of the overall costs.
Service creation time	SER	Time required to provision a service, measured since a new service deployment is requested until the overall orchestration system provides a response (a positive response implies the service has been actually provisioned).

## 5 Update of the plan for exploitation and dissemination of result

The communication, dissemination, and exploitation plan (CoDEP) presented in the proposal is periodically refined according to the evolution of the project and the activities considered of interest. The initial plan was presented in D6.1 [21] along with early achievements. D6.2 [22] presents the achievements during the initial period of the project as well as a refinement of the plan for the following period. It is not repeated here for brevity. The reader is referred to these documents.

## 6 Deviations from Annex 1

### 6.1 Tasks

T4.3 leadership has been transferred from MIRANTIS to UC3M, as approved during the PB meeting of January 17<sup>th</sup>, 2018.

### 6.2 Use of resources

As the first year of the project closes June 30<sup>th</sup>, 2018, the final information of resources (PMs) used during the first reporting period (M1-M13) will not be available before July 15<sup>th</sup>, 2018. That is why we include in this deliverable the PMs deviation used until the third quarterly of the project. The final version of the Periodic Report will be complete before the deadline (August 28<sup>th</sup> 2018).

## 7 References

- [1]. 5G-TRANSFORMER, D1.1, Report on vertical requirements and use cases, November 2017.
- [2]. 5G-TRANSFORMER, D1.2, 5G-TRANSFORMER initial system design, May 2018.
- [3]. 5G-TRANSFORMER, D2.1, Definition of the Mobile Transport and Computing Platform, March 2018.
- [4]. 5G-TRANSFORMER, D3.1, Definition of vertical service descriptors and SO NBI, March 2018.
- [5]. 5G-TRANSFORMER, D4.1, Definition of service orchestration and federation algorithms, service monitoring algorithms, March 2018.
- [6]. 5G-TRANSFORMER, D5.1, Definition of vertical testbeds and initial integration plans, May 2018.
- [7]. A. Ruete. "Communicating Horizon 2020 projects." Available at: <https://ec.europa.eu/easme/sites/easme-site/files/documents/6.Communication-AlexandraRuete.pdf>
- [8]. IPR Helpdesk. "IPR glossary". Available at: <https://www.iprhelpdesk.eu/glossary>
- [9]. ETSI GS NFV-MAN 001, "Network Functions Virtualisation (NFV); Management and Orchestration", v1.1.1, 2014.
- [10]. 5GEx deliverable D2.1, public version "Initial System Requirements and Architecture, Available at [https://drive.google.com/file/d/0B4O\\_JVjsvab9VXltUDJqMUR6d28/view](https://drive.google.com/file/d/0B4O_JVjsvab9VXltUDJqMUR6d28/view)
- [11]. Costa-Pérez, Xavier; García-Saavedra, Andrés; Li, Xi; Deiss, Thomas; Oliva, Antonio de la; Di Giglio, Andrea; Iovanna, Paola, and Mourad, Alain. 5G-Crosshaul: An SDN/NFV Integrated Fronthaul/Backhaul Transport Network Architecture. IEEE Wireless Communications, 24(1), pp. 38-45, February 2017.
- [12]. ETSI GS NFV-IFA 013, "Network Functions Virtualisation (NFV) Release 2; Management and Orchestration; Os-Ma-Nfvo reference point - Interface and Information Model Specification" v2.3.1, August 2017.
- [13]. ETSI GS NFV-IFA 005, "Network Function Virtualisation (NFV); Management and Orchestration; Or-Vi reference point - Interface and Information Model Specification", v2.1.1, 2016.
- [14]. ETSI GS NFV-IFA 006, "Network Function Virtualisation (NFV); Management and Orchestration; Vi-Vnfm reference point - Interface and Information Model Specification", v2.1.1, 2016.
- [15]. ETSI GS NFV-IFA 007, "Network Function Virtualisation (NFV); Management and Orchestration; Or-Vnfm reference point - Interface and Information Model Specification" v2.1.1, 2016.
- [16]. ETSI GS NFV-IFA 008, "Network Functions Virtualisation (NFV); Management and Orchestration; Ve-Vnfm reference point - Interface and Information Model Specification", v2.1.1, 2016.
- [17]. Topology and Orchestration Specification for Cloud Applications Version 1.0. 25 November 2013. OASIS Standard. [Online] <http://docs.oasis-open.org/tosca/TOSCA/v1.0/os/TOSCA-v1.0-os.html>
- [18]. SONATA D2.2. Architecture Design, [Online] <http://www.sonata-nfv.eu/content/d22-architecture-design-0>

- [19]. L. Cominardi, "Multi-domain federation: scope, challenges, and opportunities," Workshop in 3rd IEEE Conference on Network Softwarization, Bologna, Italy, July 2017.
- [20]. T. Swanson, "Consensus-as-a-service: A brief report on the emergence of permissioned, distributed ledger systems," Technical Report, Apr. 2015. [Online]. <http://www.ofnumbers.com/wp-content/uploads/2015/04/Permissioned-distributed-ledgers.pdf>. [Accessed: 06 Mar 2018]
- [21]. 5G-TRANSFORMER, D6.1, Initial Communication, Dissemination, and Exploitation Plan (CoDEP) draft including Standardization roadmap, November 2017.
- [22]. 5G-TRANSFORMER, D6.2, Communication, Dissemination, and Exploitation achievements of Y1 and plan for Y2, May 2018.
- [23]. ETSI GS NFV-IFA 028, "Network Functions Virtualisation (NFV) Release 3; Management and Orchestration; Report on architecture options to support multiple administrative domains", v3.1.1, January 2018.
- [24]. C. Casetti et.al., "Arbitration among Vertical Services", IEEE PIMRC Workshop, Bologna, Italy, accepted for publication, 2018.
- [25]. C. Casetti et.al., "Network Slices for Vertical Industries", IEEE WCNC Workshop: 1st Workshop on Control and management of Vertical slicing including the Edge and Fog Systems (COMPASS), Barcelona, Spain, Apr. 2018.
- [26]. 5G-PPP D2.6 Final report on programme progress and KPIs [https://5g-ppp.eu/wp-content/uploads/2017/10/Euro-5G-D2.6\\_Final-report-on-programme-progress-and-KPIs.pdf](https://5g-ppp.eu/wp-content/uploads/2017/10/Euro-5G-D2.6_Final-report-on-programme-progress-and-KPIs.pdf)
- [27]. Antonio de la Oliva et.al., "5G-TRANSFORMER: Slicing and Orchestrating Transport Networks for Industry Verticals", accepted by IEEE Communications Magazine, 2018.
- [28]. Xi Li et.al., "Service Orchestration and Federation for Verticals", 1st Workshop on Control and management of Vertical slicing including the Edge and Fog Systems (COMPASS), Barcelona, IEEE, 2018.
- [29]. P. Iovanna et.al., "5G Mobile Transport and Computing Platform for verticals", 1st Workshop on Control and management of Vertical slicing including the Edge and Fog Systems (COMPASS), Barcelona, IEEE, 2018.
- [30]. C. J. Bernardos, A. De La Oliva, F. Giust, J.C. Zuniga, A. Mourad, "Proxy Mobile IPv6 extensions for Distributed Mobility Management", September 2018, IETF draft (work-in-progress), draft-bernardos-dmm-pmipv6-dlif-01.
- [31]. C. J. Bernardos, et al., "Multi-domain Network Virtualization", September 2018, IETF draft (work-in-progress), draft-bernardos-nfvrg-multidomain-04.
- [32]. L. Geng, et al., "COMS Architecture", September 2018, IETF draft (work-in-progress), draft-geng-coms-architecture-02.
- [33]. L. Geng, et al., "Problem Statement of Common Operation and Management of Network Slicing", September 2018, IETF draft (work-in-progress), draft-geng-coms-problem-statement-03.